

## Owner's Manual 60 Hz Air-Cooled Generators

7.5 kW PowerPact™

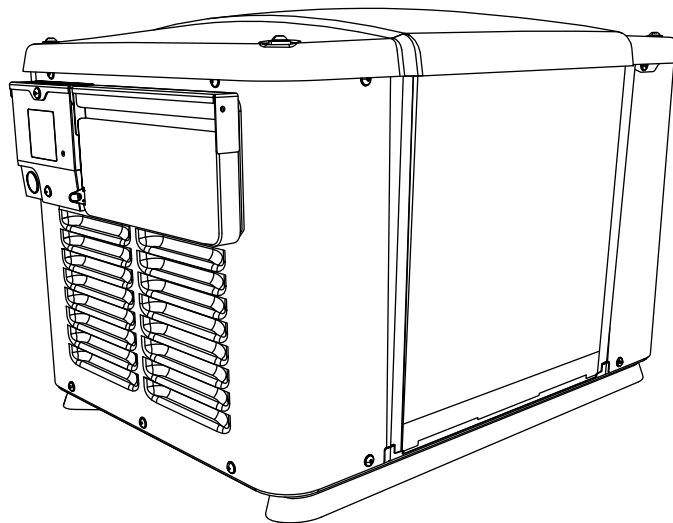

### **WARNING**

Loss of life. This product is not intended to be used in a critical life support application. Failure to adhere to this warning could result in death or serious injury. (000209b)

Register your Generac product at:  
[WWW.GENERAC.COM](http://WWW.GENERAC.COM)  
1-888-GENERAC  
(888-436-3722)

Para español , visita: <http://www.generac.com/service-support/product-support-lookup>

Pour le français, visiter : <http://www.generac.com/service-support/product-support-lookup>

**SAVE THIS MANUAL FOR FUTURE REFERENCE**

**Use this page to record important information about this generator set.**

Model:	
Serial:	
Prod Date Week:	
Volts:	
LPV Amps:	
NG Amps:	
Hz:	
Phase:	
Controller P/N:	

Record the information found on your unit data label on this page. The unit has a label plate affixed to the inside partition, above the battery access panel as shown in **Figure 2-1**. For directions on how to open the top lid and remove the front panel, see the Owner's Manual.

Always supply the complete model and serial numbers of the unit when contacting an Independent Authorized Service Dealer (IASD) about parts and service.

**Operation and Maintenance:** Correct maintenance and care of the unit ensures a minimum number of problems, and keeps operating expenses at a minimum. It is the operator's responsibility to perform all safety inspections, to verify all maintenance for safe operation is performed promptly, and to have the equipment inspected periodically by an IASD. Normal maintenance, service, and replacement of parts are the responsibility of the owner/operator and are not considered defects in materials or workmanship within the terms of the warranty. Individual operating habits and usage may contribute to the need for additional maintenance or service.

When the generator requires servicing or repairs, Generac recommends contacting an IASD for assistance. Authorized service technicians are factory-trained and are capable of handling all service needs. To locate the nearest IASD, please visit the dealer locator at: [www.generac.com/Dealer-Locator](http://www.generac.com/Dealer-Locator).

 <b>WARNING</b> <b>CANCER AND REPRODUCTIVE HARM</b> <a href="http://www.P65Warnings.ca.gov">www.P65Warnings.ca.gov</a> (000393a)
--

# Table of Contents

## **Section 1: Safety Information**

<b>Introduction</b> .....	1
Read This Manual Thoroughly .....	1
<b>Safety Rules</b> .....	1
How to Obtain Service .....	1
<b>General Hazards</b> .....	2
<b>Exhaust Hazards</b> .....	3
<b>Electrical Hazards</b> .....	3
<b>Fire Hazards</b> .....	3
<b>Explosion Hazards</b> .....	4
<b>Battery Hazards</b> .....	4

## **Section 2: General Information**

<b>Generator Features and Components</b> .....	7
<b>Specifications</b> .....	8
Generator .....	8
Engine .....	8
<b>Data Decals</b> .....	9
<b>Protection Systems</b> .....	10
<b>Emissions</b> .....	10
<b>Fuel Requirements</b> .....	10
<b>Battery Requirements</b> .....	10
<b>Battery Charger</b> .....	10
<b>Engine Oil Requirements</b> .....	10
<b>Replacement Parts</b> .....	11
<b>Accessories</b> .....	11

## **Section 3: Operation**

<b>Site Prep Verification</b> .....	13
<b>Controller Lid</b> .....	13
<b>Main Line Circuit Breaker (Generator Disconnect)</b> .....	13
<b>Control Panel</b> .....	14
<b>Using the AUTO/OFF/MANUAL Interface</b> .....	14
<b>Using the LED Interface</b> .....	14
<b>Operating Modes</b> .....	15
<b>Alarm Response Procedures</b> .....	15
Clearing an Alarm/Warning Condition .....	15
<b>Setting the Exercise Timer</b> .....	15
<b>Battery Charger</b> .....	16
<b>Manual Transfer Operation</b> .....	16
Transfer to Generator Power Source .....	16
Transfer Back to Utility Power Source .....	16

<b>Automatic Transfer Operation</b> .....	16
<b>Automatic Sequence of Operation</b> .....	16
Utility Failure .....	16
Cranking .....	17
Cold Smart Start .....	17
Load Transfer .....	17

<b>Shutting Generator Down While Under Load or During a Utility Outage</b> .....	17
<b>Generator Emergency Shutdown Switch</b> .....	17

## **Section 4: Maintenance**

<b>Maintenance</b> .....	19
<b>Performing Scheduled Maintenance</b> .....	19
<b>Clearing a Maintenance Due Condition</b> .....	19
<b>Service Schedule</b> .....	20
<b>Maintenance Log</b> .....	21
<b>Checking Engine Oil Level</b> .....	22
Engine Oil Recommendations .....	22
<b>Changing the Oil</b> .....	23
<b>Changing the Engine Air Cleaner</b> .....	23
<b>Spark Plug</b> .....	23
<b>Valve Clearance Adjustment</b> .....	24
Inspecting Valve Clearance .....	24
Adjusting Valve Clearance .....	24
<b>Battery Maintenance</b> .....	25
<b>Attention After Submersion</b> .....	25
<b>Corrosion Protection</b> .....	25
<b>Remove From, and Return To Service Procedure</b> ..	26
Remove From Service .....	26
Return to Service .....	26

## **Section 5: Troubleshooting**

<b>Generator Troubleshooting</b> .....	27
<b>Quick Reference Guide</b> .....	29

**This page intentionally left blank.**

# Section 1: Safety Information

## Introduction

Thank you for purchasing this compact, high performance, air-cooled, engine-driven generator. It is designed to automatically supply electrical power to operate critical loads during a utility power failure.

This unit is factory installed in an all-weather, metal enclosure intended exclusively for outdoor installation. This generator will operate using either vapor withdrawn liquid propane (LP) or natural gas (NG).

**NOTE:** When sized correctly, this generator is suitable for supplying typical residential loads such as induction motors (sump pumps, refrigerators, air conditioners, furnaces, etc.), electronic components (computer, monitor, TV, etc.), lighting loads and microwaves.

The information in this manual is accurate based on products produced at the time of publication. The manufacturer reserves the right to make technical updates, corrections, and product revisions at any time without notice.

## Read This Manual Thoroughly



Consult Manual. Read and understand manual completely before using product. Failure to completely understand manual and product could result in death or serious injury. (000100a)

If any section of this manual is not understood, contact the nearest Independent Authorized Service Dealer (IASD) or Generac Customer Service at 1-888-436-3722 (1-888-GENERAC), or visit [www.generac.com](http://www.generac.com) for starting, operating, and servicing procedures. The owner is responsible for correct maintenance and safe use of the unit.

This manual must be used in conjunction with all other supporting product documentation supplied with the product.

SAVE THESE INSTRUCTIONS for future reference. This manual contains important instructions that must be followed during placement, operation, and maintenance of the unit and its components. Always supply this manual to any individual that will use this unit, and instruct them on how to correctly start, operate, and stop the unit in case of emergency.

## Safety Rules

The manufacturer cannot anticipate every possible circumstance that might involve a hazard. The alerts in this manual, and on tags and decals affixed to the unit, are not all inclusive. If using a procedure, work method, or

operating technique that the manufacturer does not specifically recommend, verify that it is safe for others and does not render the equipment unsafe.

Throughout this publication, and on tags and decals affixed to the unit, DANGER, WARNING, CAUTION, and NOTE blocks are used to alert personnel to special instructions about a particular operation that may be hazardous if performed incorrectly or carelessly. Observe them carefully. Alert definitions are as follows:



Indicates a hazardous situation which, if not avoided, will result in death or serious injury.

(000001)



Indicates a hazardous situation which, if not avoided, could result in death or serious injury.

(000002)



Indicates a hazardous situation which, if not avoided, could result in minor or moderate injury.

(000003)

**NOTE:** Notes contain additional information important to a procedure and will be found within the regular text of this manual.

These safety alerts cannot eliminate the hazards that they indicate. Common sense and strict compliance with the special instructions while performing the action or service are essential to preventing accidents.

## How to Obtain Service

When the unit requires servicing or repairs, contact Generac Customer Service at 1-888-GENERAC (1-888-436-3722) or visit [www.generac.com](http://www.generac.com) for assistance.

When contacting Generac Customer Service about parts and service, always supply the complete model and serial number of the unit as given on its data decal located on the unit. Record the model and serial numbers in the spaces provided on the front cover of this manual.

## General Hazards

### **⚠ DANGER**

Loss of life. Property damage. Installation must always comply with applicable codes, standards, laws and regulations. Failure to do so will result in death or serious injury. (000190)

### **⚠ DANGER**

Automatic start-up. Disconnect utility power and render unit inoperable before working on unit. Failure to do so will result in death or serious injury. (000191)



### **⚠ WARNING**

Loss of life. This product is not intended to be used in a critical life support application. Failure to adhere to this warning could result in death or serious injury. (000209b)

### **⚠ WARNING**

Equipment damage. This unit is not intended for use as a prime power source. It is intended for use as an intermediate power supply in the event of temporary power outage only. Doing so could result in death, serious injury, and equipment damage. (000247a)

### **⚠ WARNING**

Accidental Start-up. Disconnect the negative battery cable, then the positive battery cable when working on unit. Failure to do so could result in death or serious injury. (000130)

### **⚠ WARNING**

Equipment damage. Only qualified service personnel may install, operate, and maintain this equipment. Failure to follow proper installation requirements could result in death, serious injury, and equipment or property damage. (000182a)



### **⚠ WARNING**

Electrocution. Potentially lethal voltages are generated by this equipment. Render the equipment safe before attempting repairs or maintenance. Failure to do so could result in death or serious injury. (000187)

### **⚠ WARNING**

Electric shock. Only a trained and licensed electrician should perform wiring and connections to unit. Failure to follow proper installation requirements could result in death, serious injury, and equipment or property damage. (000155a)



### **⚠ WARNING**

Moving Parts. Do not wear jewelry when starting or operating this product. Wearing jewelry while starting or operating this product could result in death or serious injury. (000115)



### **⚠ WARNING**

Moving Parts. Keep clothing, hair, and appendages away from moving parts. Failure to do so could result in death or serious injury. (000111)



### **⚠ WARNING**

Hot Surfaces. When operating machine, do not touch hot surfaces. Keep machine away from combustibles during use. Hot surfaces could result in severe burns or fire. (000108)

### **⚠ WARNING**

Equipment and property damage. Do not alter construction of, installation, or block ventilation for generator. Failure to do so could result in unsafe operation or damage to the generator. (000146)

### **⚠ WARNING**

Risk of injury. Do not operate or service this machine if not fully alert. Fatigue can impair the ability to operate or service this equipment and could result in death or serious injury. (000215a)

### **⚠ WARNING**

Environmental Hazard. Always recycle batteries at an official recycling center in accordance with all local laws and regulations. Failure to do so could result in environmental damage, death, or serious injury. (000228)

### **⚠ WARNING**

Injury and equipment damage. Do not use generator as a step. Doing so could result in falling, damaged parts, unsafe equipment operation, and could result in death or serious injury. (000216)

- Inspect generator regularly, and contact the nearest IASD for parts needing repair or replacement.

## Exhaust Hazards



### ⚠ DANGER

Asphyxiation. Running engines produce carbon monoxide, a colorless, odorless, poisonous gas. Carbon monoxide, if not avoided, will result in death or serious injury.

(000103)



### ⚠ WARNING

Asphyxiation. Always use a battery operated carbon monoxide alarm indoors and installed according to the manufacturer's instructions. Failure to do so could result in death or serious injury.

(000178a)

### ⚠ WARNING

Equipment and property damage. Do not alter construction of, installation, or block ventilation for generator. Failure to do so could result in unsafe operation or damage to the generator.

(000146)



### ⚠ WARNING

Fire risk. Fuel and vapors are extremely flammable. Do not operate indoors. Doing so could result in death, serious injury, or property or equipment damage.

(000281)

## Electrical Hazards



### ⚠ DANGER

Electrocution. Contact with bare wires, terminals, and connections while generator is running will result in death or serious injury.

(000144)



### ⚠ DANGER

Electrocution. Never connect this unit to the electrical system of any building unless a licensed electrician has installed an approved transfer switch. Failure to do so will result in death or serious injury.

(000150)

### ⚠ DANGER

Electrical backfeed. Use only approved switchgear to isolate generator from the normal power source. Failure to do so will result in death, serious injury, and equipment damage.

(000237)



### ⚠ DANGER

Electrocution. Verify electrical system is properly grounded before applying power. Failure to do so will result in death or serious injury.

(000152)



### ⚠ DANGER

Electrocution. Do not wear jewelry while working on this equipment. Doing so will result in death or serious injury.

(000188)



### ⚠ DANGER

Electrocution. Water contact with a power source, if not avoided, will result in death or serious injury.

(000104)



### ⚠ DANGER

Electrocution. In the event of electrical accident, immediately shut power OFF. Use non-conductive implements to free victim from live conductor. Apply first aid and get medical help. Failure to do so will result in death or serious injury.

(000145)

## Fire Hazards



### ⚠ WARNING

Fire hazard. Do not obstruct cooling and ventilating airflow around the generator. Inadequate ventilation could result in fire hazard, possible equipment damage, death or serious injury.

(000217)



### ⚠ WARNING

Fire and explosion. Installation must comply with all local, state, and national electrical building codes. Noncompliance could result in unsafe operation, equipment damage, death, or serious injury.

(000218)



### ⚠ WARNING

Fire hazard. Use only fully-charged fire extinguishers rated "ABC" by the NFPA. Discharged or improperly rated fire extinguishers will not extinguish electrical fires in automatic standby generators.

(000219)



**⚠ WARNING**

Consult Manual. Read and understand manual completely before using product. Failure to completely understand manual and product could result in death or serious injury. (000100a)



**⚠ WARNING**

Electrocution. Refer to local codes and standards for safety equipment required when working with a live electrical system. Failure to use required safety equipment could result in death or serious injury. (000257)



**⚠ WARNING**

Risk of Fire. Unit must be positioned in a manner that prevents combustible material accumulation underneath. Failure to do so could result in death or serious injury. (000147)

Comply with regulations the local agency for workplace health and safety has established. Also, verify that the generator is installed in accordance with the manufacturer's instructions and recommendations. Following proper installation, do nothing that might alter a safe installation and render the unit in noncompliance with the aforementioned codes, standards, laws, and regulations.

## Explosion Hazards



**⚠ DANGER**

Explosion and fire. Fuel and vapors are extremely flammable and explosive. No leakage of fuel is permitted. Keep fire and spark away. Failure to do so will result in death or serious injury. (000192)

**⚠ DANGER**

Explosion and fire. Connection of fuel source must be completed by a qualified professional technician or contractor. Incorrect installation of this unit will result in death, serious injury, and property and equipment damage. (000151a)



**⚠ DANGER**

Risk of fire. Allow fuel spills to completely dry before starting engine. Failure to do so will result in death or serious injury. (000174)



**⚠ WARNING**

Risk of Fire. Hot surfaces could ignite combustibles, resulting in fire. Fire could result in death or serious injury. (000110)

## Battery Hazards



**⚠ DANGER**

Electrocution. Do not wear jewelry while working on this equipment. Doing so will result in death or serious injury. (000188)



**⚠ WARNING**

Explosion. Do not dispose of batteries in a fire. Batteries are explosive. Electrolyte solution can cause burns and blindness. If electrolyte contacts skin or eyes, flush with water and seek immediate medical attention. (000162)



**⚠ WARNING**

Explosion. Batteries emit explosive gases while charging. Keep fire and spark away. Wear protective gear when working with batteries. Failure to do so could result in death or serious injury. (000137a)



**⚠ WARNING**

Electrical shock. Disconnect battery ground terminal before working on battery or battery wires. Failure to do so could result in death or serious injury. (000164)



**⚠ WARNING**

Risk of burns. Batteries contain sulfuric acid and can cause severe chemical burns. Wear protective gear when working with batteries. Failure to do so could result in death or serious injury. (000138a)



**⚠ WARNING**

Risk of burn. Do not open or mutilate batteries. Batteries contain electrolyte solution which can cause burns and blindness. If electrolyte contacts skin or eyes, flush with water and seek immediate medical attention. (000163a)



**⚠WARNING**

Environmental Hazard. Always recycle batteries at an official recycling center in accordance with all local laws and regulations. Failure to do so could result in environmental damage, death, or serious injury. (000228)

---

Always recycle batteries in accordance with local laws and regulations. Contact your local solid waste collection site or recycling facility to obtain information on local recycling processes. For more information on battery recycling, visit the Battery Council International website at: <http://batteryCouncil.org>.

**This page intentionally left blank.**

## Section 2: General Information

### Generator Features and Components

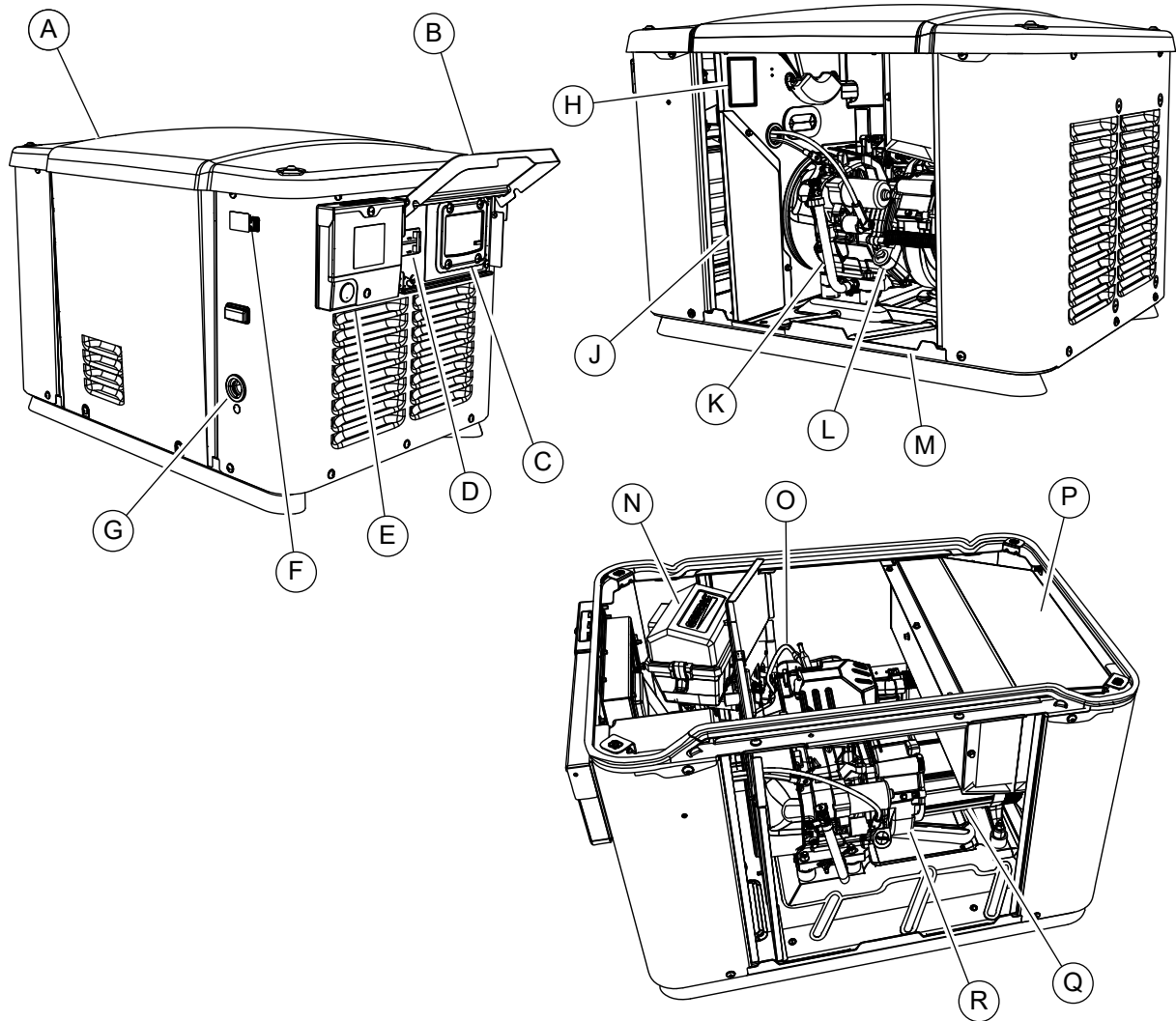

005568

**Figure 2-1. Features and Components**

A	Enclosure lid	G	Fuel connection hole	N	Air box
B	Controller lid	H	Data label	O	Spark plug
C	Control panel	J	Battery access panel	P	Exhaust enclosure
D	Main line circuit breaker	K	Oil drain hose	Q	Alternator
E	Customer connection box	L	Oil fill / dipstick	R	Starter motor
F	Generator emergency shutdown switch	M	Front panel (not shown)		

## Specifications

### Generator

Model	7.5 kW
Rated voltage	240
Rated maximum load current (amps) at rated volts (LP)*	31.25
Main line circuit breaker (generator disconnect)	35 Amp
Phase	1
Rated AC frequency	60 Hz
Battery requirement	Group U1, 12 Volts and 300 CCA Minimum (see <a href="#">Replacement Parts</a> )
Enclosure	Galvanneal steel
Unit weight	280 lbs (127.3 kg)
Normal operating range	This unit is tested in accordance to UL 2200 standards with an operating temperature of -20 °F (-29 °C) to 122 °F (50 °C). For areas where temperatures fall below 32 °F (0 °C) a cold weather kit is recommended. When operated above 77 °F (25 °C) there may be a decrease in engine power. (Please reference the engine specifications section.)

These generators are rated in accordance with UL 2200, Safety Standard for Stationary Engine Generator Assemblies, and CSA-C22.2 No. 100-04 Standard for Motors and Generators.

\* Natural Gas ratings will depend on specific fuel joules/Btu content. Typical derates are between 10-20% off the LP gas rating.

\*\* Circuits to be moved must be protected by same size breaker. For example, a 15 amp circuit in the main panel must be a 15 amp circuit in the transfer switch.

### Engine



Model	7.5 kW
Engine type	GA-420
Number of cylinders	1
Displacement	25.6 in <sup>3</sup> (420 cc)
Cylinder block	Aluminum w/ cast iron sleeve
Recommended spark plug	See <a href="#">Replacement Parts</a>
Spark plug gap	0.030 in (0.76 mm)
Valve clearance	0.002 - 0.004 in (0.05 - 0.1 mm)
Starter	12 VDC
Oil capacity	Approx. 1.2 qt (1.1 L)
Recommended air filter	See <a href="#">Replacement Parts</a>

Engine power is subject to and limited by such factors as fuel Btu/joules, ambient temperature and altitude. Engine power decreases about 3.5 percent for each 1000 feet (304.8 meters) above sea level, and also will decrease about 1 percent for each 10 °F (6 °C) above 60 °F (15 °C) ambient temperature.

A detailed specification sheet for a particular generator is available from an IASD.

## Data Decals

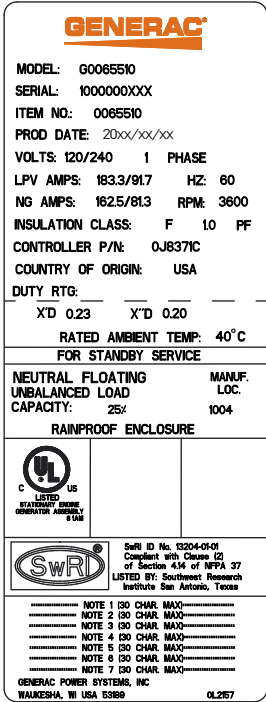
Two decals on the generator provide information about the unit itself and the required fuel inlet pressure for correct operation.

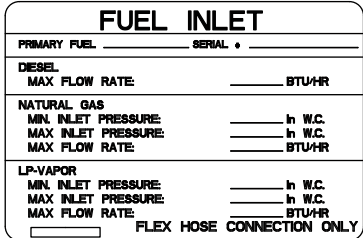
 <p><b>GENERAC</b></p> <p>MODEL: G0065510          SERIAL: 1000000XXX          ITEM NO: 0065510          PROD DATE: 20xx/xx/xx          VOLTS: 120/240 1 PHASE          LPV AMPS: 183.3/91.7 HZ: 60          NG AMPS: 162.5/81.3 RPM: 3600          INSULATION CLASS: F 10 PF          CONTROLLER P/N: OJ837C          COUNTRY OF ORIGIN: USA          DUTY RTG:          X'D 0.23 X'D 0.20          RATED AMBIENT TEMP: 40°C          FOR STANDBY SERVICE</p> <p>NEUTRAL FLOATING UNBALANCED LOAD CAPACITY: 25%          MANUF. LOC. 1004</p> <p>RAINPROOF ENCLOSURE</p> <p> LISTED          STATISTICAL ENGINE          GENERATOR ASSEMBLY          &amp; TAP</p> <p> SwRI ID No. 13204-04-01          Compliant with Clause G2          of Section 4.14 of NFPA 37          LISTED BY: Southwest Research          Institute San Antonio, Texas</p> <p>NOTE 1 ISO CHAR. MAX          NOTE 2 ISO CHAR. MAX          NOTE 3 ISO CHAR. MAX          NOTE 4 ISO CHAR. MAX          NOTE 5 ISO CHAR. MAX          NOTE 6 ISO CHAR. MAX          NOTE 7 ISO CHAR. MAX</p> <p>GENERAC POWER SYSTEMS, INC.          WAUKESHA, WI USA 53080 0L267</p>	<p><b>Model Data Decal</b></p> <p>Includes important information about the unit including:</p> <ul style="list-style-type: none"> <li>• model number</li> <li>• serial number</li> <li>• production date</li> <li>• voltage</li> <li>• frequency</li> <li>• amps</li> <li>• country of origin</li> <li>• rated ambient temperature.</li> </ul> <p>The model data decal also displays certification symbols by Underwriter's Laboratory (UL) and the Southwest Research Institute (SwRI).</p>
 <p><b>FUEL INLET</b></p> <p>PRIMARY FUEL _____ SERIAL # _____</p> <p><b>DIESEL</b>          MAX FLOW RATE: _____ BTU/HR</p> <p><b>NATURAL GAS</b>          MIN. INLET PRESSURE: _____ in W.C.          MAX INLET PRESSURE: _____ in W.C.          MAX FLOW RATE: _____ BTU/HR</p> <p><b>LP-VAPOR</b>          MIN. INLET PRESSURE: _____ in W.C.          MAX INLET PRESSURE: _____ in W.C.          MAX FLOW RATE: _____ BTU/HR</p> <p>_____ FLEX HOSE CONNECTION ONLY</p>	<p><b>Fuel Inlet Pressure</b></p> <p>Displays the unit serial number, along with the minimum and maximum inlet pressures for natural gas (NG) and liquid propane (LP) supply. Space is provided for the installer to enter maximum flow rates based on installed pipe sizes and lengths.</p>

## Protection Systems

The generator may have to run for long periods of time with no operator present to monitor the engine/generator conditions. Therefore, the generator is equipped with a number of systems to automatically shut down the unit to protect it against potentially damaging conditions. Some of these systems are as follows:

- Low Oil Level Sensor
- High Temperature Sensor
- Overcrank Detection
- Overspeed Detection
- RPM Sensor
- Underspeed Detection
- Charger Problem Detection
- Battery Problem Detection
- Fuse Problem Detection (missing or failed)
- Wiring Error Detection

The control panel contains LEDs which alert the operator when a fault condition occurs. The above list is not all inclusive. For more information about alarms and control panel operation, see [Operation](#).

## Emissions

The United States Environmental Protection Agency (US EPA) (and California Air Resources Board (CARB), for engines/equipment certified to California standards) requires that this engine/equipment complies with exhaust and evaporative emissions standards. Locate the emissions compliance decal on the engine to determine applicable standards. For emissions warranty information, please reference the included emissions warranty. It is important to follow the maintenance specifications in the manual to ensure that the engine complies with the applicable emissions standards for the duration of the product's life.

This generator is certified to operate on Liquid Propane Vapor fuel or pipeline Natural Gas.

The Emission Control System code is EM (Engine Modification). The Emission Control System on this generator consists of the following:

System	Components
Air induction	- Airbox assembly - Air cleaner
Fuel metering	- Carburetor / mixer assembly - Fuel regulator - Fuel jet
Ignition	- Spark plug - Ignition module
Exhaust	- Exhaust manifold - Muffler - Muffler system

## Fuel Requirements



**DANGER**

Explosion and Fire. Fuel and vapors are extremely flammable and explosive. Add fuel in a well ventilated area. Keep fire and spark away. Failure to do so will result in death or serious injury. (000105)

The engine has been fitted with a dual fuel carburetion system. The unit will run on natural gas or LP gas (vapor), but it has been factory set to run on natural gas. The fuel system will be configured for the available fuel source during installation.

Recommended fuels should have a BTU content of at least 1000 BTUs per cubic foot (37.26 megajoules per cubic meter) for natural gas, or at least 2500 BTUs per cubic foot (93.15 megajoules per cubic meter) for LP gas (vapor).

**NOTE:** If converting to LP gas from NG, consult with your local LP fuel provider to correctly size the generator fuel tank. See Installation Manual for complete procedures and details.

## Battery Requirements

Group U1, 12V, minimum 300 CCA.

For correct battery maintenance procedures, see [Maintenance](#).

## Battery Charger

The battery charger is integrated into the control panel module in all models. It operates as a Smart Charger which ensures output charging levels are safe and continuously optimized to promote maximum battery life.

## Engine Oil Requirements

For correct oil viscosity, see chart in [Figure 4-2](#).

## Replacement Parts

Description	7.5 kW
U1 battery	0J5584
Spark plug	0L3059
Air filter	0E9371A
Control panel fuse (7.5 amp)	0D7178T
Transfer switch fuses	See transfer switch owner's manual for part number

## Accessories

Performance enhancing accessories are available for air-cooled generators.

Accessory	Description
Cold Weather Kit G006808-1	Recommended in areas where temperatures fall below 32 °F (0 °C).
Scheduled Maintenance Kit G006806-0	Includes all pieces necessary to perform maintenance on the generator, along with oil recommendations (oil not included).
Touch-Up Paint Kit G005703-0	If the generator enclosure is scratched or damaged, it is important to touch-up the paint to protect from future corrosion. The touch-up paint kit includes the necessary paint to correctly maintain or touch-up a generator enclosure.
Wireless Local Monitor G006664-0	Completely wireless and battery powered, the Wireless Local Monitor provides users with instant status without ever leaving the house. Status lights (red, yellow and green) alert owners when the generator needs attention. Magnetic backing permits refrigerator mounting and gives a 600 foot (183 m) line of sight communication.
LTE LP Fuel Level Monitor G007009-0	The LTE enabled LP fuel level monitor provides constant monitoring of the connected LP fuel tank. Monitoring the LP fuel tank's fuel level is an important step in making sure your generator is ready to run during an unexpected power failure. Status alerts are available through a free application to notify when your LP tank is in need of a refill.
Extended Warranty Coverage (Available only in U.S. and Canada)	Extend generator warranty coverage by purchasing extended warranty coverage. Covers both parts and labor. Extended coverage can be purchased within 12 months of the end-users purchase date. This extended coverage is applicable to registered units and end-user proof of purchase must be available upon request. Available for Generac®, Guardian® and PowerPact® products. Not available for Corepower™ and EcoGen™ products or all international purchases.

**NOTE:** Contact an IASD or visit [www.generac.com](http://www.generac.com) for additional information on replacement parts, accessories, and extended warranties.

**This page intentionally left blank.**



## Section 3: Operation

### Site Prep Verification

#### **DANGER**

Automatic start-up. Disconnect utility power and render unit inoperable before working on unit. Failure to do so will result in death or serious injury.

(000191)



#### **WARNING**

Risk of fire. Keep air inlet and exhaust areas free from leaves, grass, snow and other debris. Failure to do so could result in death, serious injury, property, and equipment damage.

(000251)

#### **WARNING**

Equipment damage. Only qualified service personnel may install, operate, and maintain this equipment. Failure to follow proper installation requirements could result in death, serious injury, and equipment or property damage.

(000182a)

Generator must be installed to allow unimpeded airflow. Verify all shrubs or tall grasses have been removed within 3 ft (0.91 m) of the intake and discharge louvers on the sides of the enclosure. Install generator on high ground where water levels will not rise and endanger it. This unit must not operate in or be subjected to standing water. Verify all potential sources such as water sprinklers, roof run-off, rain gutter down spouts, and sump pump discharges are directed away from unit.

### Controller Lid

Proceed as follows to open or close the controller lid:

1. See [Figure 3-1](#). Lift lid from bottom to open (A). Lid will lock in place when raised.

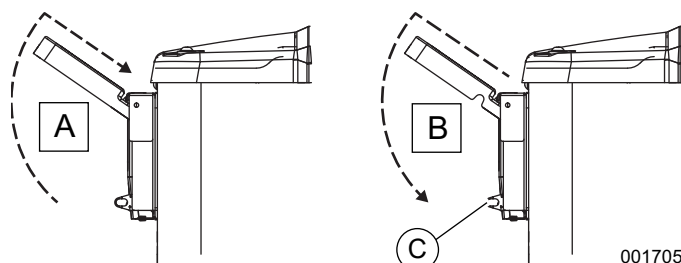

**Figure 3-1. Open and Close Controller Lid**

2. Pull raised lid up and out slightly to unlock (B), then lower to close.

**NOTE:** Local codes may require this compartment to be locked. A hasp is provided so the owner/operator can secure the compartment with a padlock (C). Check local codes for side compartment locking requirements.

**NOTE:** All appropriate panels must be in place during any operation of the generator. This includes operation by a servicing technician while conducting troubleshooting procedures.

### Main Line Circuit Breaker (Generator Disconnect)

See [Figure 3-2](#). The main line circuit breaker (MLCB) (generator disconnect) (A) is located under controller lid. Open controller lid to access circuit breaker.

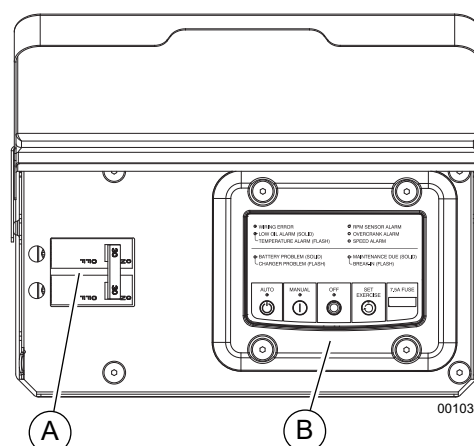

**Figure 3-2. Control Panel and Circuit Breaker**

## Control Panel

See [Figure 3-2](#). The control panel (B) is located under the controller lid. Open controller lid to access the control panel.

See [Figure 3-3](#). The AUTO/OFF/MANUAL interface located on the control panel has the following features:

- Alarm LEDs (A)
- Warning LEDs (B)
- Operation mode buttons and LEDs (C)

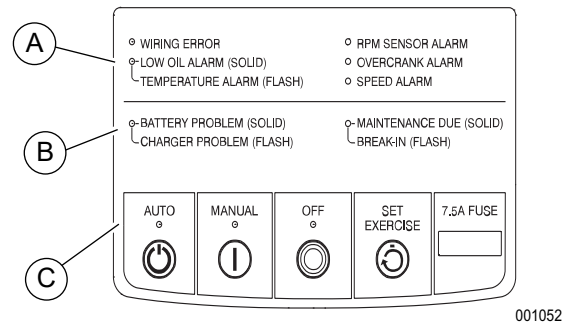

Figure 3-3. Generator Control Panel and LEDs

## Using the AUTO/OFF/MANUAL Interface

Button	Description of Operation
<b>AUTO (GREEN)</b>	Activates fully automatic system operation. It also allows the unit to automatically start and exercise the engine every seven days with the setting of the exercise timer (see <a href="#">Setting the Exercise Timer</a> ).
<b>MANUAL (BLUE)</b>	Cranks and starts generator. Transfer to standby power will not occur unless there is a utility failure.
<b>OFF (RED)</b>	Shuts down engine and also prevents automatic operation of the unit.
<b>SET EXERCISE (GREY)</b>	Establishes generator exercise time. Hold the button for 3 seconds at the new exercise time desired. <b>NOTE:</b> Exercise time can only be set at the time you wish exercise to actually take place.

**NOTE:** Transfer to generator power will cause either the AUTO, MANUAL, or OFF button to flash, depending on which mode the generator is in when utility is lost.

## Using the LED Interface

User interface includes seven LEDs to indicate generator alarms, warnings, and maintenance actions due. See [Figure 3-3](#) and the following table for details on each indication.

The user interface also includes 3-mode LEDs to indicate the current generator mode setting (AUTO, MANUAL, or OFF). The active LED is also used to indicate whether

the utility voltage is present. The active LED will be solid when utility is available. It will flash to indicate the loss of utility power. For example; when generator is in AUTO and utility is present, green AUTO LED will be solid ON. When generator is in AUTO and utility is lost, AUTO LED will flash.

LED Alarm	Description (LED Flashing)	Description (LED Solid)
Temperature Alarm (Flashing) Low Oil Level Alarm (Solid) *	Temperature levels are excessive Emergency shutdown switch is OPEN (O).	— Engine oil level is insufficient
Charger Warning (Flashing) Battery Problem Warning (Solid) *	Charging problem exists —	— Battery problem exists
RPM Sensor Alarm	—	RPM sensor problem exists
Overcrank Alarm	—	Overcranking condition exists
Speed Alarm *	Overspeed condition exists	Underspeed condition exists
Break-in Maintenance Due (Flashing) Regular Maintenance Due (Solid) *	20 hour break-in maintenance due —	— 1 year / 100 hour maintenance due

\* These LEDs are shared with multiple alarm conditions. Solid light indicates one alarm. Flashing light indicates the other alarm condition.

## Operating Modes

Mode	Description
MANUAL	<ul style="list-style-type: none"> <li>Will not transfer to generator if utility is present.</li> <li>Transfers to generator if utility fails (below 65% of nominal for 10 consecutive seconds).</li> <li>Transfers back when utility returns for 15 consecutive seconds. Engine will continue to run until removed from MANUAL mode.</li> </ul>
AUTO	<ul style="list-style-type: none"> <li>Starts and runs if utility fails (below 65% of nominal for 5 consecutive seconds).</li> <li>Starts a 6 second engine warm-up timer (or 30 seconds; see <b>Cold Smart Start</b>). <ul style="list-style-type: none"> <li>–Will not transfer if utility subsequently returns.</li> <li>–Will transfer to generator if utility is not present.</li> </ul> </li> <li>Transfers back to utility once utility returns (above 80% of nominal) for 15 seconds.</li> <li>Will not transfer back to utility unless utility returns. Generator will shut down if OFF button is pressed or a shutdown alarm is present.</li> <li>Once utility power is returned, generator will shut down after one minute cool-down time.</li> </ul>
EXERCISE	<ul style="list-style-type: none"> <li>Will not exercise if generator is already running in either AUTO or MANUAL mode.</li> <li>During exercise, control panel will only transfer if utility fails during exercise for six seconds (or 30 seconds; see <b>Cold Smart Start</b>) and will operate as normal in AUTO mode.</li> </ul>

## Alarm Response Procedures

The generator is protected by a series of sensors that will detect an Alarm/Warning condition and alert the owner/operator of the condition via the control panel display. Generator will shut down when certain alarm conditions are detected.

### Clearing an Alarm/Warning Condition

Press OFF button to clear an alarm or warning condition from control panel. Press OFF button again to turn off flashing or solid indicator LED.

LED Condition	Action	2nd Action	3rd Action
Clear Alarm / Warning or Maintenance LED Alarm(s)	Press OFF	Press OFF again	—
Clear Maintenance LED when Alarm or Warning LED is also present	Press OFF	Press OFF again	Press OFF 3rd time

**NOTE:** Clearing a code will not correct the problem. It will simply turn off the LED indicating a problem occurred. The problem indicated must be diagnosed and corrected to prevent a re-occurring alarm condition.

**NOTE:** Removing or failure of the 7.5 amp ATO<sup>®</sup> fuse will turn off all the panel LEDs. Replacement of the fuse will initiate the LED self test.

## Setting the Exercise Timer

This generator is equipped with an exercise timer. Generator will start and exercise every seven days, on the day of the week and at the time of day this procedure was initiated. During this exercise period, the unit runs for approximately 12 minutes and then shuts down. Transfer of loads to the generator output does not occur during the exercise cycle unless utility power is lost.

1. Place generator in AUTO.
2. Hold SET EXERCISE button for 3 seconds. Generator will start, run an exercise cycle, and verify the setting.
3. Exercise time is now established. Generator will exercise each week at this time.

To CHANGE the exercise time once it has been set, hold the SET EXERCISE button on the generator for three (3) seconds at the new desired exercise time to take place. The exercise timer does not correct for daylight saving time.

**NOTE:** Exerciser will only work in AUTO and will default to exercise weekly at the time the control panel was last powered ON unless this procedure is performed. The exercise function will need to be reset every time the 12 volt battery and T1 power to the generator are disconnected and then reconnected, or when the fuse is removed and T1 power is removed from the generator, or both.

**NOTE:** If the unit is equipped with Mobile Link<sup>®</sup>, exercise time can be remotely set for any desired day or time.

## Battery Charger

**NOTE:** The battery charger is integrated into the control panel.

The battery charger operates as a Smart Charger which:

- verifies output is continually optimized to promote maximum battery life.
- verifies charging levels are safe.

**NOTE:** Battery Problem LED is illuminated when battery needs service.

## Manual Transfer Operation



**⚠ DANGER**

Electrocution. Do not manually transfer under load. Disconnect transfer switch from all power sources prior to manual transfer. Failure to do so will result in death or serious injury, and equipment damage.

(000132)

Prior to automatic operation, manually exercise the transfer switch to verify there is no interference with correct operation of the mechanism. Manual operation of the transfer switch is required if electronic operation should fail.

### Transfer to Generator Power Source

Proceed as follows to transfer to generator:

1. Verify generator is in OFF mode.
2. Set generator MLCB (generator disconnect) to OFF (OPEN).
3. Turn off utility power supply to the transfer switch using means provided (such as a utility MLCB).
4. Use the manual transfer handle (A in [Figure 3-4](#)) inside the transfer switch to move the main contacts to the STANDBY position (loads connected to the standby power source, B in [Figure 3-4](#)).

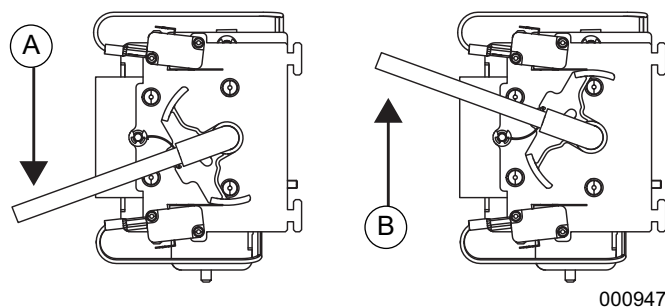

000947

**Figure 3-4. Manual Transfer Switch Operation**

5. Press MANUAL button to start engine.
6. Allow engine to stabilize and warm up for a few minutes.
7. Set generator MLCB (generator disconnect) to ON (CLOSED). Standby power source now powers the loads.

**IMPORTANT NOTE:** Actual switch operation may vary. Follow directions in the appropriate transfer switch manual.

### Transfer Back to Utility Power Source

When utility power has been restored, transfer back to utility source and shut down generator. Proceed as follows to manually transfer back to utility power and shut down generator:

1. Set generator MLCB (generator disconnect) to OFF (OPEN).
2. Allow engine to run for two minutes at no-load to stabilize internal temperatures.
3. Press OFF button. Engine will shut down.
4. Verify utility power supply to transfer switch is turned off.
5. See [Figure 3-4](#). Use manual transfer handle inside transfer switch to move main contacts to UTILITY position (A) (loads connected to utility power source).
6. Turn on utility power supply to transfer switch using the means provided (such as a utility MLCB).
7. Press control panel AUTO button.

## Automatic Transfer Operation

Proceed as follows to select automatic operation:

1. Verify transfer switch main contacts are set to UTILITY (loads connected to the utility power source).
2. Verify normal utility power source voltage is available to transfer switch terminal lugs N1 and N2.
3. Press AUTO button on control panel interface.
4. Set generator MLCB (generator disconnect) to ON (CLOSED).

Generator will start automatically when utility source voltage drops below a preset level. After the unit starts, loads are transferred to the standby power source.

## Automatic Sequence of Operation

### Utility Failure

With generator set to AUTO, when utility fails (below 65% of nominal) a five second line interrupt delay time is started. If utility is still gone when timer expires, engine will crank and start. Once started, a six second engine warm-up timer will be initiated (or a 30 second warm-up timer; see [Cold Smart Start](#)). When warm-up timer expires, the control panel will transfer the load to the generator. If the utility power is restored (above 80% nominal) at any time from the initiation of the engine start until the generator is ready to accept load (warm-up time has

not elapsed), the control panel will complete the start cycle and run the generator through its normal cool down cycle, however, the load will remain on the utility source.

### Cranking

The system will control cyclic cranking cycles as follows: 16 seconds crank, seven seconds rest, 16 seconds crank, seven seconds rest, followed by three additional cycles of seven seconds cranks followed by seven seconds rest. An alarm will be triggered if the generator does not start after five attempts.

### Cold Smart Start

Cold Smart Start allows generator to monitor ambient temperature. The warm-up delay will be adjusted based on prevailing conditions.

On a startup in AUTO mode, if ambient temperature is below a fixed temperature (based on model), generator will warm up for 30 seconds. This allows the engine to warm before a load is applied. If ambient temperature is at or above the fixed temperature, generator will start up with the normal warm-up delay of six seconds.

### Load Transfer

The transfer of load when the generator is running is dependent upon operating mode.

## Shutting Generator Down While Under Load or During a Utility Outage

### **⚠ DANGER**

Automatic start-up. Disconnect utility power and render unit inoperable before working on unit. Failure to do so will result in death or serious injury.

(000191)

**IMPORTANT NOTE:** To avoid equipment damage, follow these steps, in order, during utility outages. Shutdowns may be required during utility outages to perform routine maintenance or to conserve fuel.

#### To turn generator OFF:

1. Set utility MLCB to OFF (OPEN).
2. Set generator MLCB (generator disconnect) to OFF (OPEN).
3. Allow generator to run for cool-down for approximately one minute.
4. Set generator to OFF at the controller.
5. Remove 7.5A fuse from controller.

#### To turn generator back ON:

1. Install 7.5A fuse in controller.
2. Verify generator MLCB (generator disconnect) is OFF (OPEN).
3. Set generator to AUTO mode at the controller.

4. Generator will start and run. Allow generator to run and warm up for a few minutes.
5. Set generator MLCB (generator disconnect) to ON (CLOSED).
6. Set utility MLCB to ON (CLOSED).

The system now operates in automatic mode.

## Generator Emergency Shutdown Switch

### **⚠ CAUTION**

Equipment Damage. The emergency shutdown switch is not to be used to power down the unit under normal operating circumstances. Doing so will result in equipment damage. (000399a)

All generators are provided with an external means to shut down the generator which complies with the 2017 NEC code requirement. The primary generator shutdown sequence is described in [Shutting Generator Down While Under Load or During a Utility Outage](#).

See [Figure 3-5](#). An emergency shutdown switch is located on the exterior of the generator back panel. This emergency shutdown switch shuts down the generator and disables restarts.

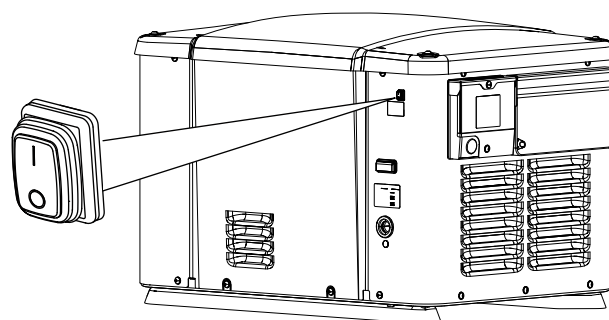

005570

**Figure 3-5. Emergency Shutdown Switch**

**NOTE:** Whenever possible, perform primary shutdown procedure before disabling generator with emergency shutdown switch.

**NOTE:** If emergency shutdown switch is OPEN (O), generator will not start. The controller displays a High Temperature alarm and the High Temperature LED on the controller flashes until the switch is closed (I). Once the switch is closed (I), the generator will return to either AUTO or OFF mode.

**NOTE:** The controller displays the same alarm message for either a High Temperature Alarm or an open emergency shutdown switch.

**This page intentionally left blank.**

## Section 4: Maintenance

### Maintenance

Regular maintenance will improve performance and extend engine/equipment life. Generac Power Systems, Inc. recommends that all maintenance work be performed by an Independent Authorized Service Dealer (IASD). Regular maintenance, replacement, or repair of the emissions control devices and systems may be performed by any repair shop or person of the owner's choosing. To obtain emissions control warranty service free of charge, the work must be performed by an IASD. See the emissions warranty.

### Performing Scheduled Maintenance

#### DANGER

Automatic start-up. Disconnect utility power and render unit inoperable before working on unit. Failure to do so will result in death or serious injury.

(000191)

#### WARNING

Equipment damage. Only qualified service personnel may install, operate, and maintain this equipment. Failure to follow proper installation requirements could result in death, serious injury, and equipment or property damage.

(000182a)

It is important to perform maintenance as specified in the [Service Schedule](#) for correct generator operation and to verify the generator complies with the applicable emission standards for the duration of its useful life. Service and repairs may be performed by any qualified service person or repair shop.

Additionally, emissions-critical maintenance must be performed as scheduled in order for the emissions warranty to be valid. Emissions-critical maintenance consists of servicing the air filter and spark plugs in accordance with the [Service Schedule](#). The control panel will prompt for break-in or regular maintenance, when it is required, to be performed. Break-in maintenance consists of the oil change, valve clearance, and tune-up. Regular maintenance includes the oil, tune-up, air cleaner, spark plug, and valve clearance.

**NOTE:** The control panel Maintenance Due light will flash when the initial 20 hour break-in interval has been reached. The same light will be lit solid when following regular maintenance intervals are required (every 1 year/100 hours).

### Clearing a Maintenance Due Condition

After performing maintenance, the Maintenance Due light must be cleared. To reset the Maintenance Due light, the generator must be in OFF mode. Set generator to OFF and press OFF button to reset maintenance due. If an alarm condition exists, the alarm condition must be cleared prior to resetting the Maintenance Due light.

## Service Schedule

System Component	Procedure			Frequency
X = Action * = Notify dealer if repair is needed	Inspect	Change	Clean	W = Weekly M = Monthly Y = Yearly
<b>Fuel</b>				
Fuel lines and connections	•			M
<b>Lubrication</b>				
Oil level	•			M or 24 hours of continuous operation
Oil		•		6 M or 100 hours of operation **
Enclosure louvers	•		•	W
<b>Battery</b>				
Remove corrosion; verify dryness	•		•	Y
Clean and tighten battery terminals	•		•	Y
Check charge state	•	•		Y
Electrolyte level (unsealed batteries only)*	•	•		Every 6 M
<b>Engine and mounting</b>				
Air cleaner	•	•	•	3 M / 50 hours - clean 1 Y / 300 hours - replace
Spark plug	•	•		6 M or 100 hours - inspect 1 Y or 300 hours - change
Valve clearance	•			1 Y or 300 hours***
<b>General condition</b>				
Vibration, noise, leakage *	•			M
<p><b>Contact the nearest Independent Authorized Service Dealer for assistance if necessary.</b></p> <p>* Contact the nearest Independent Authorized Service Dealer for assistance if necessary.</p> <p>** Change oil after the first 20 hours of operation or 1 month. Continue to check at intervals of 100 hours or 6 months, whichever occurs first. Severe duty oil drain intervals: In cold weather conditions (ambient below 40 °F [4.4 °C]) change engine oil every 6 months or 50 hours of operation to prevent accumulation of water in the oil. If the unit will be operated continuously in hot ambient conditions (ambient above 85 °F [29.4 °C]) or operation in an extremely dusty or dirty environment change the engine oil every 3 months or 50 hours of operation to prevent oil breakdown.</p> <p>*** Check valve clearance after the first 20 hours of operation. Continue to check at intervals of 300 hours.</p>				

**NOTE:** Contact an IASD or visit [www.generac.com](http://www.generac.com) for additional information on replacement parts.



# Maintenance Log

## Battery inspection and charge check

Dates Performed:

## Oil, oil filter, air filter and spark plug replacement

Dates Performed:

## Valve Adjustment

Dates Performed:

Notes:

## Checking Engine Oil Level



### ⚠️ WARNING

Risk of burns. Allow engine to cool before draining oil or coolant. Failure to do so could result in death or serious injury.

(000139)

### ⚠️ WARNING

Skin irritation. Avoid prolonged or repeated contact with used motor oil. Used motor oil has been shown to cause skin cancer in laboratory animals. Thoroughly wash exposed areas with soap and water.

(000210)

### ⚠️ CAUTION

Engine damage. Verify proper type and quantity of engine oil prior to starting engine. Failure to do so could result in engine damage.

(000135)

When power outages necessitate running the generator for extended periods, oil level must be checked daily. Proceed as follows to check engine oil level:

1. If generator is running during a utility outage, turn OFF all associated loads running in the residence using the main utility MLCB.
2. Set generator MLCB (generator disconnect) to OFF.
3. Press control panel OFF button.
4. Remove 7.5 amp fuse from generator control panel.
5. Remove enclosure top lid by unscrewing the fasteners, and lift front panel off.
6. Remove oil dipstick/fill cap and wipe it dry with a clean cloth.
7. Insert oil dipstick/fill cap, but do not thread into the crankcase threads, then again remove it.
8. See **Figure 4-1**. Verify oil level is within safe operating range. The level should be at the "H" (A) mark on oil dipstick/fill cap.

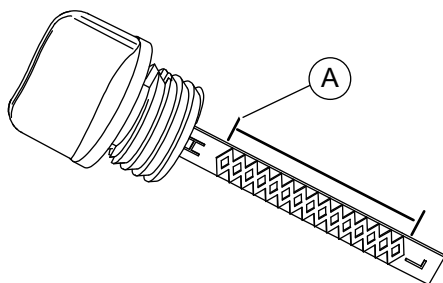

**Figure 4-1. Safe Oil Operating Range**

9. If necessary, remove oil dipstick/fill cap and add oil to the engine until oil level reaches FULL mark and insert oil dipstick/fill cap.
10. If generator was running during a utility outage, turn main utility MLCB to ON.
11. Install 7.5 amp fuse in generator control panel.
12. Press control panel AUTO button.
13. Turn ON needed loads in the residence.

## Engine Oil Recommendations

### ⚠️ CAUTION

Engine damage. Verify proper type and quantity of engine oil prior to starting engine. Failure to do so could result in engine damage.

(000135)

To maintain the product warranty, the engine oil should be serviced in accordance with the recommendations of this manual. Generac Maintenance Kits including engine oil, oil filter, air filter, spark plug(s), a shop towel, and funnel are available from an IASD.

All Generac Maintenance kits meet minimum American Petroleum Institute (API) Service Class SJ, SL, or better. Use no special additives. Select the appropriate viscosity oil grade according to the expected operating temperature. Synthetic oil also can be used in the appropriate weight as standard.

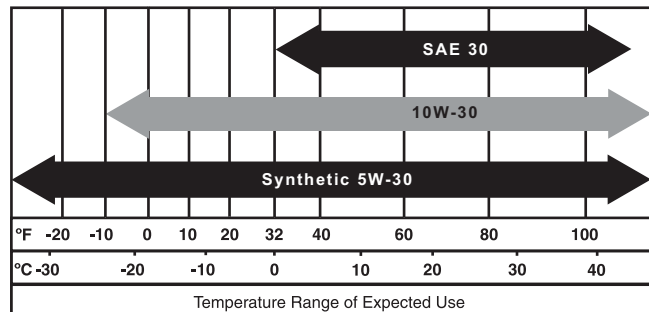

005799

**Figure 4-2. Recommended Oil Based on Temperature**

- SAE 30 above 32 °F (0 °C)
- SAE 10W-30 between -10 °F (4 °C) and above
- Synthetic SAE 5W-30 for all temperature ranges

## Changing the Oil

### **WARNING**

Skin irritation. Avoid prolonged or repeated contact with used motor oil. Used motor oil has been shown to cause skin cancer in laboratory animals. Thoroughly wash exposed areas with soap and water.

(000210)

Proceed as follows to change oil:

1. Press MANUAL button on control panel to start engine. Allow engine to run until it is thoroughly warmed up. Then, press OFF button to shut down engine.
2. Allow engine to cool for a few minutes, then remove enclosure top lid by unscrewing the fasteners, and lift front panel off.
3. See [Figure 4-3](#). Remove battery access panel (A) by loosening the two hex head screws. See [Figure 4-3](#).

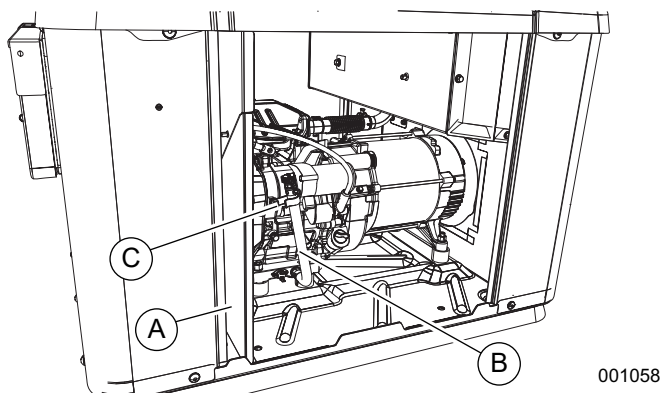

**Figure 4-3. Oil Drain Location**

4. Disconnect battery by removing negative battery cable then positive battery cable, and remove the fuse.
5. Pull oil drain hose (B) free of its retaining clip (C).
6. Remove oil drain hose cap and direct the hose into a suitable container.
7. Allow engine oil to drain. Remove oil dipstick/fill plug to permit oil to drain faster. For correct drainage, drain oil into a pan placed at a lower level than the engine.
8. After oil has drained, install oil drain hose cap onto the end of the oil drain hose. Position and secure the oil drain hose with the retaining clip.
9. Fill the engine with recommended oil. For recommended oil, see [Figure 4-2](#).
10. Connect battery, secure battery access panel, insert the fuse, and switch the unit to MANUAL.
11. Start engine, run for one minute, and inspect for leaks.
12. Shutdown engine and verify oil level. Add oil as needed. **DO NOT OVERFILL.**

13. Insert oil dipstick/fill cap and hand tighten.
14. Press control panel AUTO button.
15. Dispose of the used oil and filter according to local, state, or national laws.

## Changing the Engine Air Cleaner

Proceed as follows to change the engine air cleaner:

1. With generator shut down, remove top lid.
2. See [Figure 4-4](#). Disengage wire clip (A) and remove air cleaner access cover (B).

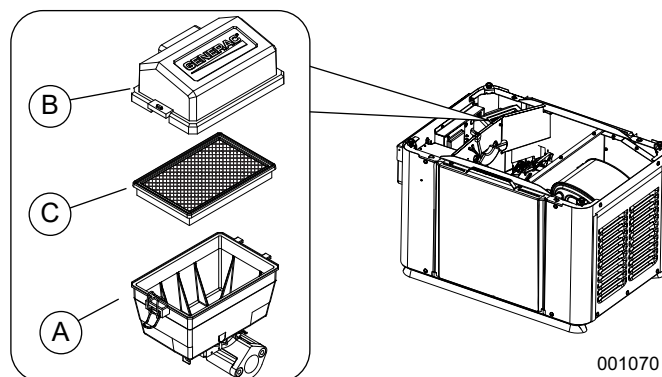

**Figure 4-4. Air Filter Location**

3. Remove old air filter (C) and discard.
4. Thoroughly clean air cleaner enclosure of any dust or debris while ensuring no debris falls in to the engine intake.
5. Install a new air filter.
6. Install air cleaner cover and engage wire clip.
7. Install enclosure top lid. Tighten fasteners securely.
8. Place generator in AUTO.

## Spark Plug

Proceed as follows to inspect spark plug gap and replace spark plug as necessary:

1. With generator shut down, remove top lid.
2. Clean the area around the base of the spark plug to keep dirt and debris out of the engine.
3. Gently pull spark plug boot off spark plug.
4. Remove spark plug and inspect condition. Install a new plug if old spark plug is worn, or if reuse is questionable.
5. Clean spark plug by scraping or washing with a wire brush and commercial solvent. Do not blast spark plug to clean.
6. See [Figure 4-5](#). Check spark plug gap using a wire feeler gauge. Spark plug gap should measure 0.030 in (0.76 mm). If spark plug gap is out of specification, replace spark plug. See [Replacement Parts](#).

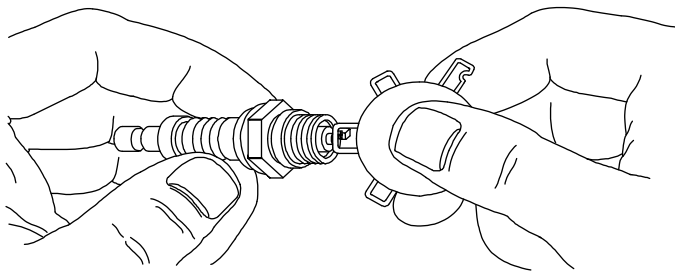

000211

**Figure 4-5. Spark Plug Gap Measurement**

7. Install spark plug. Tighten to 20–22 ft-lb (27–30 Nm).
8. Install spark plug boot.
9. Install enclosure top lid. Tighten fasteners securely.

## Valve Clearance Adjustment

Check the valve clearance after the first 20 hours of operation, then after 300 hour intervals. Adjust if necessary.

**IMPORTANT NOTE:** Contact an IASD for service assistance.

### Inspecting Valve Clearance

1. The engine should be cool before checking. Adjustment is not needed if valve clearance is within the specification. See [Specifications](#).
2. Turn the generator OFF.
3. Remove enclosure lid fasteners and lid. Then remove the back panel.
4. Remove spark plug wire and position wire away from plug.
5. Remove spark plug.
6. Make sure the piston is at top dead center (TDC) of its compression stroke (both valves closed). To get the piston at TDC, remove the intake screen at the front of the engine to gain access to the flywheel nut. Use a large socket and socket wrench to rotate the nut and hence the engine in a clockwise direction. While watching the piston through the spark plug hole. The piston should move up and down. The piston is at TDC when it is at its highest point of travel.
7. See [Figure 4-6](#). Check clearance between the rocker arm (C) and the valve stem (D) with a feeler gauge (E).

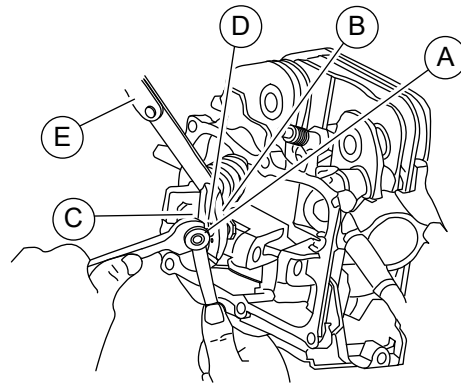

001071

**Figure 4-6. Valve Clearance Adjustment**

8. If valve clearance is 0.002–0.004 in (0.05–0.1 mm), adjustment is not needed.

### Adjusting Valve Clearance

Proceed as follows to adjust valve clearance:

**NOTE:** Engine should be cool before adjustment.

1. Remove enclosure lid fasteners and lid. Then remove back panel (if not already removed).
2. Remove spark plug wire and position spark plug wire away from spark plug.
3. Remove spark plug.
4. Remove the four screws attaching valve cover. Remove and discard gasket.
5. See [Figure 4-6](#). Loosen rocker jam nut (A) using a 10mm wrench.
6. Turn pivot ball stud (B) while checking clearance between rocker arm (C) and valve stem (D) with a feeler gauge (E). Correct clearance is 0.002–0.004 in (0.05–0.1 mm).

**NOTE:** Hold rocker arm jam nut in place as pivot ball stud is turned.

7. When valve clearance is correct, hold pivot ball stud in place with the wrench and tighten the rocker arm jam nut. Tighten jam nut to 174 **in-lbs** (19.68 Nm) torque. After tightening jam nut, check valve clearance to verify it did not change.
8. Install new valve cover gasket.
9. Install the valve cover. Tighten fasteners in a cross pattern, tightening to 35–62 **in-lbs** (4–7 Nm).

**NOTE:** Start all four screws before tightening or it will not be possible to get all the screws in place. Verify valve cover gasket is in place.

10. Install rubber plug into fan screen.
11. Install spark plug and attach spark plug wire.

12. Install back panel. Verify alternator intake bellow is captured by the frame on back panel securely with out any kinks. Install enclosure top lid. Tighten all fasteners securely.
13. Place generator in AUTO.

## Battery Maintenance



### ⚠️ WARNING

Explosion. Do not dispose of batteries in a fire. Batteries are explosive. Electrolyte solution can cause burns and blindness. If electrolyte contacts skin or eyes, flush with water and seek immediate medical attention.

(000162)



### ⚠️ WARNING

Explosion. Batteries emit explosive gases while charging. Keep fire and spark away. Wear protective gear when working with batteries. Failure to do so could result in death or serious injury.

(000137a)



### ⚠️ WARNING

Electrical shock. Disconnect battery ground terminal before working on battery or battery wires. Failure to do so could result in death or serious injury.

(000164)



### ⚠️ WARNING

Risk of burns. Batteries contain sulfuric acid and can cause severe chemical burns. Wear protective gear when working with batteries. Failure to do so could result in death or serious injury.

(000138a)

### ⚠️ WARNING

Environmental Hazard. Always recycle batteries at an official recycling center in accordance with all local laws and regulations. Failure to do so could result in environmental damage, death, or serious injury. (000228)

Always recycle batteries in accordance with local laws and regulations. Contact your local solid waste collection site or recycling facility to obtain information on local recycling processes. For more information on battery recycling, visit the Battery Council International website at: <http://batteryCouncil.org>.

The battery should be regularly inspected per the **Service Schedule**. Proceed as follows to perform battery maintenance:

1. With generator shut down, lift lid and remove front panel and battery access panel.
2. Inspect battery posts and battery cables for tightness and corrosion. Tighten and clean as necessary.

3. Check battery fluid level of unsealed batteries, and if necessary, fill with distilled water only. DO NOT use tap water. Also, have an IASD verify the state of charge and condition.

Strictly observe the following precautions when working on batteries:

- Remove 7.5 amp fuse from generator control panel.
- Remove all jewelry (watches, rings, metal objects, etc.).
- Use tools with insulated handles.
- Wear rubber gloves and boots.
- Do not place tools or metallic objects on top of the battery.
- Disconnect charging source by pulling T1 fuse in the transfer switch prior to connecting or disconnecting battery terminals.
- Wear full eye protection and protective clothing.
- Where electrolyte contacts skin, wash it off immediately with water.
- Where electrolyte contacts the eyes, flush thoroughly and immediately with water and seek medical attention.
- Wash down spilled electrolyte with an acid neutralizing agent. A common practice is to use a solution of 1 lb (500 g) bicarbonate of soda to 1 gal (4 L) of water. The bicarbonate of soda solution is to be added until the evidence of reaction (foaming) has ceased. The resulting liquid is to be flushed with water and the area dried.
- DO NOT smoke when near battery.
- DO NOT cause flame or spark in battery area.
- Discharge static electricity from the body before touching the battery by first touching a grounded metal surface.

## Attention After Submersion

If generator has been submerged in water, it MUST NOT be started and operated. Following any submersion in water, have an IASD thoroughly clean, dry, and inspect the generator. If the structure (home) has been flooded, it should be inspected by a certified electrician to verify there won't be any electrical problems during generator operation or when utility power is returned.

## Corrosion Protection

Periodically wash and wax the enclosure using automotive type products. Do not spray unit with a hose or power washer. Use warm, soapy water and a soft cloth. Frequent washing is recommended in salt water/coastal areas. Spray engine linkages with a light oil such as WD-40®.

## Remove From, and Return To Service Procedure

### Remove From Service

If generator cannot be exercised every seven days and will be out of service longer than 90 days, proceed as follows to prepare generator for storage:

1. Start engine and let it warm up.
2. Close fuel shutoff valve in fuel supply line and allow unit to shut down.
3. Once unit has shut down, set generator MLCB (generator disconnect) to OFF (OPEN).
4. Turn off utility power to transfer switch.
5. Remove 7.5 amp fuse from generator control panel.
6. Disconnect battery cables. Remove negative battery cable first.
7. Remove battery charger AC input T1/Neutral cable (with white sleeve) at controller.
8. While engine is still warm, drain oil completely, and then fill crankcase with oil.
9. Attach a tag to engine indicating viscosity and classification of the new oil in the crankcase.
10. Remove spark plug and spray a fogging agent into the spark plug threaded openings. Install and tighten spark plug.
11. Remove battery and store it in a cool, dry room.
12. Clean and wipe down entire generator.

### Return to Service

Proceed as follows to return unit to service after storage:

1. Verify utility power is OFF.
2. Inspect engine tag for oil viscosity and classification. If necessary, drain and fill with recommended oil.
3. Inspect state of battery. Fill all cells of unsealed batteries to correct level with distilled water. DO NOT use tap water. Charge battery to FULL state of charge. If completely discharged, replace battery.
4. Clean and wipe down entire generator.
5. Verify 7.5 amp fuse is removed from generator control panel.
6. Connect battery. Observe battery polarity. Damage may occur if the battery is connected incorrectly. Install positive battery cable first.
7. Connect battery charger AC input T1/Neutral cable (with white sleeve) at controller.
8. Open fuel shutoff valve.
9. Insert 7.5 amp fuse into generator control panel.
10. Start unit by pressing MANUAL button. Allow unit to warm up for a few minutes.

11. Stop unit by pressing control panel OFF button.
12. Turn on utility power to transfer switch.
13. Set control panel to AUTO.

Generator is ready for service.

**NOTE:** When a battery is completely discharged or has been disconnected, the exercise timer and current date and time must be reset.

## Section 5: Troubleshooting

### Generator Troubleshooting

Problem	Cause	Correction
Engine will not crank	Blown fuse.	Correct short circuit condition by replacing 7.5 amp fuse in generator control panel.
	Loose, corroded, or faulty battery cables.	Tighten, clean, or replace as necessary. Contact an IASD.
	Faulty starter contact.	
	Faulty starter motor.	
	Completely discharged battery.	Charge or replace battery.
	Emergency shutdown switch is OPEN (O).	Set emergency shutdown switch to CLOSED (I) position and clear alarm.
Engine cranks but will not start	Insufficient fuel.	Replenish fuel / Turn on fuel valve.
	Faulty fuel solenoid (FS).	
	Faulty spark plug.	Clean spark plug, verify spark plug gap or replace spark plug.
	Valve clearance out of adjustment.	Adjust valve clearance.
	In cold weather condition.	Install recommended cold weather kit.
Engine starts hard and runs rough	Air cleaner plugged or damaged.	Inspect / replace air cleaner.
	Faulty spark plug(s).	Clean spark plug, verify spark plug gap or replace spark plug.
	Fuel pressure incorrect.	Verify fuel pressure to regulator is 10–12 in water column (2.49–2.99 kPa) for LP, and 5–7 in water column (0.87–1.74 kPa) for NG.
	Fuel selector in wrong position.	Set fuel conversion valve to correct position. Contact an IASD.
Generator is set to OFF, but the engine continues to run	Controller wired incorrectly	Contact an IASD.
	Faulty control board.	
No AC output from generator	Generator MLCB (generator disconnect) is OFF (OPEN).	Set generator MLCB (generator disconnect) to ON (or CLOSED).
	Generator internal failure.	Contact an IASD.

Problem	Cause	Correction
No transfer to standby after utility source failure	Generator MLCB (generator disconnect) is OFF (OPEN).	Set generator MLCB (generator disconnect) to ON (or CLOSED).
	Faulty transfer switch coil.	Contact an IASD.
	Faulty transfer relay.	
	Transfer relay circuit open.	
Unit consumes large amounts of oil	Engine overfilled with oil.	Adjust oil to correct level.
	Faulty engine breather.	Contact an IASD.
	Incorrect type or viscosity of oil.	See <a href="#">Engine Oil Requirements</a> .
	Damaged gasket, seal, or hose.	Inspect for oil leaks.

**NOTE:** IASD must have an active Tech ID and be air-cooled certified to perform any warrantable repairs and submit warranty claims related to air-cooled products.



## Quick Reference Guide

To clear an active alarm, press the OFF button twice and then press AUTO. If alarm reoccurs, contact an air-cooled certified IASD.

Active Alarm	Problem	Action	Solution
NONE	Unit running in AUTO but no power in house.	Check generator MLCB (generator disconnect).	Check generator MLCB (generator disconnect). If it is ON (CLOSED), contact an IASD.
HIGH TEMPERATURE	Unit shuts down during operation.	Check controller for alarms.	Inspect ventilation around generator, intake, exhaust and rear of generator. If no obstructions exist, contact an IASD.
HIGH TEMPERATURE	Unit will not start.	Check emergency shutdown switch position.	Set emergency shutdown switch to CLOSED (I) position.
RPM SENSE LOSS	Unit was running and shuts down, attempts to restart.	Check controller for alarms.	Clear alarm and remove household loads from generator. Put back in AUTO and restart. If generator does not start, contact an IASD.
NOT ACTIVATED	Unit will not start in AUTO with utility loss.	Observe if all six Alarm and Warning LEDs are blinking simultaneously.	See Generator Activation in the installation manual.
LOW OIL PRESSURE	Unit will not start in AUTO with utility loss.	Check controller for alarms.	Check oil level / add oil as needed. If oil level is correct, contact an IASD.
OVERCRANK	Unit will not start in AUTO with utility loss.	Check controller for alarms.	Verify fuel line shutoff valve is in the ON position. Clear alarm. Attempt to start the unit in MANUAL. If it does not start or starts and runs rough, contact an IASD.
NO LEDs LIT	Unit will not start in AUTO with utility loss.	Check controller for alarms.	Check ATO 7.5 amp ATO <sup>®</sup> fuse. Replace with same type fuse if bad. Contact an IASD if fuse is good.
SPEED ALARM	Unit will not start in AUTO with utility loss.	Check controller for alarms.	Contact an IASD.
WIRING ERROR	Unit will not start in AUTO with utility loss.	Check controller for alarms.	Contact an IASD.
BATTERY PROBLEM	Yellow LED steadily illuminated	Check controller for additional information.	Contact an IASD.
CHARGER PROBLEM	Yellow LED flashes	Check controller for additional information.	Contact an IASD.
BREAK-IN MAINTENANCE DUE	Control panel indicates break-in maintenance due.LED flashes.	None	Perform break-in maintenance. Clear maintenance due light.
1 YEAR / 100 HOUR MAINTENANCE DUE	Control panel indicates scheduled maintenance due.LED illuminates.	None	Perform scheduled maintenance. Clear maintenance due light.
NONE	Utility present. Generator running. Active mode LED (AUTO/MANUAL/OFF) is flashing.	Check utility sense lines / utility disconnect.	Contact an IASD. Close utility disconnect.

**This page intentionally left blank.**



Part No. 10000021790 Rev. C 06/12/2023  
©2023 Generac Power Systems, Inc.  
All rights reserved.  
Specifications are subject to change without notice.  
No reproduction allowed in any form without prior written  
consent from Generac Power Systems, Inc.

**GENERAC®**

Generac Power Systems, Inc.  
S45 W29290 Hwy. 59  
Waukesha, WI 53189  
1-888-GENERAC (1-888-436-3722)  
[www.generac.com](http://www.generac.com)