



IQ System Controller 3/3G

The Enphase IQ System Controller 3/3G connects the home to grid power, the IQ Battery system, and solar PV. It provides microgrid interconnect device (MID) functionality by automatically detecting and seamlessly transitioning the home energy system from grid power to backup power in the event of a grid failure. It consolidates interconnection equipment into a single enclosure and streamlines grid-independent capabilities of PV and storage installations by providing a consistent, pre-wired solution for residential applications.



IQ Series Microinverters
The high-powered smart grid-ready IQ Series Microinverters (M Series, IQ6, IQ7, and IQ8 Series) dramatically simplify the installation process.



IQ Battery 5P
Fully integrated AC battery system. Includes six field-replaceable IQ8D-BAT microinverters.



IQ Combiner 5/5C
Consolidates PV interconnection equipment into a single enclosure and streamlines IQ Series Microinverters and IQ Gateway installation by providing a consistent, pre-wired solution for residential applications.



IQ Load Controller
Helps prioritize essential appliances during a grid outage to optimize energy consumption and prolong battery life.

Easy to install

- Connects to service entrance¹ or main load center
- Includes neutral-forming transformer
- Mounts on single stud with centered brackets
- Provides conduit entry from the bottom, left, or right
- Includes color-coded wires for ease of wiring the System Shutdown Switch
- Integrates hold-down functionality to eliminate the need for hold-down kits and special breakers

Flexible

- Can be used for Sunlight Backup, Home Essentials Backup, or Full Energy Independence
- IQ System Controller 3 integrates with IQ Battery 5P
- IQ System Controller 3G integrates with select AC standby generators. See the [Generator integration tech brief](#) for a list of generators
- Provides a seamless transition to backup

Safe and reliable

- System Shutdown Switch can be used to disconnect PV, battery, and generator systems
- The System Shutdown Switch acts as a rapid shutdown initiator of grid-forming IQ8 PV Microinverters for the safety of maintenance technicians/first responders
- 10-year limited warranty



IQ System Controller 3



IQ System Controller 3G

¹ IQ System Controller 3 is not suitable for use as service equipment in Canada.

IQ System Controller 3/3G

MODEL NUMBER	DESCRIPTION
SC200D111C240US01	IQ System Controller 3 streamlines the grid-independent capabilities of PV and storage installations. Integrates hold-down capability. Supports IQ Battery 5P units up to 40 kWh (without PCS*) and 80 kWh (with PCS*). Does not support generator integration
SC200G111C240US01	IQ System Controller 3G streamlines the grid-independent capabilities of PV and storage installations. Integrates hold-down capability. Supports IQ Battery 5P units up to 20 kWh (without PCS*) and 40 kWh (with PCS*). Supports generator integration
WHAT IS IN THE BOX	
IQ System Controller 3/3G	Includes neutral-forming transformer (NFT) and microgrid interconnect device (MID)
System Shutdown Switch	Includes pre-wired red, black, orange, and purple 12 AWG wire (EP200G-NA-02-RSD)
Wall-mounting bracket	Screws provided in the accessories kit for mounting
4-pole circuit breaker	Pre-installed quad breaker (BRK-20A40A-4P-240V), 20 A-40 A, 10 kAIC, Eaton BQC220240 ²
Accessories kit	IQ System Controller 3/3G literature kit, including labels, CTRL headers, screws, filler plates, and quick install guide (QIG) (EP200G-LITKIT)
OPTIONAL ACCESSORIES AND REPLACEMENT PARTS	
CT-200-SPLIT	200 A split-core current transformers for metering (accuracy: $\pm 2.5\%$) ³
CT-200-CLAMP	200 A clamp-type current transformers for metering (accuracy: $\pm 2.5\%$) ³
Main or load circuit breakers (order separately, as needed) ⁴	<ul style="list-style-type: none"> BRK-100A-2P-240V : 2-pole, 100A, 25kAIC, CSR2100N or CSR2100 BRK-125A-2P-240V: 2-pole, 125A, 25kAIC, CSR2125N BRK-150A-2P-240V: 2-pole, 150A, 25kAIC, CSR2150N BRK-175A-2P-240V: 2-pole, 175A, 25kAIC, CSR2175N BRK-200A-2P-240V: 2-pole, 200A, 25kAIC, CSR2200N
Distributed energy resource (DER) circuit breakers (order separately, as needed) ⁵	<ul style="list-style-type: none"> BRK-20A-2P-240V-B: 2-pole, 20 A, 10 kAIC, BR220B/BR220 BRK-30A-2P-240V-B: 2-pole, 30 A, 10 kAIC, BR230 BRK-40A-2P-240V-B: 2-pole, 40 A, 10 kAIC, BR240B/BR240 BRK-60A-2P-240V: 2-pole, 60 A, 10 kAIC, BR260 BRK-80A-2P-240V: 2-pole, 80 A, 10 kAIC, BR280
EP200G-HNDL-R1	IQ System Controller 3/3G installation handle kit (order separately)
CTRL-SC3-NA-01	Control cable, 500 ft. spool (order separately)
BRK-20A40A-4P-240V	2-pole 20 A, 2-pole 40 A, 10 kAIC, Quad Breaker BQC220240 ⁶
ALTERNATE DER CIRCUIT BREAKERS	
GE/ABB	THQL21xx (20/40/60/80 A)
Siemens	Q2xx (20/40/60/80 A)
Siemens (quad breaker)	Q2402OCT2 (20/40 A)
ELECTRICAL SPECIFICATIONS	
Nominal voltage/Range (L-L)	240 V ⁷ $\sim \pm 20\%$
Voltage measurement accuracy	$\pm 1\%$ V nominal (± 1.2 V L-N and ± 2.4 V L-L)
Auxiliary (dry) contact for load control, excess PV control, and generator two-wire control	24 V, 1 A
Nominal frequency/Range	60 Hz/56–63 Hz
Frequency measurement accuracy	± 0.1 Hz
Maximum continuous current rating	160 A
Maximum input overcurrent protection device	200 A
Maximum output overcurrent protection device	200 A
Maximum overcurrent protection device rating for generator circuit	80 A (IQ System Controller 3G only - SC200G111C240US01)
Maximum overcurrent protection device rating for storage circuit	2 × 80 A (IQ System Controller 3 - SC200D111C240US01) 1 × 80 A (IQ System Controller 3G - SC200G111C240US01)

² Factory-installed quad breaker (Siemens or Eaton). NFT pre-wired to 40 A terminal of the quad breaker.

³ Two units of CT-200-SPLIT or CT-200-CLAMP must be bought separately for generator integration.

⁴ The IQ System Controller 3 is rated at 22 kAIC.

⁵ Integrated hold-down kit support breakers (BR230/BR230/BR240) without predrilled hole. The integrated hold-down kit also supports GE/ABB and Siemens as mentioned in the *Alternate DER circuit breakers* section.

⁶ Figures 1a and 1b show Siemens or Eaton factory-installed quad breakers with NFT pre-wired to 40 A.

⁷ "-" indicates alternating current (AC) supply.

* Power control system.

ELECTRICAL SPECIFICATIONS									
Maximum overcurrent protection device rating for PV combiner unit	80 A								
Internal busbar rating	200 A								
Neutral-forming transformer (NFT)	<ul style="list-style-type: none"> • Breaker rating (pre-installed): 40 A between L1 and Neutral; 40 A between L2 and Neutral • Continuous rated power: 3,600 VA • Maximum continuous unbalance current: 30 A @ 120 V • Peak unbalanced current: 80 A @ 120 V for two seconds 								
MECHANICAL DATA									
Dimensions (W × H × D)	50 cm × 91.6 cm × 24.6 cm (19.7 in × 36 in × 9.7 in)								
Weight	39.4 kg (87 lb)								
Ambient temperature range	-40°C to 50°C (-40°F to 122°F)								
Cooling	Natural convection and a heat shield								
Enclosure environmental rating	Outdoor, NEMA type 3R, polycarbonate construction								
Maximum altitude	2,500 m (8,200 ft)								
WIRE SIZES									
Connections (All lugs are rated to 90°C)	<table border="0"> <tr> <td>Main lugs and backup load lugs Cu/Al:</td> <td>6 AWG–300 kcmil</td> </tr> <tr> <td>CSR breaker bottom wiring lugs Cu/Al:</td> <td>2 AWG–300 kcmil</td> </tr> <tr> <td>AC combiner lugs, IQ Battery lugs, and generator lugs:</td> <td>14 AWG–2 AWG</td> </tr> <tr> <td>Neutral (large lugs) Cu/Al:</td> <td>6 AWG–300 kcmil</td> </tr> </table>	Main lugs and backup load lugs Cu/Al:	6 AWG–300 kcmil	CSR breaker bottom wiring lugs Cu/Al:	2 AWG–300 kcmil	AC combiner lugs, IQ Battery lugs, and generator lugs:	14 AWG–2 AWG	Neutral (large lugs) Cu/Al:	6 AWG–300 kcmil
Main lugs and backup load lugs Cu/Al:	6 AWG–300 kcmil								
CSR breaker bottom wiring lugs Cu/Al:	2 AWG–300 kcmil								
AC combiner lugs, IQ Battery lugs, and generator lugs:	14 AWG–2 AWG								
Neutral (large lugs) Cu/Al:	6 AWG–300 kcmil								
Neutral and ground bars	<table border="0"> <tr> <td>Large holes (5/16–24 UNF)</td> <td>14 AWG–1/0 AWG</td> </tr> <tr> <td>Small holes (10–32 UNF)</td> <td>14 AWG–6 AWG</td> </tr> </table>	Large holes (5/16–24 UNF)	14 AWG–1/0 AWG	Small holes (10–32 UNF)	14 AWG–6 AWG				
Large holes (5/16–24 UNF)	14 AWG–1/0 AWG								
Small holes (10–32 UNF)	14 AWG–6 AWG								
COMPLIANCE									
Compliance	UL 1741, UL 1741 SA, IEEE 1547:2018 (UL 1741-SB, 3rd Ed.), UL 1741 PCS CRD, UL1 998, UL 869A, UL 508 ⁸ , UL 50E ⁸ CSA 22.2 No. 107.1, 47 CFR Part 15 Class B, ICES 003, ICC ES AC156 The IQ System Controller 3/3G is approved for use as service equipment in the United States								
WARRANTY									
Limited warranty (restrictions apply)	Up to 10 years (EP200G-NA-02-RSD has a 5-year warranty)								
COMPATIBILITY ⁹									
Battery	IQ Battery 5P (IQBATTERY-5P-1P-NA)								
Microinverters	IQ8, IQ7, IQ6, and M Series Microinverters ¹⁰								
IQ Combiner	IQ Combiner 5/5C (X-IQ-AM1-240-5C and X-IQ-AM1-240-5)								
Communications Kit 2	COMMS-KIT-02								

⁸ Sections from these standards were used during the safety evaluation and included in the UL 1741 listing.

⁹ For more details, refer to the IQ System Controller 3/3G quick install guide.

¹⁰ M Series Microinverters can only be supported in states that have not yet adopted IEEE 1547:2018. Enphase does not support mixing IQ8 Series Microinverters with other series on the same IQ Gateway.

Figure 1A: Installing DER breakers for IQ8 system without generator

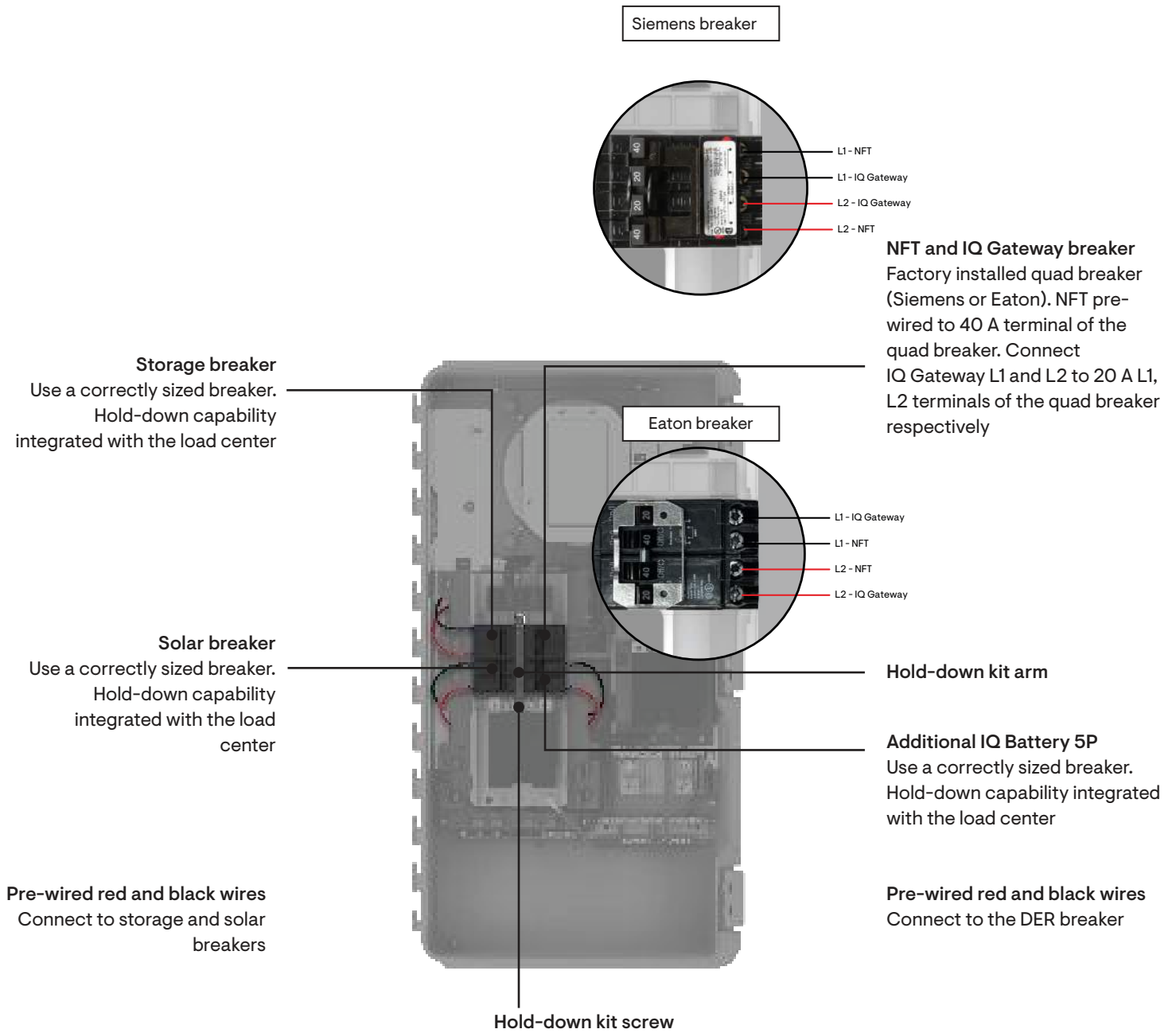

Figure 1B: Installing DER breakers for IQ8 system with generator

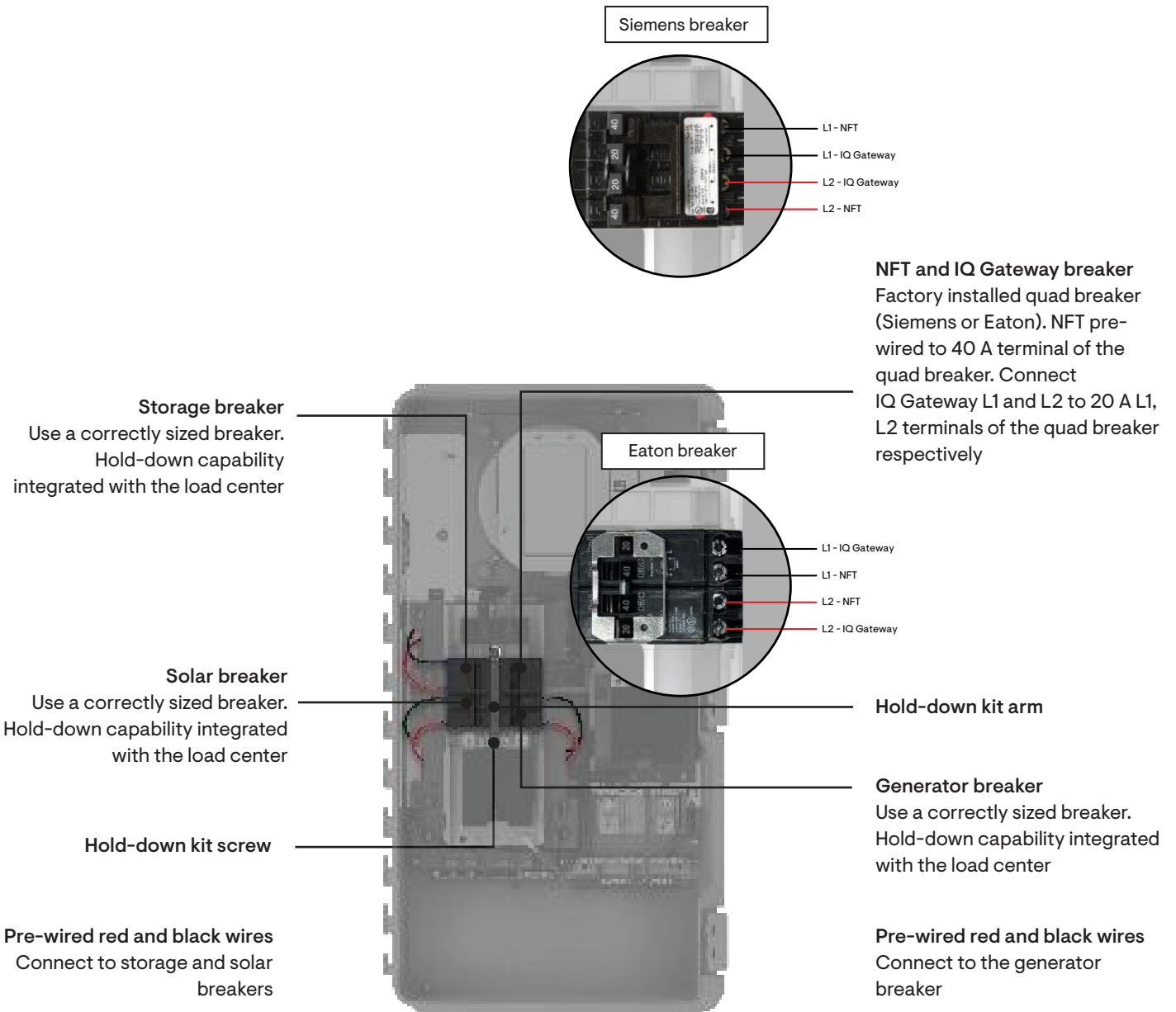
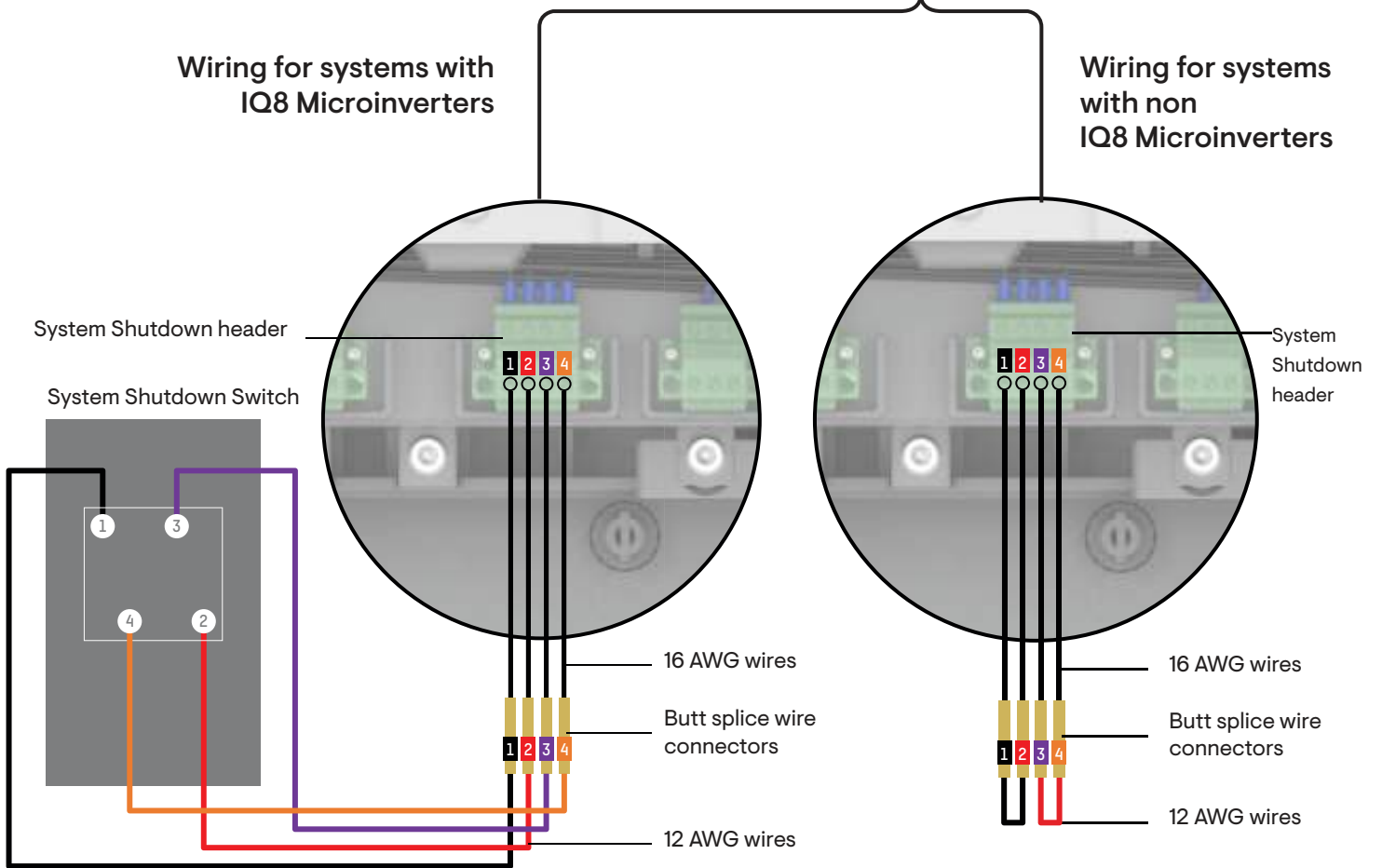
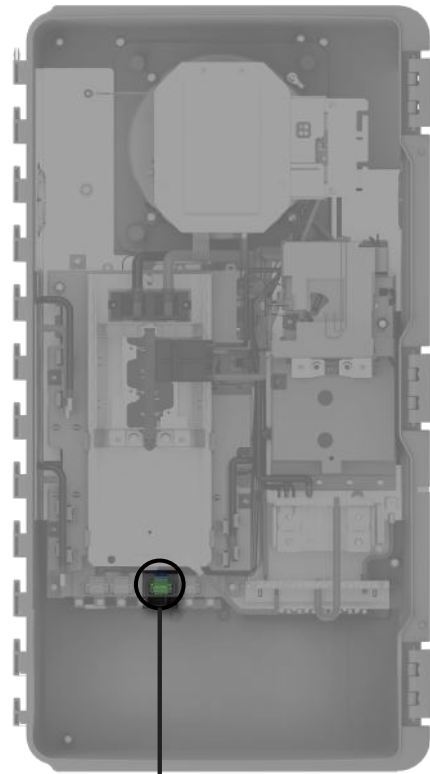

Figure 2: Wiring the System Shutdown Switch



Revision history

REVISION	DATE	DESCRIPTION
DSH-00021-5.0	August 2024	Updated the "Compliance" section.
DSH-00021-4.0	May 2024	Updated the section "Optional accessories and replacement parts" and the UL certification.
DSH-00021-3.0	August 2023	Updated the section "Optional accessories and replacement parts".
DSH-00021-2.0	July 2023	Added new section "Alternative breakers for Eaton load center".
DSH-00021-1.0	May 2023	Initial release.