

IQ System Controller 3/3G

Quick install guide



Scan the QR code to access
the latest document



MODEL NUMBERS-
SC200D111C240US01
SC200G111C240US01

VERSION 9.0
AUGUST 2024



148-00271-09

The third generation of the IQ System Controller features the following variants: IQ System Controller 3 (SC200D111C240US01) and IQ System Controller 3G (SC200G111C240US01).

IQ System Controller 3 and IQ System Controller 3G are not interchangeable in the field.

The IQ System Controller 3G supports one PV and one IQ Battery 5P port. A third distributed energy resource (DER) port is dedicated to generator integration, which is interlocked via hardware with the MID. IQ System Controller 3 supports additional IQ Battery 5P on the third DER port.

To install the IQ System Controller and wall-mount bracket, read and follow all warnings and instructions in this guide and documents at <https://enphase.com/support>.

Enphase field engineering team can provide a digital copy of production line test results upon request with the equipment's serial number. Requests can be raised through <https://enphase.com/support>.

To access the latest technical brief and user guides for generator integration, see the Generator Support page at <https://enphase.com/installers/storage/generator>.

Safety warnings are listed at the end of this guide. These instructions are not meant to be a complete explanation of how to design and install an energy storage system. All installations must comply with national and local electrical codes and standards. Only qualified electricians shall install, troubleshoot, or replace the IQ System Controller 3/3G.

The Enphase IQ System Controller 3/3G supports a 240 V L-L/120 V L-N split phase supply (i.e., two phases that have a phase angle of 180°). For use with grid supplies other than a split phase, an appropriate external transformer must be provided to convert the incoming supply from the utility to a split phase supply. Sizing of the transformer must be done per system requirements and must be sufficient to cover the load and distributed energy resource (DER) requirements. Local and national electrical codes, as well as utility interconnection requirements, must be met by the installer when using an external transformer.



⚠ WARNING: Before installing, it is crucial to carefully follow the instructions provided. To guarantee maximum reliability and comply with warranty requirements, it is essential to install the IQ System Controller according to the recommendations outlined in this guide.

✔ NOTE: Enphase Energy Systems require a utility grid connection for commissioning and operation.

Table of contents

Scenario 1

Full Energy Independence configuration

Whole home backup with IQ System Controller 3

Scenario 1a

Full Energy Independence configuration

Whole home backup with IQ System Controller 3G

Scenario 2

Home Essentials Backup configuration

Partial home backup with IQ System Controller 3

Scenario 2a

Home Essentials Backup configuration

Partial home backup with IQ System Controller 3G

Scenario 3

Sunlight Backup

Scenario 3a

Sunlight Backup with generator

Compatibility

Specifications

Electrical specifications

Mechanical specifications

What's in the box

Tools/additional items required

Section A

Mounting the product

Plan a location for the IQ System Controller

Step 1: Minimum clearance

Step 2: Install the mounting bracket

Step 3: Open the dead front

Section B

Mounting the breakers

Internal view of IQ System Controller 3/3G

Wiring for service entrance

Install mains and backup breakers

Breakers for IQ8 Systems without generator

Breakers for IQ8 Systems with generator

Breakers for NFT and IQ Gateway breaker

Section C

Wiring

Drill conduits

DER wiring

Aux wiring: System Shutdown Switch

Aux wiring: IQ Load Controller

Aux wiring: Generator control

Mains/supply side wiring

Backup loads wiring

CT wiring

Wiring control (CTRL) cable to headers

Control (CTRL) wiring between system components

Section D

Power Control System (PCS)

Introduction

Setting up PCS on-site during commissioning

Close and energize IQ System Controller

Safety

Addendum A: Wire sizes and tightening torque

Revision history

With the flexibility offered by Enphase Energy System, customers can choose to install a system that caters to their current and future energy needs. The following illustrative scenarios showcase some of the capabilities.

Scenario 1

Whole home backup with IQ System Controller 3

This is the preferred configuration for the backup of the entire main load panel. This configuration supports up to an 80 A breaker for PV and up to two times 80 A breakers for the IQ Batteries.

The microinverter ranges supported in this configuration are IQ8, IQ7, IQ6, or M Series.

Check for [Compatibility](#).

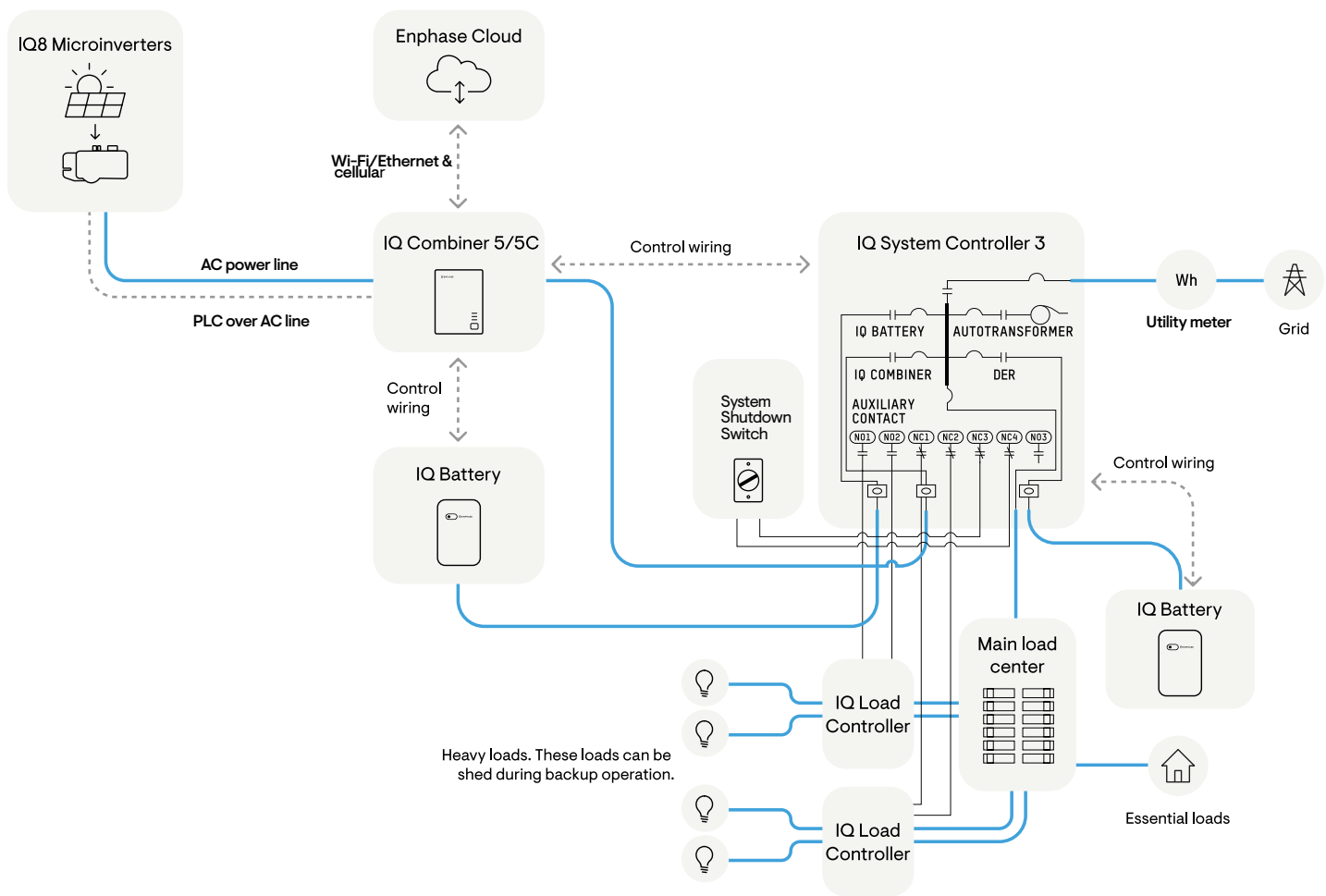

ⓘ **NOTE:** The System Shutdown Switch is not used for IQ6, IQ7, and M Series systems. Refer to the [Section C - Wiring](#) for details.

This figure shows the system configuration. For wiring, follow the details in the wiring section.

Scenario 1a

Whole home backup with IQ System Controller 3G

This is the preferred configuration for the backup of the entire main load panel. This configuration supports up to an 80 A breaker each for the PV, IQ Battery, and generator (optional).

The microinverter ranges supported in this configuration are IQ8, IQ7, IQ6, or M Series.

Check for [Compatibility](#).

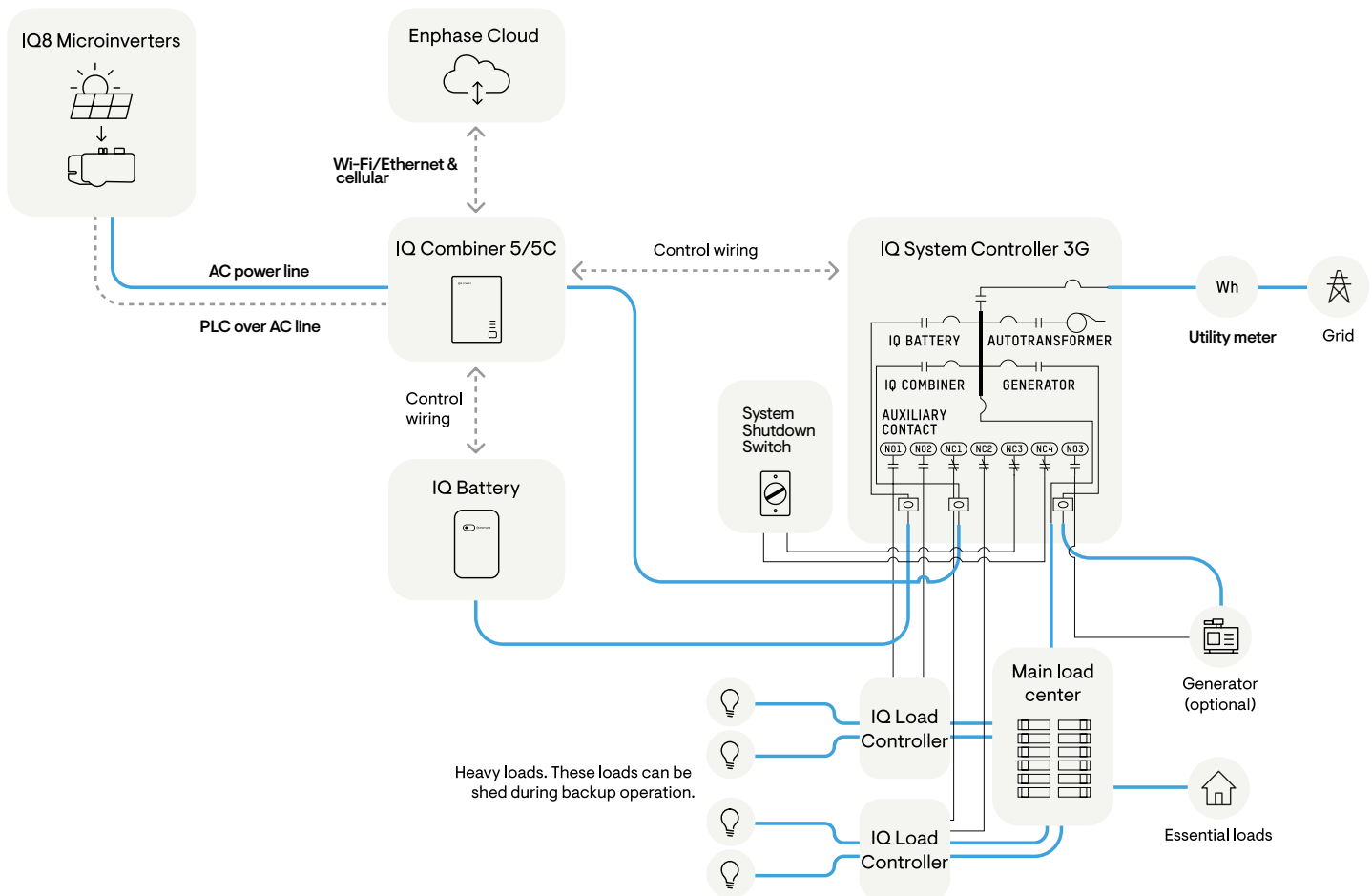

✓ **NOTE:** The System Shutdown Switch is not used for IQ6, IQ7, and M Series systems. Refer to the [Section C - Wiring](#) for details.

This figure shows the system configuration. For wiring, follow the details in the wiring section.

Additional wiring and components are required when integrating generators. Refer to the Generator integration page for technical briefs and guides <https://enphase.com/installers/storage/generator>.

Scenario 2

Partial home backup with IQ System Controller 3

This is the preferred configuration for partial home backup with PV and IQ Batteries.

The microinverter ranges supported in this configuration are IQ8, IQ7, IQ6, or M Series.

Check for [Compatibility](#).

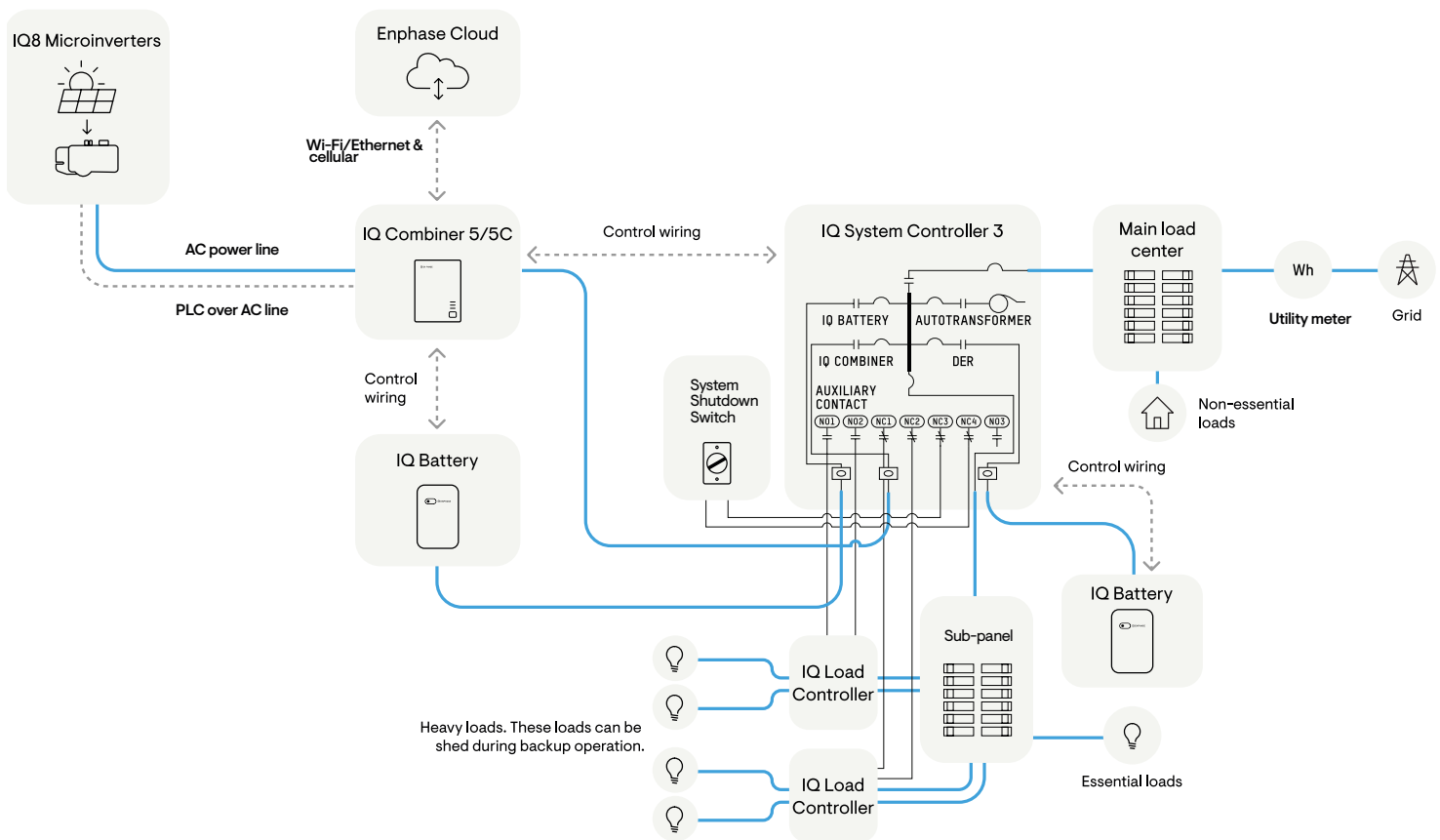

NOTE: The System Shutdown Switch is not used for IQ6, IQ7, and M Series systems. Refer to the [Section C - Wiring](#) section for details.

This figure shows the system configuration. For wiring, follow the details in the wiring section.

Scenario 2a

Partial home backup with IQ System Controller 3G

This is the preferred configuration for partial home backup with PV and IQ Batteries. A generator can be integrated with IQ System Controller 3G based on the homeowner's needs.

The microinverter ranges supported in this configuration are IQ8, IQ7, IQ6, or M Series.

Check for [Compatibility](#).

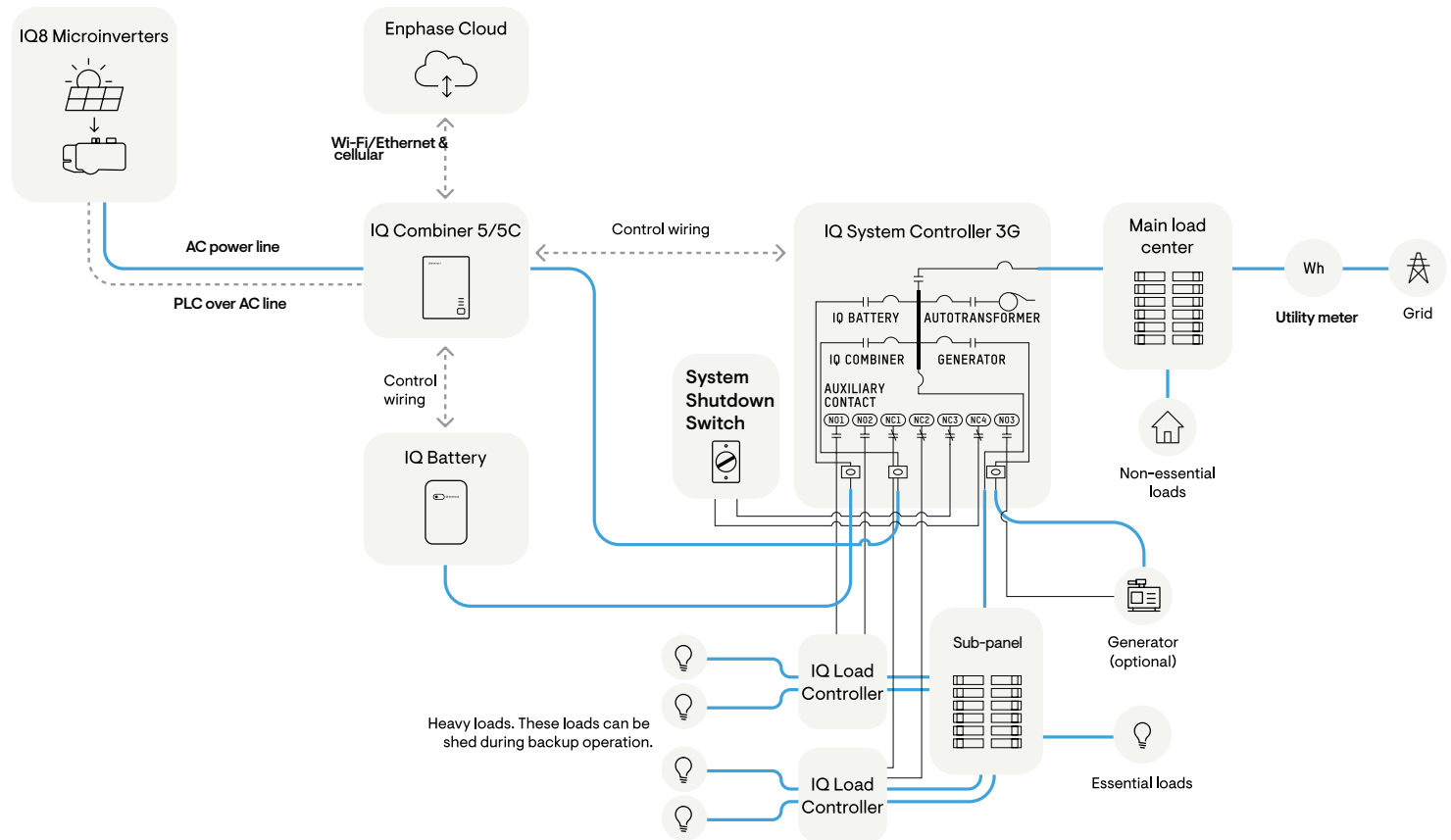

✓ **NOTE:** The System Shutdown Switch is not used for IQ6, IQ7, and M Series systems. Refer to the [Section C - Wiring](#) section for details.

This figure shows the system configuration. For wiring, follow the details in the wiring section.

Additional wiring and components are required when integrating generators. Refer to the Generator integration page for technical briefs and guides <https://enphase.com/installers/storage/generator>.

Scenario 3

Partial home backup with Sunlight Backup

This is the preferred configuration for partial home backup using only IQ8 PV, i.e., Sunlight Backup. IQ Battery can be integrated with IQ System Controller 3 based on the homeowner's needs.

It is recommended that installers use two IQ Load Controllers for load control to ensure seamless backup of essential loads using IQ8 Microinverters. At least one IQ Load Controller is required to successfully commission a Sunlight Backup system.

Do not install a Sunlight Backup system for a whole home backup scenario.

This configuration can only be supported with IQ8 Series Microinverters.

Check for [Compatibility](#).

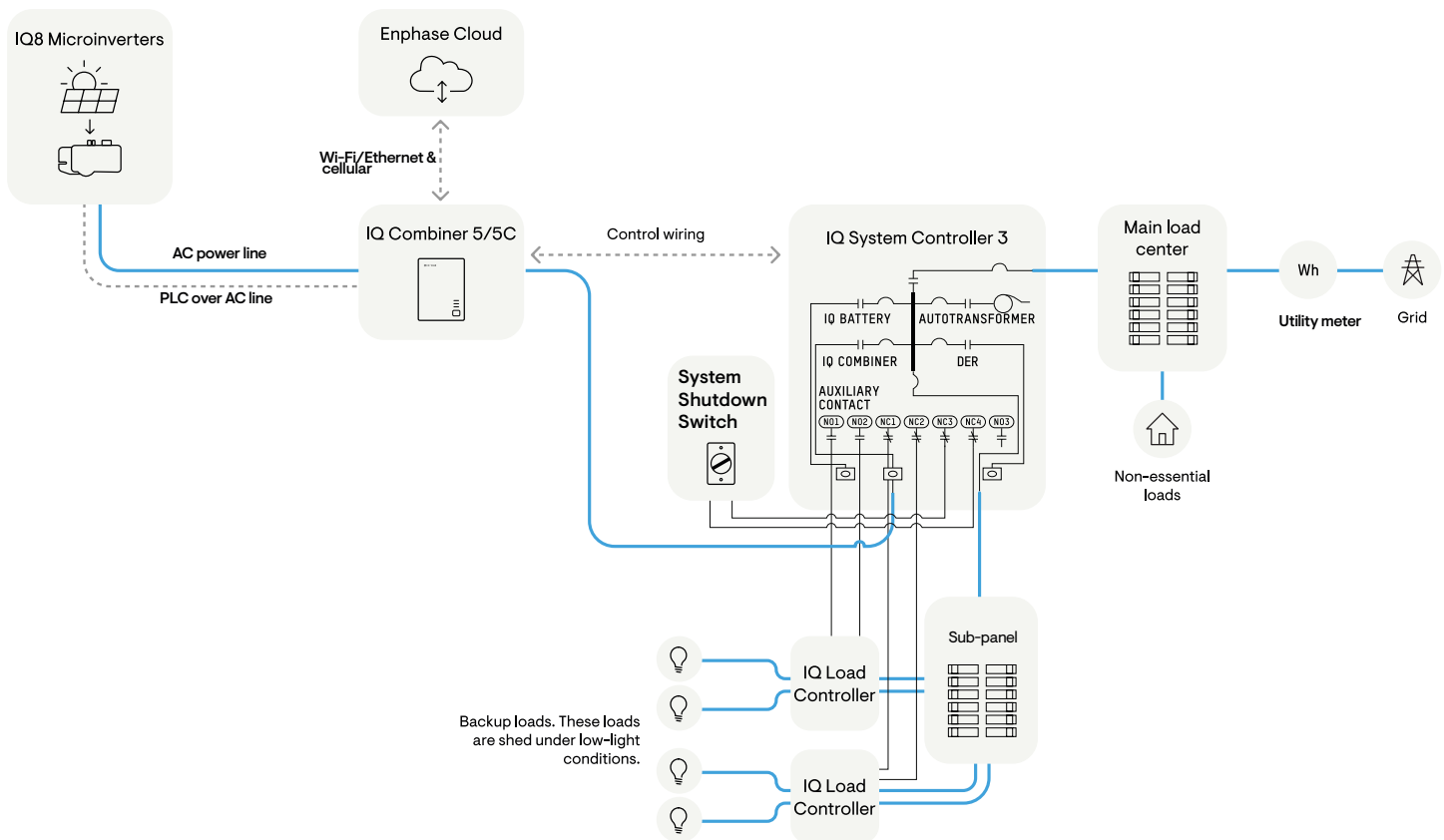

This figure shows the system configuration. For wiring, follow the details in the wiring section.

Scenario 3a

Partial home backup with Sunlight Backup and generator

This is the preferred configuration for partial home backup using only IQ8 PV, i.e., Sunlight Backup. A generator can be integrated with IQ System Controller 3G based on the homeowner's needs.

It is recommended that installers use two IQ Load Controllers for load control to ensure seamless backup of essential loads using IQ8 Series Microinverters. At least one IQ Load Controller is required to successfully commission a Sunlight Backup system.

Do not install a Sunlight Backup system for a whole home backup scenario.

This configuration can only be supported with IQ8 Series Microinverters.

Check for [Compatibility](#).

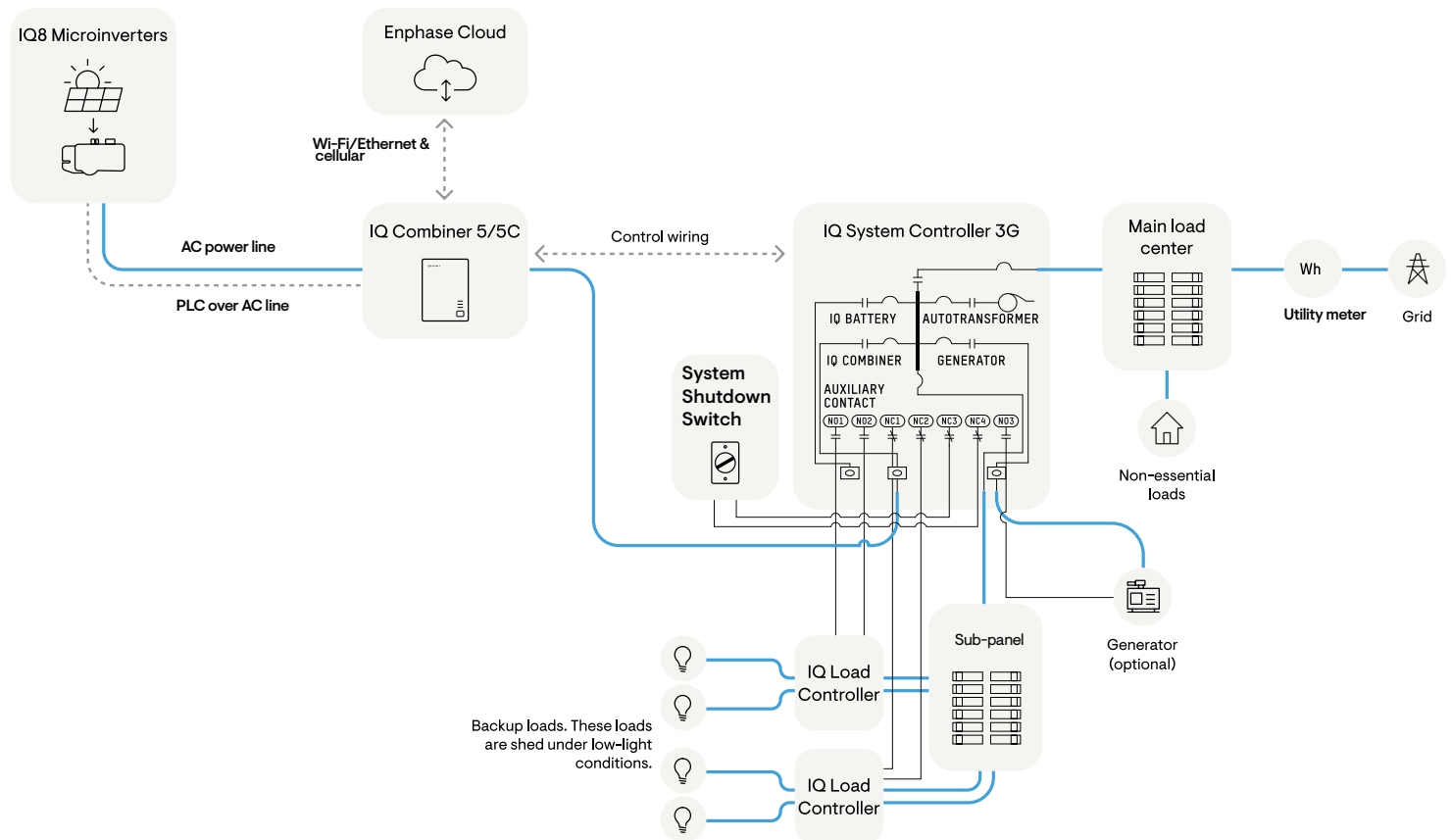

NOTE: The System Shutdown Switch is not used for IQ6, IQ7, and M Series systems. Refer to the [Section C - Wiring](#) section for details.

This figure shows the system configuration. For wiring, follow the details in the wiring section.

Additional wiring and components are required when integrating generators. Refer to the Generator integration page for technical briefs and guides <https://enphase.com/installers/storage/generator>.

Compatibility

Applicable for whole home backup and partial home backup (scenarios 1 and 2) with IQ Battery 5P

SYSTEM CONTROLLER	MICROINVERTER	COMBINER	LOAD CONTROLLER	COMMS-KIT-2 (CK2)	CONSUMPTION CT (CT-200-SPLIT OR CT-200-CLAMP)	BATTERY CT (CT-200-SPLIT OR CT-200-CLAMP)
IQ System Controller 3	IQ8/IQ7/IQ6 Series	IQ Combiner 5/5C	Recommended - one or two units	Included with Combiner	Two units are included with IQ Combiner 5/5C	One unit is included with IQ Combiner 5/5C
IQ System Controller 3	IQ8/IQ7/IQ6 Series	IQ Combiner 3-ES/3C-ES/4/4C	Recommended - one or two units	CK2	Two units are included with IQ Combiner 4/4C*	One unit is included with CK2
IQ System Controller 3	IQ8/IQ7/IQ6 Series	IQ Gateway	Recommended - one or two units	CK2	Must buy two units	One unit is included with CK2
IQ System Controller 3	M215/M250 Series	Envoy S Metered	Recommended - one or two units	CK2	Must buy two units	One unit is included with CK2

*For retrofits, purchase and install Consumption CTs if not present on site.

 **NOTE:** A hold-down kit is required with an IQ8 Series Microinverter for the breaker in all PV circuits.

Compatibility

Applicable for whole home backup and partial home backup (scenarios 1a and 2a)¹

SYSTEM CONTROLLER	MICROINVERTER	COMBINER	LOAD CONTROLLER	COMMS-KIT-02 (CK2)	CONSUMPTION CT (CT-200-SPLIT OR CT-200-CLAMP)	BATTERY CT (CT-200-SPLIT OR CT-200-CLAMP)	GENERATOR CT (CT-200-SPLIT OR CT-200-CLAMP)
IQ System Controller 3G	IQ8/IQ7/IQ6 Series	IQ Combiner 5/5C	Recommended - one or two units	Included with Combiner	Two units are included with IQ Combiner 5/5C	One unit is included with IQ Combiner 5/5C	Must buy an additional two units
IQ System Controller 3G	IQ8/IQ7/IQ6 Series	IQ Combiner 3-ES/3C-ES/4/4C	Recommended - one or two units	CK2	Two units are included with IQ Combiner 4/4C*	One unit is included with CK2	Must buy an additional two units
IQ System Controller 3G	IQ8/IQ7/IQ6 Series	IQ Gateway	Recommended - one or two units	CK2	Must buy two units	One unit is included with CK2	Must buy an additional two units
IQ System Controller 3G	M215/M250 Series	Envoy S Metered	Recommended - one or two units	CK2	Must buy two units	One unit is included with CK2	Must buy an additional two units

1. IQ Battery 5P with generator support.

*For retrofits, purchase and install 0 Consumption CTs if not present on site.

 **NOTE:** A hold-down kit is required with an IQ8 Series Microinverter for the breaker in all PV circuits.

Compatibility

Applicable for Sunlight Backup (scenario 3)

SYSTEM CONTROLLER	MICROINVERTER	COMBINER/ GATEWAY	LOAD CONTROLLER	COMMS KIT 2 (CK2)	CONSUMPTION CT (CT-200-SPLIT OR CT-200-CLAMP)
IQ System Controller 3	IQ8 Series	IQ Combiner 5/5C	Must have one or two units	Included with Combiner	Two units are included with IQ Combiner 5/5C
IQ System Controller 3	IQ8 Series	IQ Combiner 3-ES/3C-ES/4/4C	Must have one or two units	CK2	Two units are included with IQ Combiner 4/4C*, and one unit is included with CK2
IQ System Controller 3	IQ8 Series	IQ Gateway	Must have one or two units	CK2	One unit is included with CK2**

* For retrofits, purchase and install Consumption CTs if not present on site.

** Must buy one Consumption CT unit.

☑ **NOTE:** A hold-down kit is required with an IQ8 Series Microinverter for the breaker in all PV circuits.

Applicable for sunlight backup with generator (scenario 3a)

SYSTEM CONTROLLER	MICROINVERTER	COMBINER/ GATEWAY	LOAD CONTROLLER	COMMS KIT 2 (CK2)	CONSUMPTION CT (CT-200-SPLIT OR CT-200-CLAMP)	GENERATOR CT (CT-200-SPLIT OR CT-200-CLAMP)
IQ System Controller 3G	IQ8 Series	IQ Combiner 5/5C	Must have one or two units	Included with Combiner	Two units are included with IQ Combiner 5/5C	Must buy an additional two units
IQ System Controller 3G	IQ8 Series	IQ Combiner 3-ES/3C-ES/4/4C	Must have one or two units	CK2	Two units are included with IQ Combiner 4/4C*	Must buy an additional two units
IQ System Controller 3G	IQ8 Series	IQ Gateway	Must have one or two units	CK2	One unit is included with CK2**	Must buy an additional two units

* For retrofits, purchase and install Consumption CTs if not present on site.

** Must buy one Consumption CT unit.

☑ **NOTE:** A hold-down kit is required with an IQ8 Series Microinverter for the breaker in all PV circuits.

Specifications

Electrical specifications

DESCRIPTION	VALUE
Nominal voltage/Range (L-L)	240 VAC/(192 V–288 V)
Nominal frequency/Range	60 Hz/56–63 Hz
Frequency measurement accuracy	±0.1 Hz
Maximum continuous current rating	160 A
Maximum input overcurrent protection device	200 A
Maximum output overcurrent protection device	200 A
Maximum overcurrent protection device rating for generator circuit	80 A (IQ System Controller 3G only - SC200G111C240US01)
Maximum overcurrent protection device rating for storage circuit	2 × 80 A (IQ System Controller 3 - SC200D111C240US01), 1 × 80 A (IQ System Controller 3G - SC200G111C240US01)
Maximum overcurrent protection device rating for PV combiner unit	80 A
Internal busbar rating	200 A
Maximum input short circuit current	22 kA

Utility interconnection voltage and frequency trip limits and trip times

TRIP POINT	DEFAULT SETTINGS	
	SETTING	TRIP TIME
Fast OverVoltage	288 V L-L 144 V L-N	0.160 s
Slow OverVoltage	264 V L-L 132 V L-N	13 s
Slow UnderVoltage	211.2 V L-L 105.6 V L-N	21 s
Fast UnderVoltage	120 V L-L 60 V L-N	2 s
OverFrequency	60.5 Hz	0.160 s
UnderFrequency	59.3 Hz	0.160 s

DESCRIPTION	VALUE
Output power derating with operating ambient temperature	No derating
Neutral-forming transformer (NFT)	
Breaker rating (pre-installed)	40 A between L1 and Neutral; 40 A between L2 and Neutral
Continuous rated power	3,600 VA
Maximum continuous unbalance current	30 A @ 120 V
Peak unbalanced current	80 A @ 120 V for two seconds

Mechanical specifications

DESCRIPTION	VALUE
Dimensions (WxHxD)	50 cm × 91.6 cm × 24.6 cm (19.7 in × 36 in × 9.7 in)
Weight	39.4 kg (87 lb)
Normal operation temperature range	-40°C to 50°C (-40°F to 122°F)
Maximum altitude	2,500 m (8,200 ft)
Enclosure type	3R or rainproof

For conduit hubs, use only UL Listed raintight or wet location hubs of type 3R for entry into the enclosure.

What is in the box

IQ System Controller 3/3G

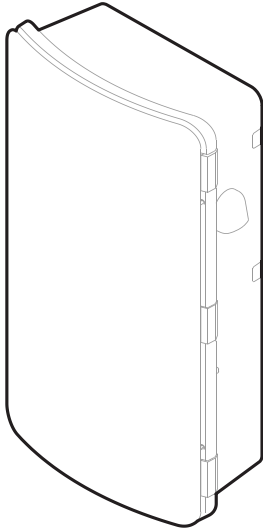

Wall-mounting bracket

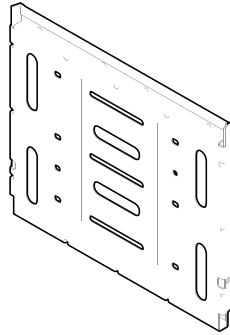

System Shutdown Switch

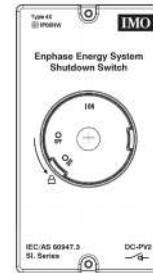

Comes pre-wired with 4 x 20 ft. color-coded wires.

Accessory kit

ITEM NAME	ITEM CATEGORY	DESCRIPTION	QUANTITY
Filler Cover Mounting BKT-L 200G Enpower	Plastic part	Filler Cover Mounting BKT-L 200G	2
Filler Cover Mounting BKT-R 200G Enpower	Plastic part	Filler Cover Mounting BKT-R 200G	2
Screw, Pan Hd, Phillips #3, M6 x 25 mm Lg (5 mm Shank - 20 mm Thread), Machine, 304 SS	Fastener	Screw, Pan Hd, Phillips #3, M6 x 25 mm Lg (5 mm Shank - 20 mm Thread), Machine, 304 SS	2
Screw, Pan Hd, Torx X20, Machine, #8-32 UNC, 0.63" Lg, A2-70	Fastener	Screw, Pan Hd, Torx X20, Machine, #8-32 UNC, 0.63" Lg, A2-70	1
Lit Kit Label, Enpower 200G	Label	Lit Kit Label, IQ System Controller 200G	1
Label, Enpower, CT Field	Label	—	6
Label, Enpower, PCS Field	Label	—	2
Feed-through header with Cable Assy Header Enpower 200G R2	Cable assembly	System Shutdown feed-through header with cable assembly	1
NEC Labels for Rapid Shutdown	Label	Labels required as per NEC for Rapid Shutdown	2
Control header with resistor	Spare part	Spare Control header with resistor for control wiring installation	1

Tools/additional items required

S. NO	ITEM NAME	QUANTITY	SOURCE
1	CT-200-CLAMP or CT-200-SPLIT	3*	IQ Combiner/Enphase Store
2	EP200G-HNDL-R1 (lifting handle)	1	Enphase Store
3	Breakers, different ratings	4	Enphase Store/retail outlets
4	Conduits (with fittings and fitting tools)	As required	Provided by installer
5	Drill	1	Provided by installer
6	5/32" pilot bit	1	Provided by installer
7	Screwdriver	1	Provided by installer
8	Wrench	1	Provided by installer
9	Adjustable wrench	1	Provided by installer
10	Torque wrench	1	Provided by installer
11	Level	1	Provided by installer
12	5/32" Allen key	1	Provided by installer
13	Conductor stripper	1	Provided by installer
14	Electrician's hole saw (2") or punch set	1	Provided by installer
15	Stud finder (if required)	1	Provided by installer
16	Conduit ground hub rings	1	Provided by installer
17	#10,1/4" or 5/16" lag bolts or screw 3" long (depending on attaching wall) for each wall-mount bracket	As required	Provided by installer
18	Control wire	As required	Distribution/Enphase Store**

* Additional two current transformers (CTs) are required with IQ System Controller 3G (generator support)

** Enphase SKU for control cable: CTRL-SC3-NA-01

 **WARNING:** Do not use power tools for electrical connections.

Section A

Mounting the product

Plan a location for the IQ System Controller



- IQ System Controller is NEMA type 3R rated and can be mounted indoors and outdoors.¹
- Install this product where cables from the PV/IQ Combiner, grid, and IQ Battery are easily accessible and can be terminated at the IQ System Controller.



- This product is designed to be installed on a vertical wall only. Do not install this product flat on the ground.
- The mounting surface must be able to support 87 lb.
- Follow all local standards and regulations during installation.



- The product operates within an ambient temperature range from -40°C to 50°C (-40°F to 122°F).
- Do not install the product in a place exposed to direct sunlight throughout the day².
- Do not install the product in a very dusty environment.



- This product must not be installed at altitudes above 8,200 ft (2,500 m).



- In flood-prone areas, ensure that the clearance from the ground is sufficient to avoid water ingress.

¹ The enclosure is indoor or outdoor rated and designated to withstand exposure to moisture, rainfall, and harsh environmental conditions. It is not recommended to install the unit directly under any downspouts, faucets, or similar water sources.

² It is safe to install the IQ System Controller in direct sunlight. The product is designed to operate at an ambient temperature of -40°C to 50°C, even under direct sunlight. Extended exposure to direct sunlight in higher ambient temperature conditions may cause the internal breakers to trip when operating at full load.

Section A - Mounting the product

Step 1: Minimum clearance

This product must be installed with clearance at the left, right, top, bottom, and front of the product, as shown in the figure.

Follow all local standards and regulations related to mounting an IQ System Controller.

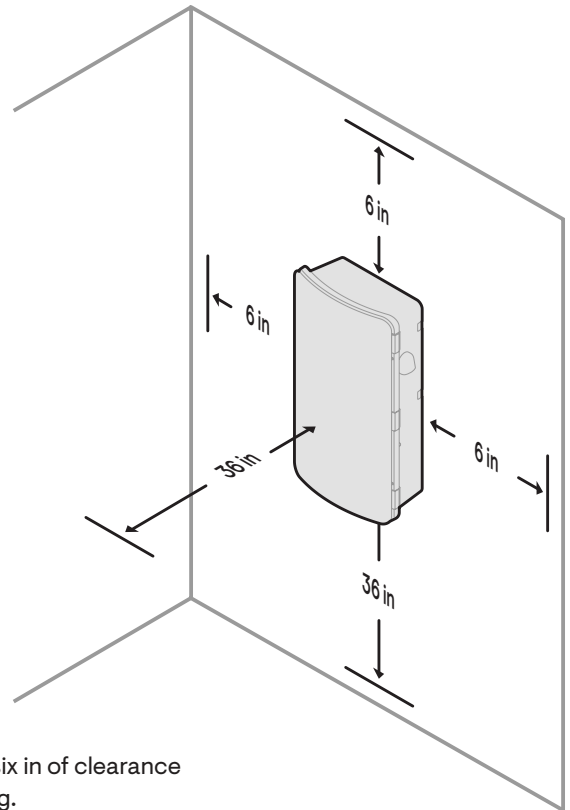
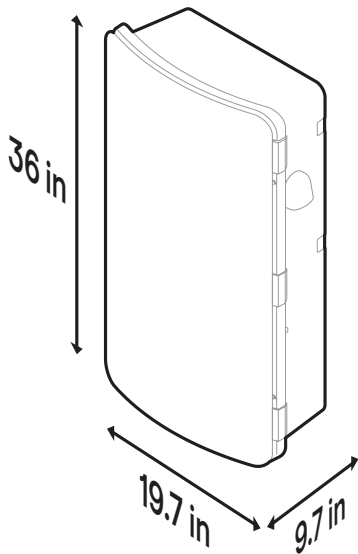

⊙ **NOTE:** If installed indoors, the IQ System Controller 3/3G requires at least six in of clearance from the floor. Follow all local standards and regulations related to mounting.

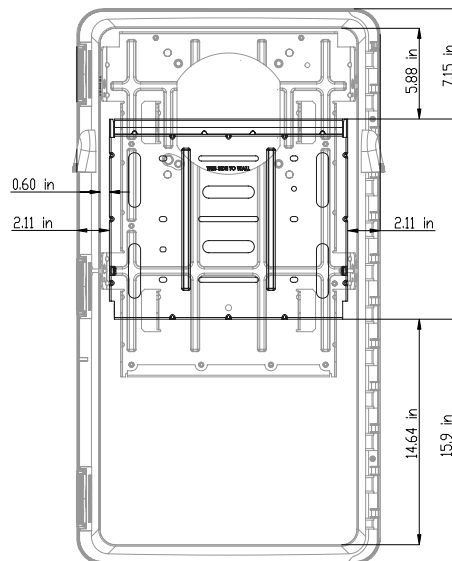
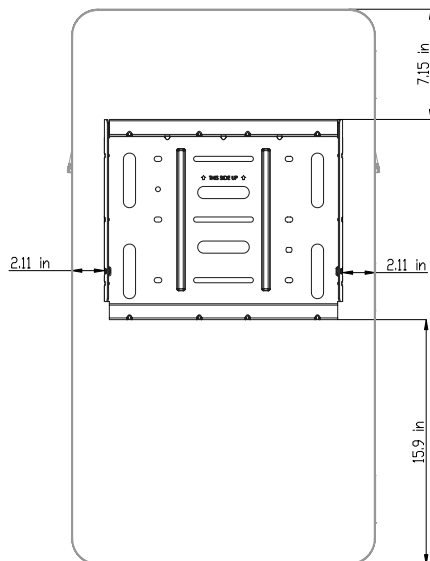

Section A - Mounting the product

Step 2:

Install the mounting bracket

Install the mounting bracket and mount the IQ System Controller as per the following instructions:

- Use 3" long wood screw #10, 1/4", or 5/16" (depending on the attachment wall) or masonry attachments if installed in masonry to attach the IQ System Controller bracket. Use one screw and washer for each slot. The slot size of the IQ System Controller wall mount bracket is 8.5 mm.
- Check with a structural engineer and local standards for local requirements. Use an appropriately sized washer for each of the screws.
- The IQ System Controller weighs 39.4 kg (87 lb) and will require two people to lift the unit.
- Risk of injury and equipment damage. Avoid dropping the IQ System Controller. Doing so may create a hazard, cause serious injury, and/or damage the equipment.
- Risk of injury and equipment damage. Do not release the IQ System Controller until you ensure that the IQ System Controller is fully seated in the wall-mount bracket shelf.

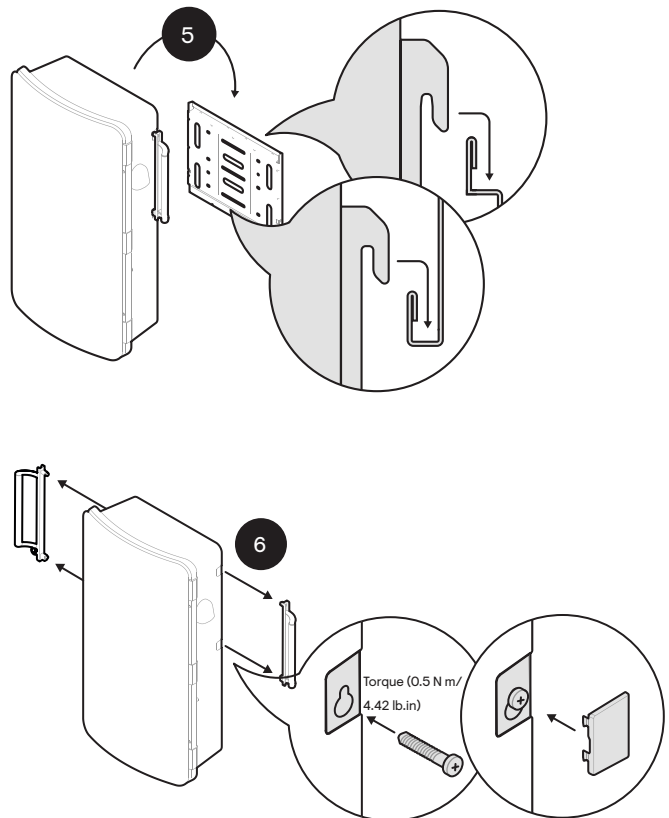
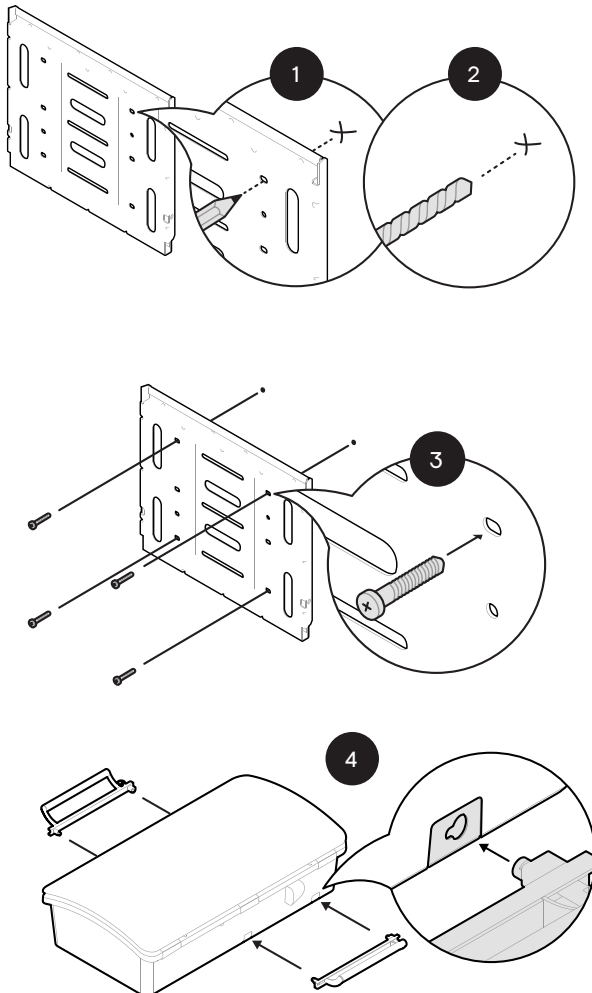

Provided in the accessory kit

Section A - Mounting the product

Step 3:

Remove the door

- Pinch the lock pin on the top hinge section.
- Lift the door upside down to remove it.

⚠ WARNING: Equipment damage if a recommended practice is not followed.
Risk of equipment damage. Do not wire the IQ System Controller when it is energized.

Open the dead front

Before removing the dead front, ensure the IQ System Controller is completely de-energized.

⚠ Risk of equipment damage. Do not remove the pre-installed solar shield attached to the enclosure door.

- Risk of equipment damage. Do not wire the IQ System Controller when it is energized.
- Risk of electric shock. Do not modify the dead front other than to remove or replace filler plates, as needed. The product warranty can be affected by modification.

1

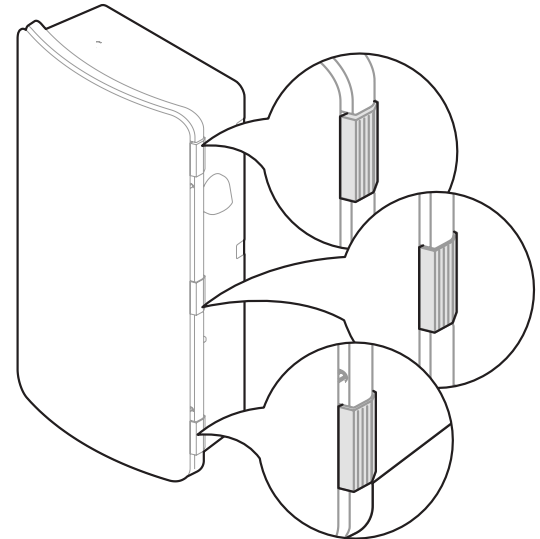

3

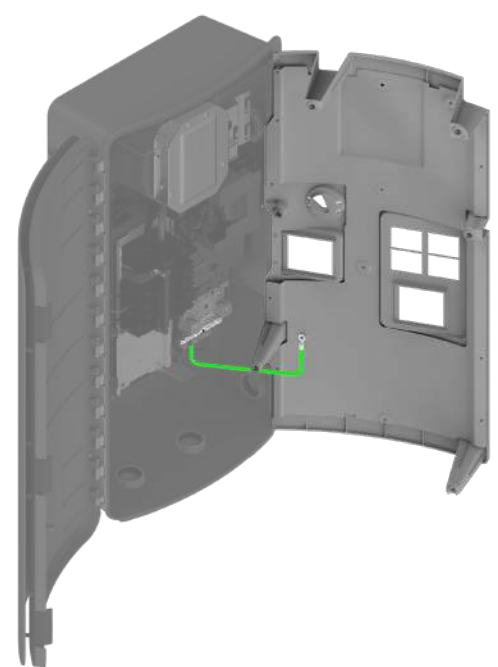

2

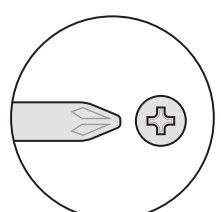
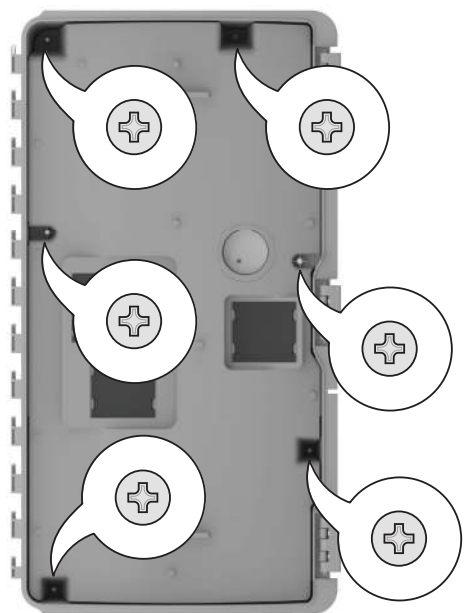

Phillips screw #2

The ground connection to the dead front needs to be carefully disconnected before the dead front can be dismantled from the IQ System Controller.

Section B

Mounting the breakers

Internal view of IQ System Controller 3/3G

The following figure shows the IQ System Controller 3/3G after the dead front is removed. It comes with an inbuilt neutral forming transformer, microgrid interconnection device, automatic transfer switch, and a panel board to mount plug-in type breakers.

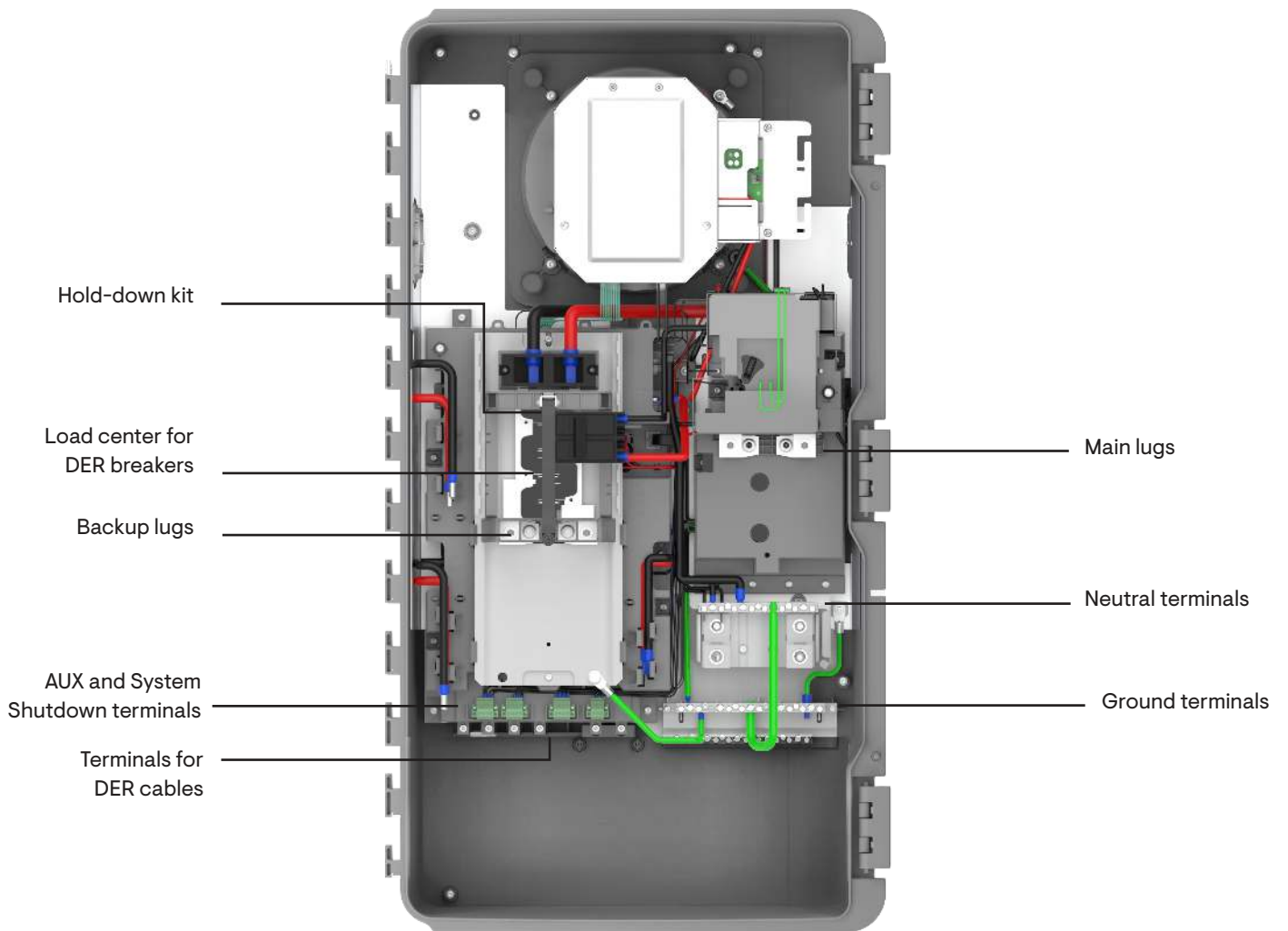

Section B - Mounting the breakers

Wiring for service entrance

If the IQ System Controller is used as service entrance equipment:

- Do not remove the green-colored system bonding jumper.
- Paste labels provided in the accessory kit.

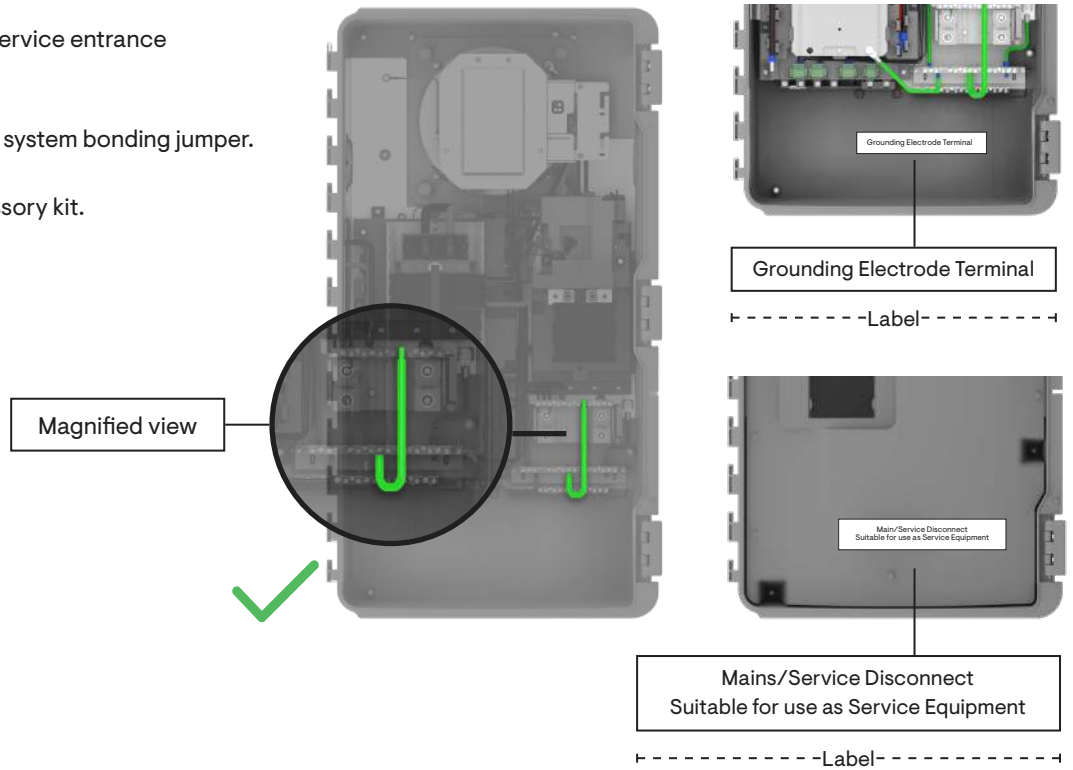

If the IQ System Controller is NOT used as a service entrance equipment:

- Remove the system bonding jumper wire.

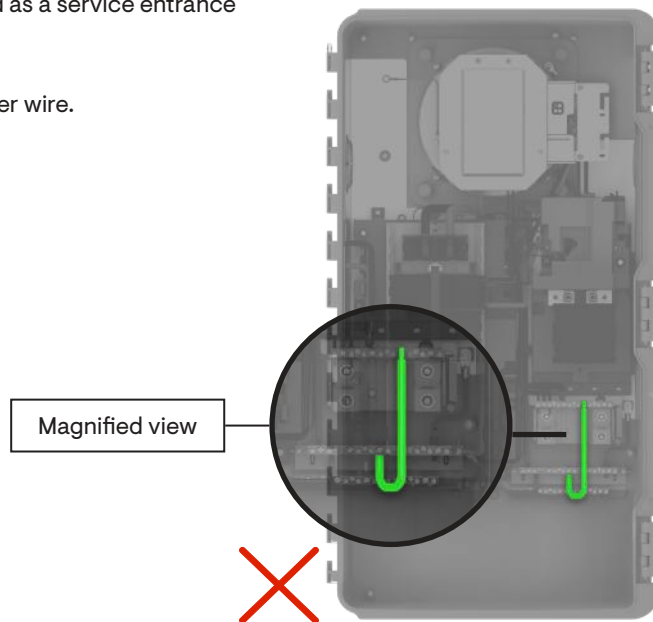

Section B - Mounting the breakers

Install mains and backup breakers

If breakers are being installed for mains and backup connections, the lugs should be removed, and the breakers should be installed.

Only Eaton CSR range breakers with ratings between 100 A and 200 A can be used for the mains and backup connections.

⚠ WARNING: Risk of equipment damage. Do not wire the IQ System Controller when it is energized.

ENPHASE BREAKER SKU	EATON BREAKER PART
BRK-100A-2P-240V	CSR2100N
BRK-125A-2P-240V	CSR2125N
BRK-150A-2P-240V	CSR2150N
BRK-175A-2P-240V	CSR2175N
BRK-200A-2P-240V	CSR2200N

Backup connection

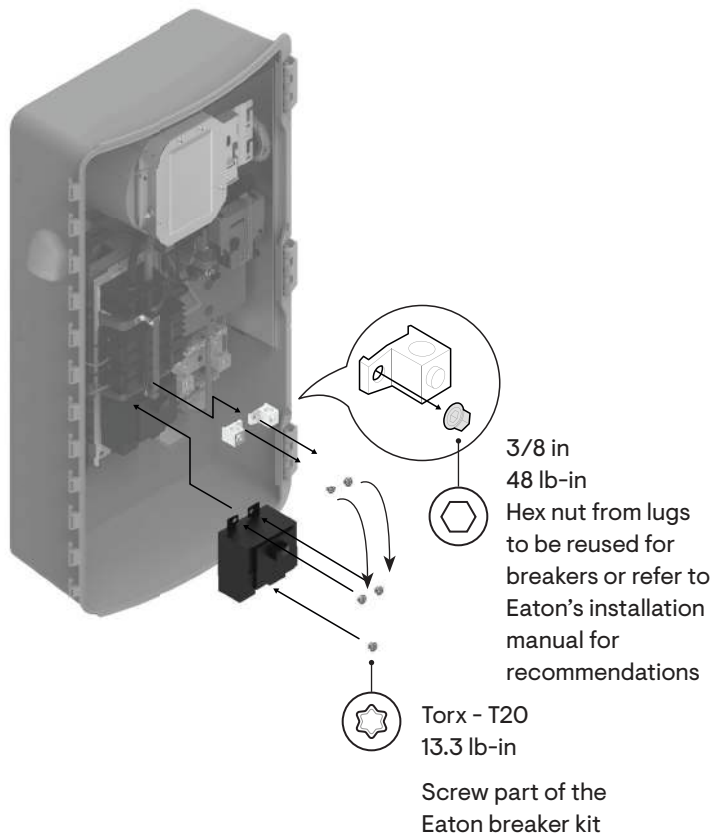

Mains connection

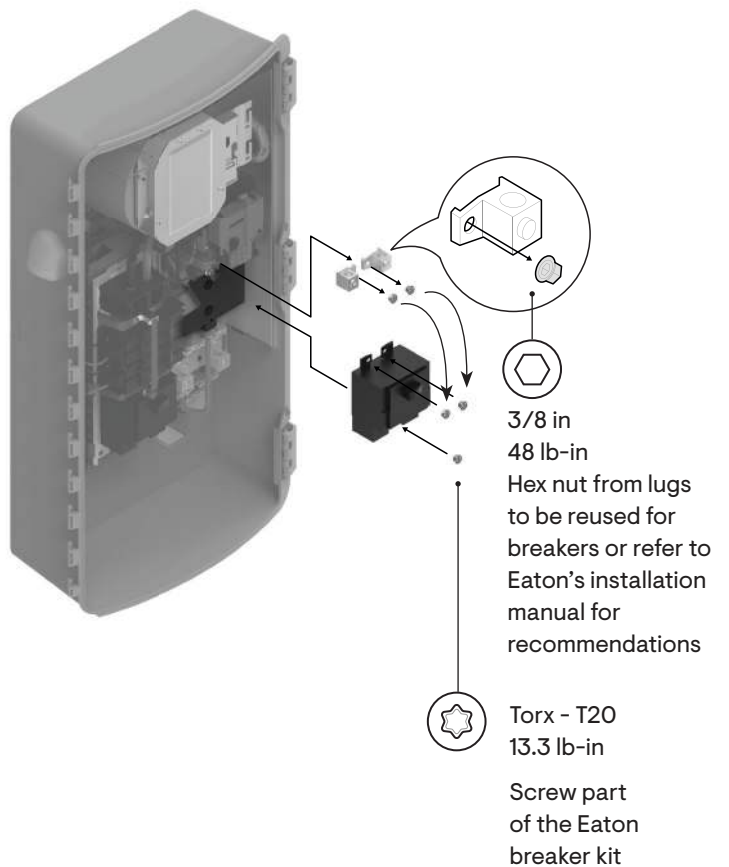

⚠ WARNING: Tighten the Hex nut (⊙) and recheck the torque before every wire installation.

Section B - Mounting the breakers

Breakers for IQ8 Systems without generator

The IQ System Controller 3 comes pre-installed with a quad breaker for the neutral forming transformer (NFT) and IQ Gateway.

The hold-down kit for the breakers is factory-installed in the IQ System Controller 3. Loosen the screw (use Phillips head screwdriver #1) and pull the hold-down kit arm up to install the breakers. After the breaker installation, pull down the hold-down kit arm and tighten the screw with torque 5.3 lb-in (0.6 N m).

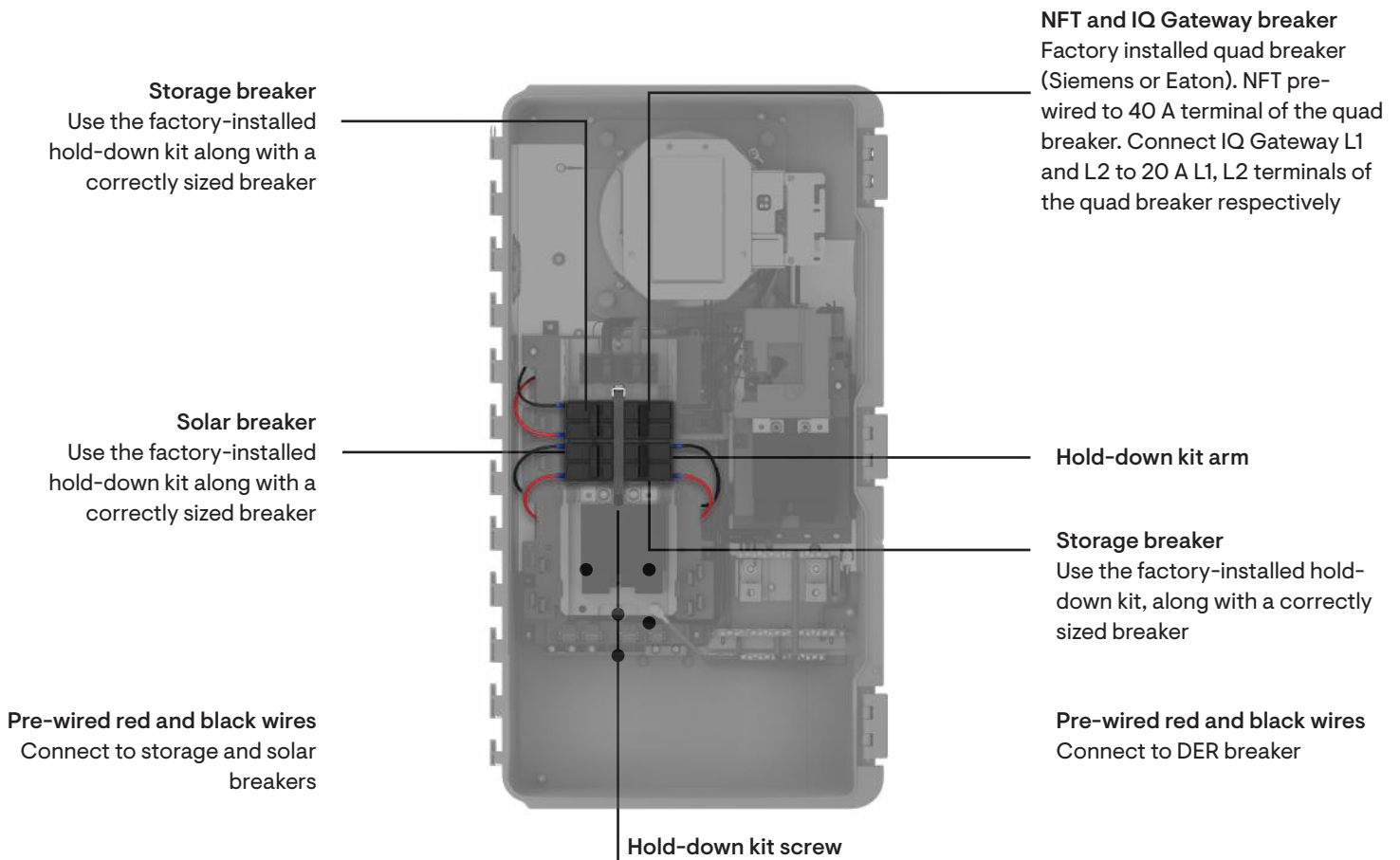

ENPHASE BREAKER PART	EATON BREAKER PART	TORQUE
BRK-20A-2P-240V	BR220	27 lb-in
BRK-40A-2P-240V	BR240	
BRK-60A-2P-240V	BR260	
BRK-80A-2P-240V	BR280	
BRK-20A40A-4P-240V	BQC220240	

The following alternate breakers are approved for use in the load center:

MANUFACTURER	MODEL SERIES	CURRENT RATING
GE/ABB	THQL21xx	20/40/60/80 A
Siemens	Q2xx	20/40/60/80 A
Siemens (quad breaker)	Q24020CT2	20/40 A

Refer to the breaker manufacturer's manual for torque values.

Section B - Mounting the breakers

Breakers for IQ8 Systems with generator

IQ System Controller 3G allows for generator integration with the Enphase Energy Systems. The breaker on the bottom right slot of the panel board can be sized and used to integrate the generator.

For generator control and power line schematics, refer to the [Section C - Wiring](#).

The hold-down kit for the breakers is factory-installed in the IQ System Controller 3G. Loosen the screw (use Phillips head screwdriver #1) and pull the hold-down kit arm up, to install the breakers. After the breaker installation, pull down the hold-down kit arm and tighten the screw with torque 5.3 lb-in (0.6 N m).

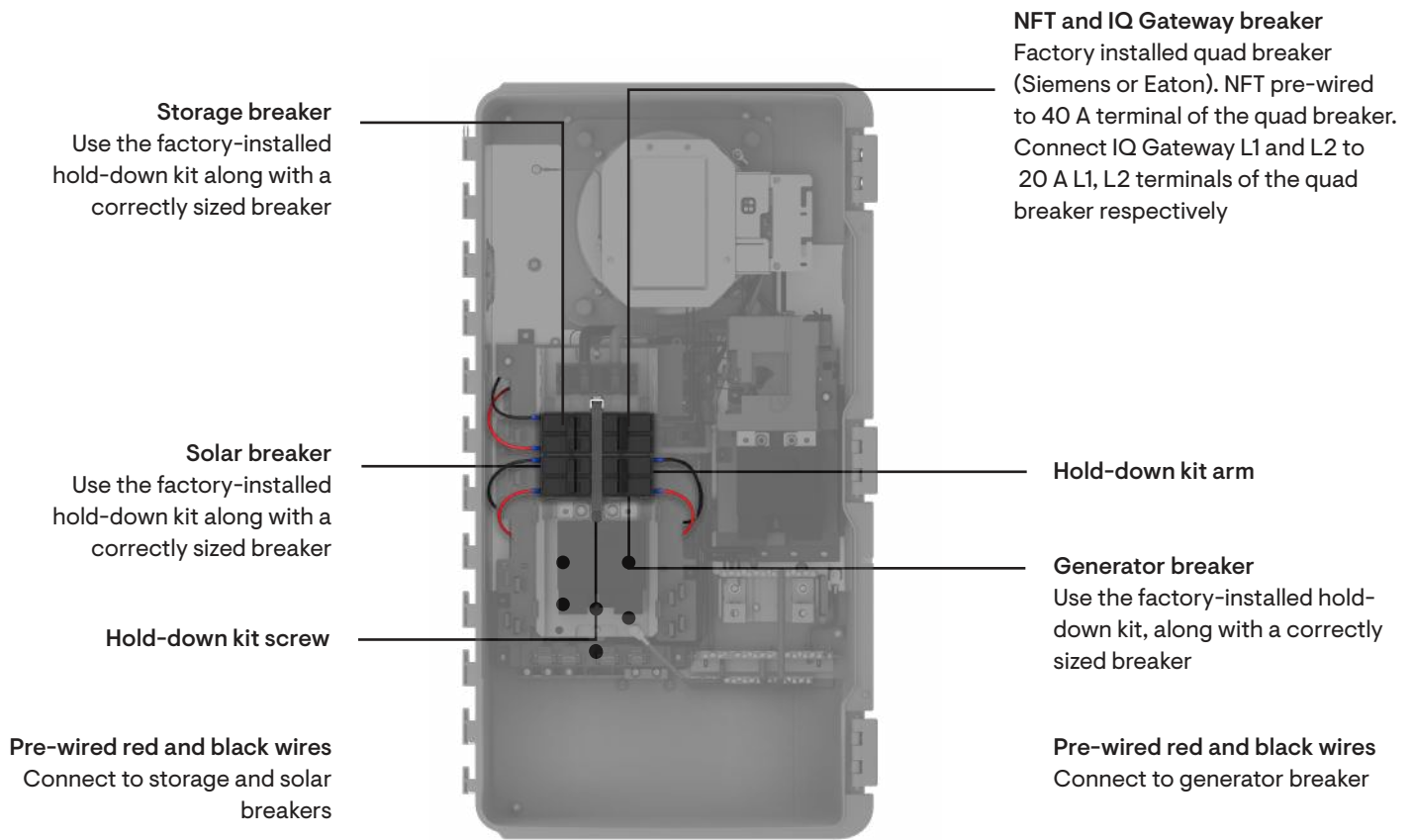

ENPHASE BREAKER PART	BREAKER PART	TORQUE
BRK-20A-2P-240V	BR220	27 lb-in
BRK-40A-2P-240V	BR240	
BRK-60A-2P-240V	BR260	
BRK-80A-2P-240V	BR280	
BRK-20A40A-4P-240V	BQC220240	

The following alternate breakers are approved for use in the load center:

MANUFACTURER	MODEL SERIES	CURRENT RATING
GE/ABB	THQL21xx	20/40/60/80 A
Siemens	Q2xx	20/40/60/80 A
Siemens (quad breaker)	Q24020CT2	20/40 A

Refer to the breaker manufacturer's manual for torque values.

Section B - Mounting the breakers

Breaker for NFT and IQ Gateway

The IQ System Controller 3 comes pre-installed with a quad breaker (Siemens or Eaton) for the neutral forming transformer (NFT) and IQ Gateway.

NFT pre-wired to 40 A terminal of the quad breaker. Connect IQ Gateway L1 and L2 to the 20 A L1 and L2 terminals of the quad breaker, respectively.

NOTE: The cable used to connect IQ Gateway power terminals to the quad breaker must adhere to local electrical codes.

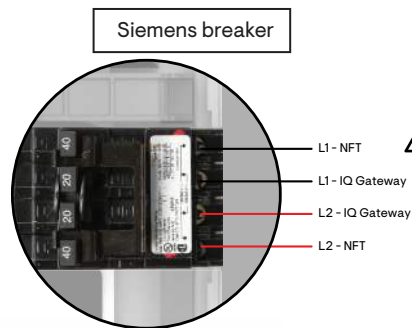

WARNING: IQ System Controller with 8 AWG wires on NFT L1 and L2 can be used with either the Eaton or Siemens quad breaker. IQ system controller with 6 AWG wires on NFT L2 can be used with only the Eaton quad breaker.

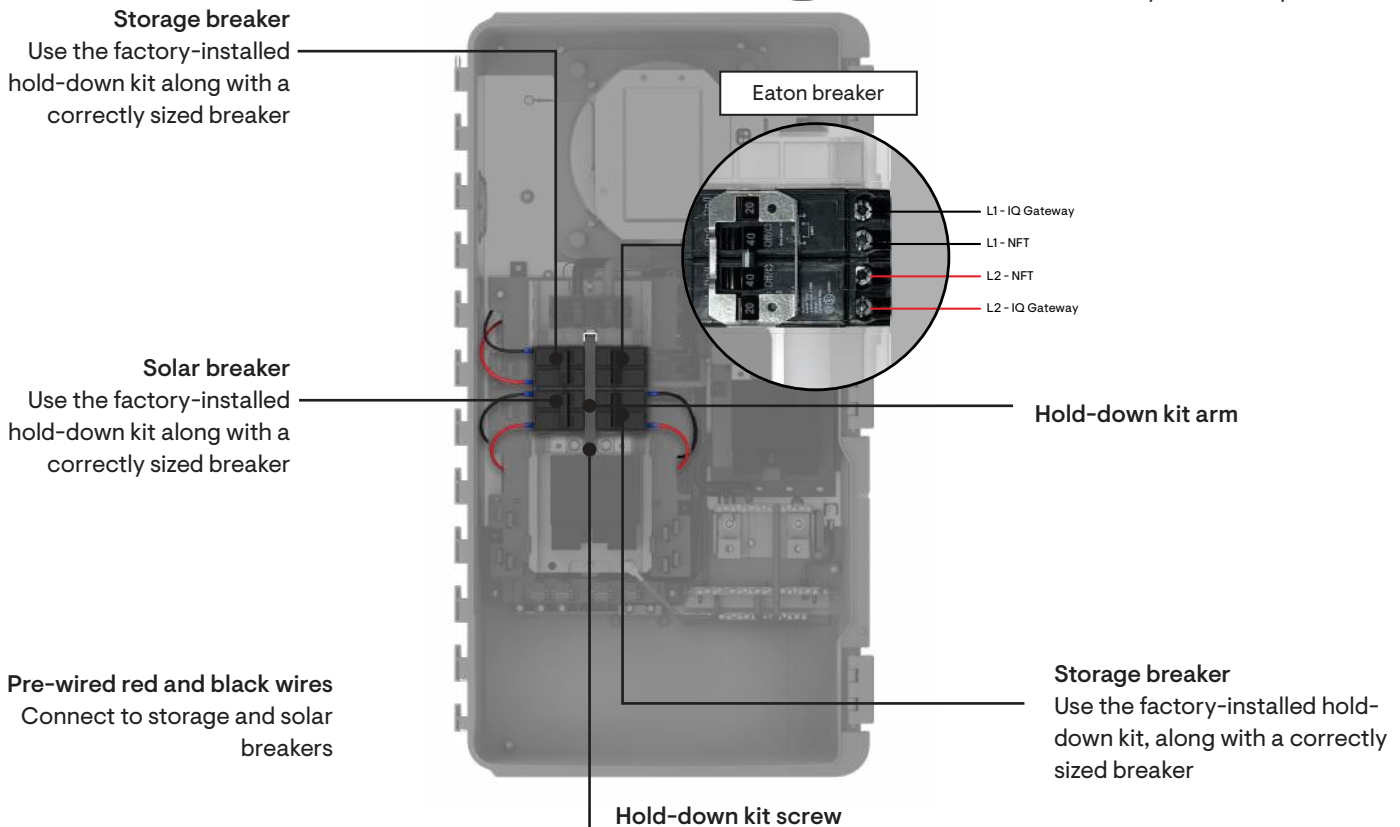

ENPHASE BREAKER PART	EATON BREAKER PART	TORQUE
BRK-20A-2P-240V	BR220	27 lb-in
BRK-40A-2P-240V	BR240	
BRK-60A-2P-240V	BR260	
BRK-80A-2P-240V	BR280	
BRK-20A40A-4P-240V	BQC220240	

The following alternate breakers are approved for use in the load center:

MANUFACTURER	MODEL SERIES	CURRENT RATING
GE/ABB	THQL21xx	20/40/60/80 A
Siemens	Q2xx	20/40/60/80 A
Siemens (quad breaker)	Q24020CT2	20/40 A

Section C

Wiring

Drill conduits

Drill conduit entry holes as needed and install conduit grounding lugs for each opening. Be sure to reseal unused conduit entry holes with sealing plugs.

Mains supply conductors should enter the IQ System Controller from the bottom or bottom-left side.

Backup load conductors should enter the IQ System Controller from the bottom or bottom-right side.

IQ Battery, IQ Combiner, and generator conductors should enter from the bottom, bottom-left, or bottom-right sides.

Size the conductors (line, neutral, and ground) depending on the service or breaker rating and voltage rise requirements according to local codes.

Refer to the conductor rating table on the door of the IQ System Controller.

Recommended conduit drill locations*

CONDUIT LOCATION	MAINS	BACKUP LOADS	DER
Bottom	✓	✓	✓
Left wall	✓	–	✓
Right wall	–	✓	✓

* The recommendation is applicable for 200 A-rated wire with a bending radius as per NEC codes.

⊗ **NOTE:** DO NOT drill on the rear wall of the IQ System Controller for conduit entry.

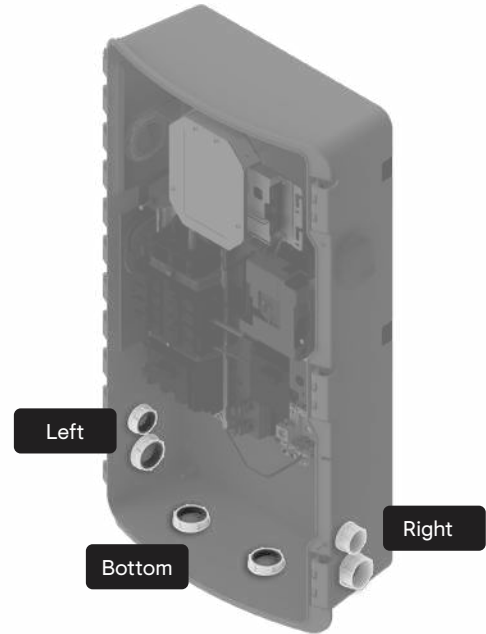

Section C - Wiring

DER wiring

Connect the DER (IQ Battery, IQ Combiner/Solar, and generator) wires to the lugs at the bottom, as indicated in the following images.

Refer to the wiring table and torque recommendation before connecting the wires. Refer to local codes for any specific local requirements.

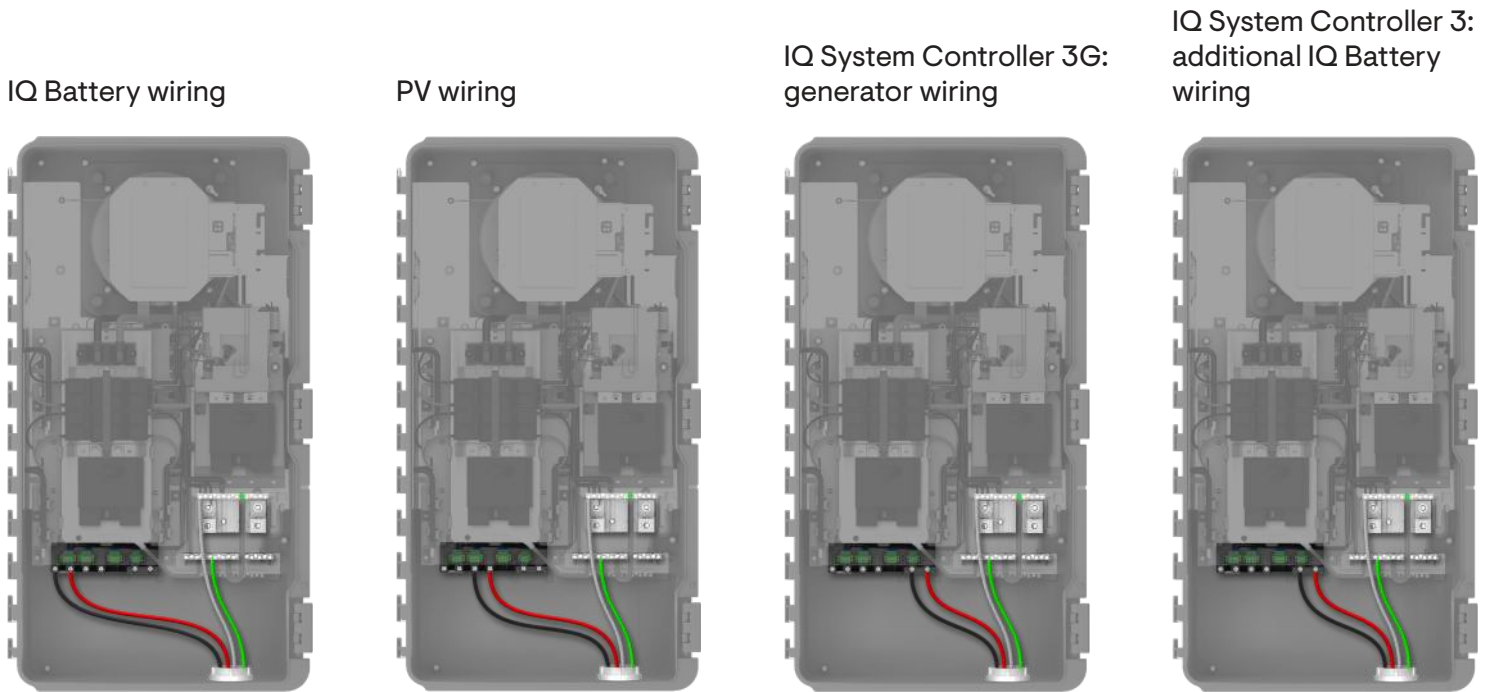

WARNING: Use only high-quality machined (milled) hex form bit with 0.2+ in (5+ mm) length and 0.139 in (3.53 mm) minimum across hex points.



PV/IQ Battery/Generator connections

AWG	TORQUE (lb-in)
14-10	25
8	30
4-6	35
2-3	40

NEUTRAL AND GROUND CONNECTIONS	AWG	TORQUE (LB.IN)	
Neutral and ground bar – large holes	1/0-3	50	–
	4-6	45	⊘
	8	40	5/16"-24 UNF
Neutral and ground bar – small holes	10-14	35	–
	6-8	25	⊘
Neutral lugs	10-14	15	#10-32 UNF
	300 kcmil-6	275	⊘ 3/8"

NOTE: The ground bar doesn't support cables higher than 1/0 to be compliant with the bending radius as per the standards.

Section C - Wiring

Aux wiring: System Shutdown Switch

Enphase System Shutdown (SSD) Switch wiring (compliance requirement)

The IQ System Controller meets UL1741 PV RSE and NEC Rapid Shutdown requirements for IQ8 Microinverters. The System Shutdown Switch is the rapid shutdown initiator. The System Shutdown Switch ensures a single point of initiation per NEC 2020. The System Shutdown Switch, when turned off, also disconnects the battery from the system.

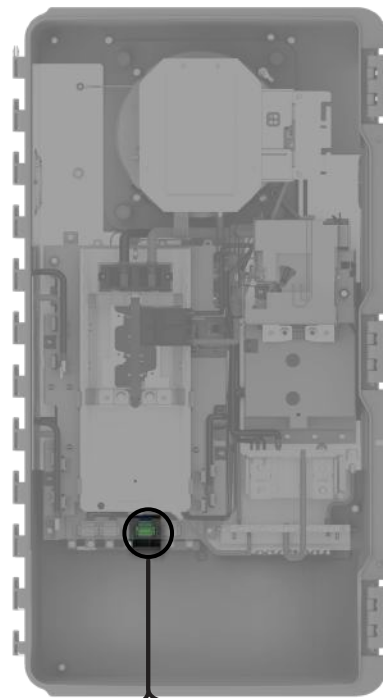

Wiring for systems with IQ8 Series Microinverters

Wiring for systems with non-IQ8 Series Microinverters

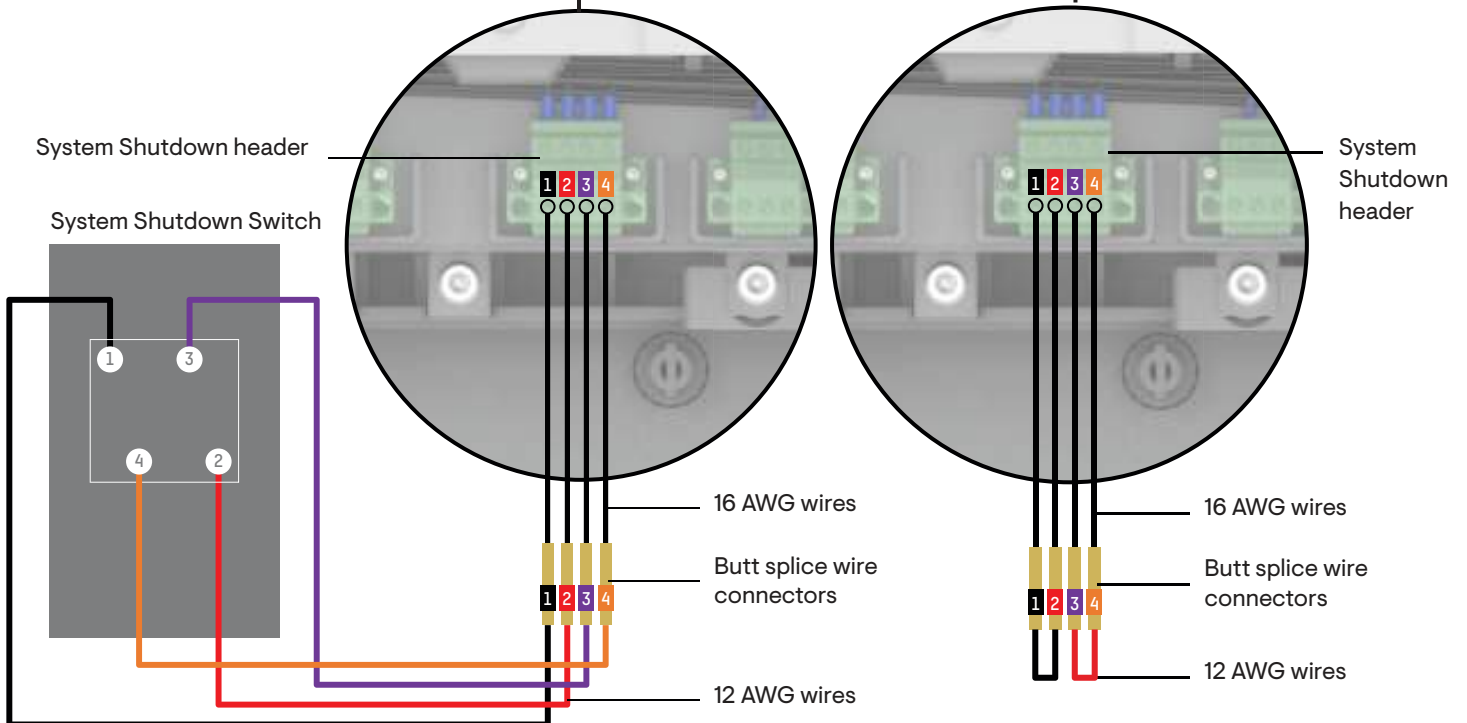

- ✓ NOTE: Control lines to headers support 28 AWG and 16 AWG wire gauges.
- ✓ NOTE: Do not use cables more than 20 ft long for connections between System Shutdown Switch and System Shutdown header.
- ✓ NOTE: Make sure to keep the butt splice connectors inside the enclosure and avoid leaving them hanging outside.

Section C - Wiring

Aux wiring: System Shutdown Switch

✓ **NOTE:** An improved SSD header kit allows for the co-location of SSD wiring and AC power conductors in a single conduit, eliminating the need for separate conduits.

⚠ **WARNING:** To prevent water ingress, do not use the top conduit entry on System Shutdown Switch.



Section C - Wiring

Aux wiring: System Shutdown Switch

IQ System Controller 3/3G units may get stuck in a System Shutdown or rapid shutdown state, preventing system provisioning. Either follow the wiring tests for the SSD Switch in the ON position or the wiring tests for the SSD Switch in the OFF position.

Wiring test for SSD Switch in the ON position

- a. Ensure the SSD Switch is in the ON position.



- b. Set the multimeter to test for continuity.

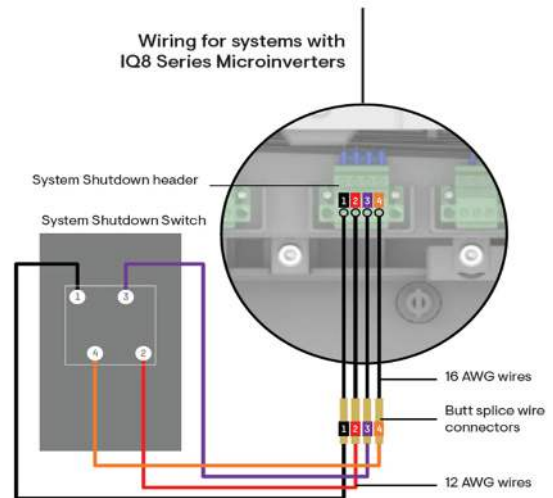

- c. Measure the terminal test points:
- 1 and 2 at the SSD Switch
 - 1 and 2 at the SSD header
 - 3 and 4 at the SSD Switch
 - 3 and 4 at the SSD header

The multimeter should show positive continuity in all cases.

- d. Verify the connections and rewire them if needed.

Section C - Wiring

Aux wiring: System Shutdown Switch

Wiring test for SSD Switch in the OFF position

- a. Ensure the SSD Switch is in the OFF position.



- b. Ensure the IQ System Controller is powered ON from any of the sources.

- c. Set the multimeter to measure DC voltage.

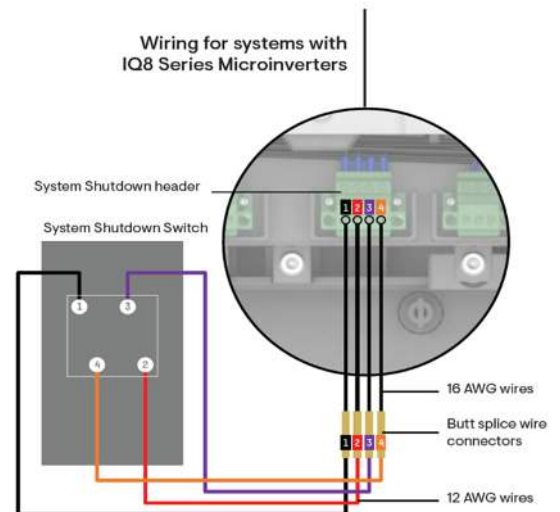

- d. Measure the terminal test points:
- 1 and 2 at the SSD Switch
 - 1 and 2 at the SSD header
 - 3 and 4 at the SSD Switch
 - 3 and 4 at the SSD header

The multimeter should show a value between 2.7 VDC and 3.3 VDC in all cases.

- e. Verify the connections and rewire them if needed.

Section C - Wiring

Aux wiring: IQ Load Controller

Up to two IQ Load Controllers, each enabling fine-grained, circuit-level control for 2×240 V or 4×120 V essential load circuits, can be integrated with the IQ System Controller. Each 240 V load can be controlled independently, but the 120 V loads can be controlled in groups of up to two loads. Sunlight Backup system needs at least one IQ Load Controller to be installed on the site.

For detailed wiring instructions, refer to the IQ Load Controller QIG.

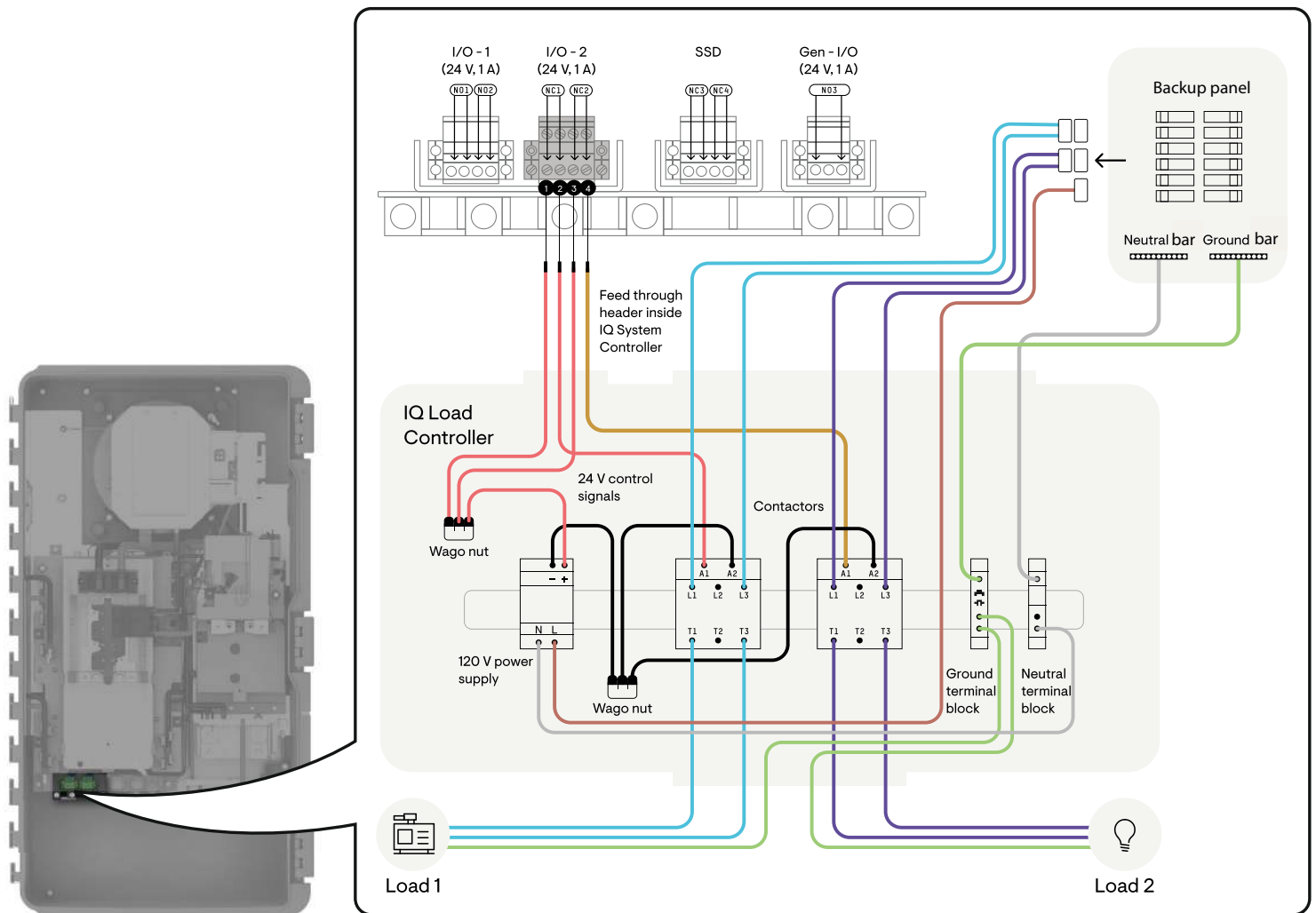

ⓘ **NOTE:** Control lines to headers support 28 AWG and 16 AWG wire gauges.

Section C - Wiring

IQ System Controller 3G - Aux wiring: Generator control

An auto-start generator can be integrated with the Enphase Energy System without the need for any external automatic transfer switch (ATS).

To view the full list of supported generators and more details, see [Generator Integration Tech Brief](#).

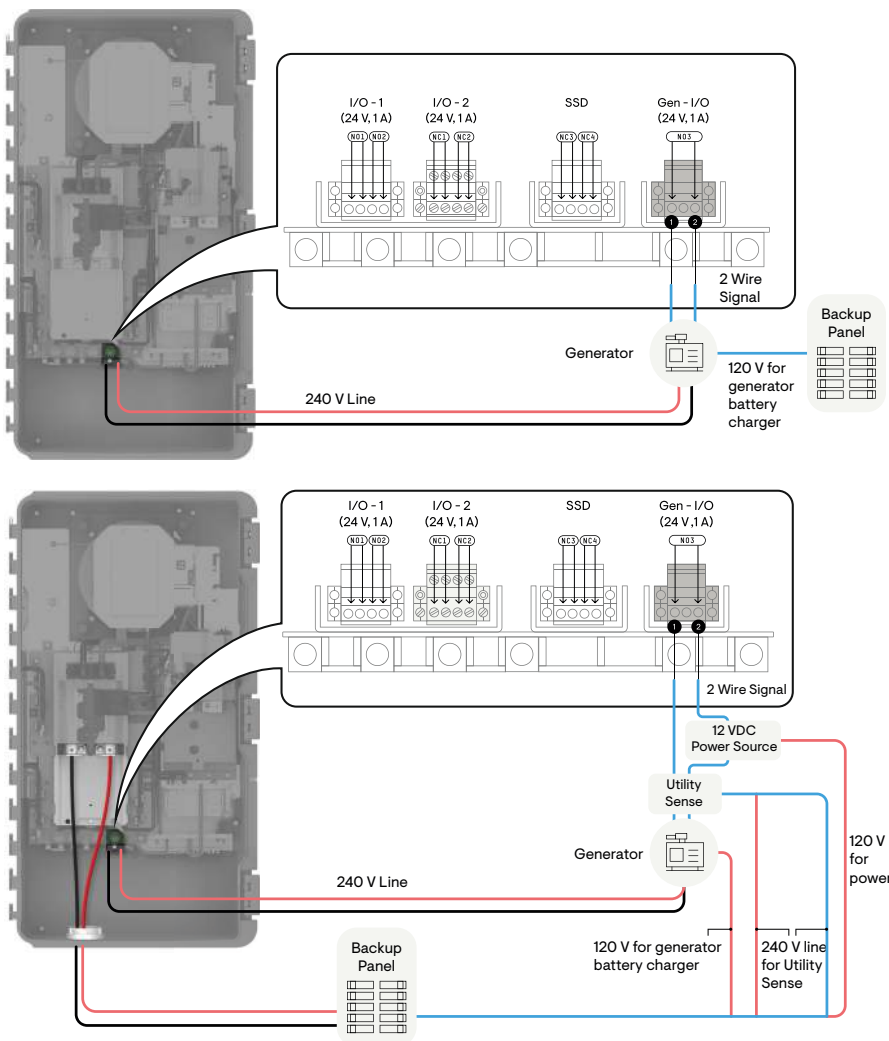

1. Install generator CTs (CT-200-CLAMP or CT-200-SPLIT) on the L1 and L2 wires from the generator and follow instructions in the CT wiring section to ensure power monitoring when the generator is running.
2. Use the Enphase Installer App to commission and program IQ System Controller 3G to control the generator.

- For 2-wire autostart generators, wire the generator I/O port in IQ System Controller 3G to the 2-wire remote start terminals of the generator.
- For utility sense generators, wire the input of a 12 V DC power supply to the backup loads panel.
- Wire one end of the DC power supply output to one of the terminals of the generator auxiliary contact (NO3) on the IQ System Controller 3G.
- Wire the other terminal of the generator auxiliary contact (NO3) to the coil of an external normally closed (NC) power relay.
- Wire the other end of the DC power supply output to the other end of the coil of the normally closed (NC) power relay.
- Wire one terminal of the external normally closed (NC) power relay to one of the poles of a double pole breaker on the backup loads panel.
- Wire the other terminal of the external normally closed (NC) power relay to one of the utility sense terminals on the generator through a fuse.
- Wire the 2nd pole of the double-pole breaker on the backup loads panel to the 2nd utility sense terminal on the generator via a fuse.

✓ **NOTE:** Control lines to headers support 28 AWG and 16 AWG wire gauges.

Refer to the technical brief and user guides for detailed instructions on generator integration. See the Generator Support page at <https://enphase.com/installers/storage/generator>. Always follow generator installation and operation instructions from the generator manufacturer.

Section C - Wiring

Mains/supply side wiring

The mains wiring is the final step in the installation process. The wiring is similar for both whole home and partial home backup.

When using Eaton CSR mains breaker

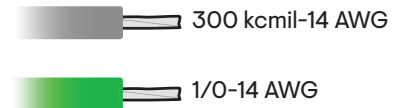
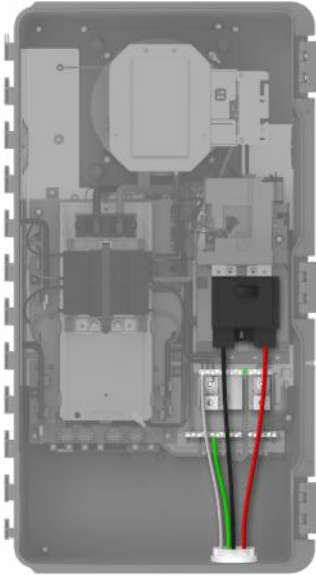

AWG	TORQUE (lb-in)
300 kcmil-2	250

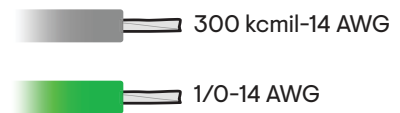
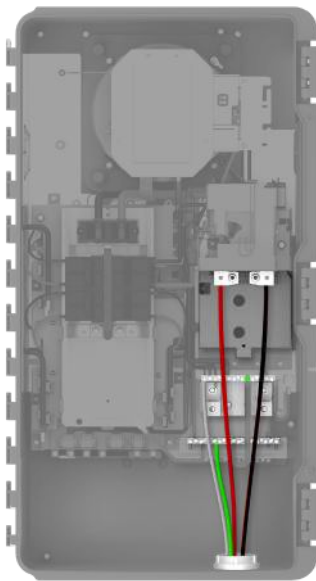

AWG	TORQUE (lb-in)
300 kcmil-6	275

NEUTRAL AND GROUND CONNECTIONS	AWG	TORQUE (lb-in)	
Neutral and ground bar – large holes	1/0-3	50	–
	4-6	45	⊘
	8	40	5/16"-24 UNF
Neutral and ground bar – small holes	10-14	35	–
	6-8	25	⊘
	10-14	15	#10-32 UNF
Neutral lugs	300 kcmil-6	275	⊘ 3/8"

⚠ WARNING: Tighten the Hex nut  and recheck the torque (48 lb-in) before every wire installation.

✔ NOTE: The ground bar doesn't support cables higher than 1/0 to be compliant with the bending radius as per the standards.

Section C - Wiring

Backup loads wiring

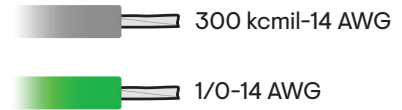
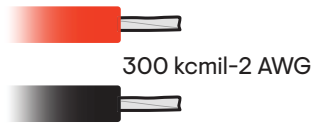
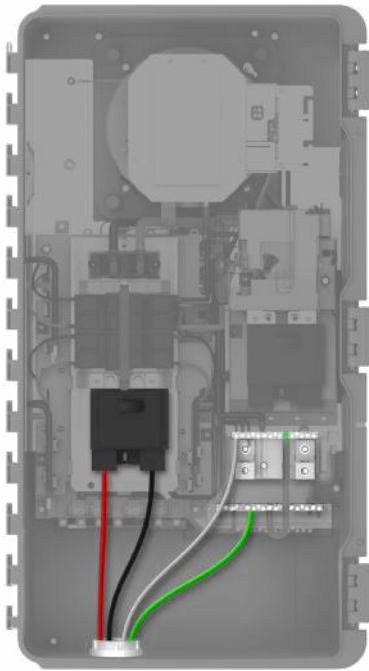

AWG	TORQUE (LB.IN)
300 kcmil-2	250

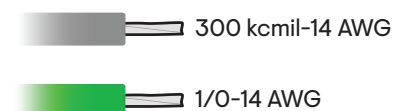
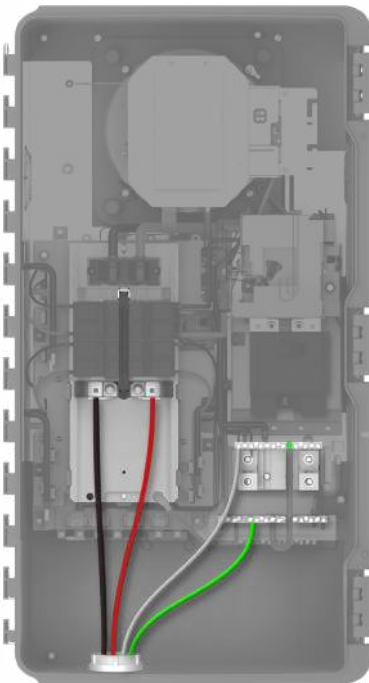

AWG	TORQUE (LB.IN)
300 kcmil-6	275

NEUTRAL AND GROUND CONNECTIONS	AWG	TORQUE (LB.IN)	
Neutral and ground bar – large holes	1/0–3	50	–
	4–6	45	⊘
	8	40	5/16"–24 UNF
	10–14	35	–
Neutral and ground bar – small holes	6–8	25	⊘
	10–14	15	#10–32 UNF
	300 kcmil-6	275	⊕ 3/8"

⚠ WARNING: Tighten the Hex nut  and recheck the torque (48 lb-in) before every wire installation.

Section C- Wiring

IQ System Controller 3- Backup loads wiring (using a storage breaker position not connected to an IQ Battery)

The configuration is applicable for a storage breaker position not connected to an IQ Battery on the IQ System Controller 3. The IQ System Controller 3 is capable of supporting total backup loads below 64 A by utilizing the empty storage breaker slots on the load center.

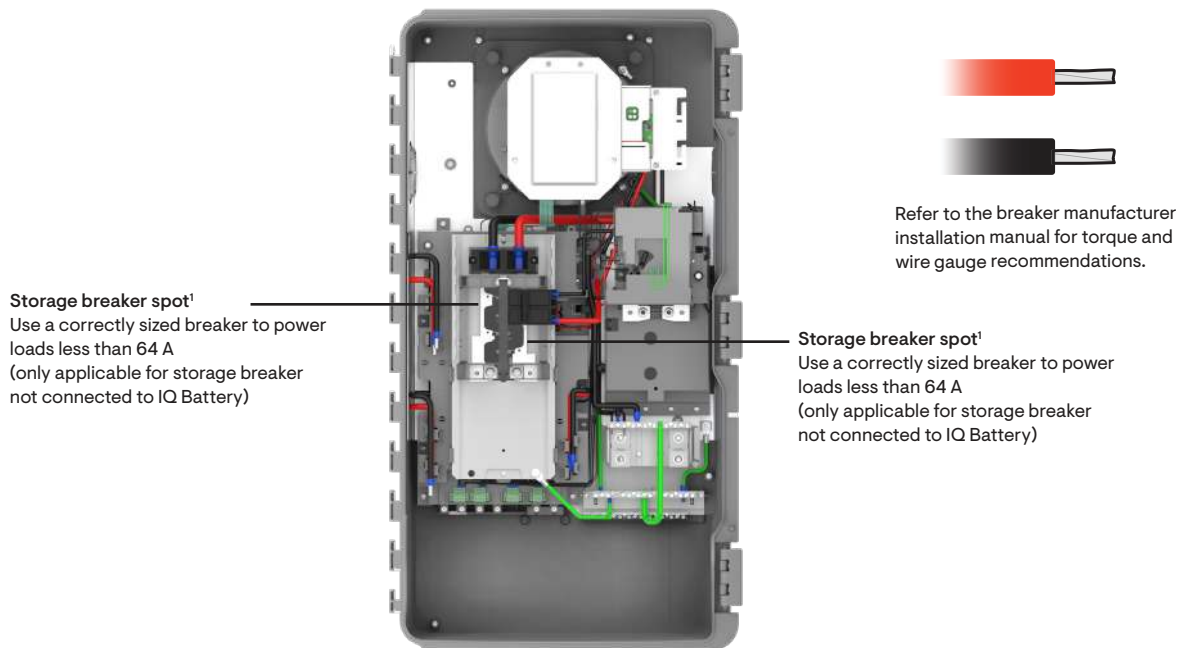
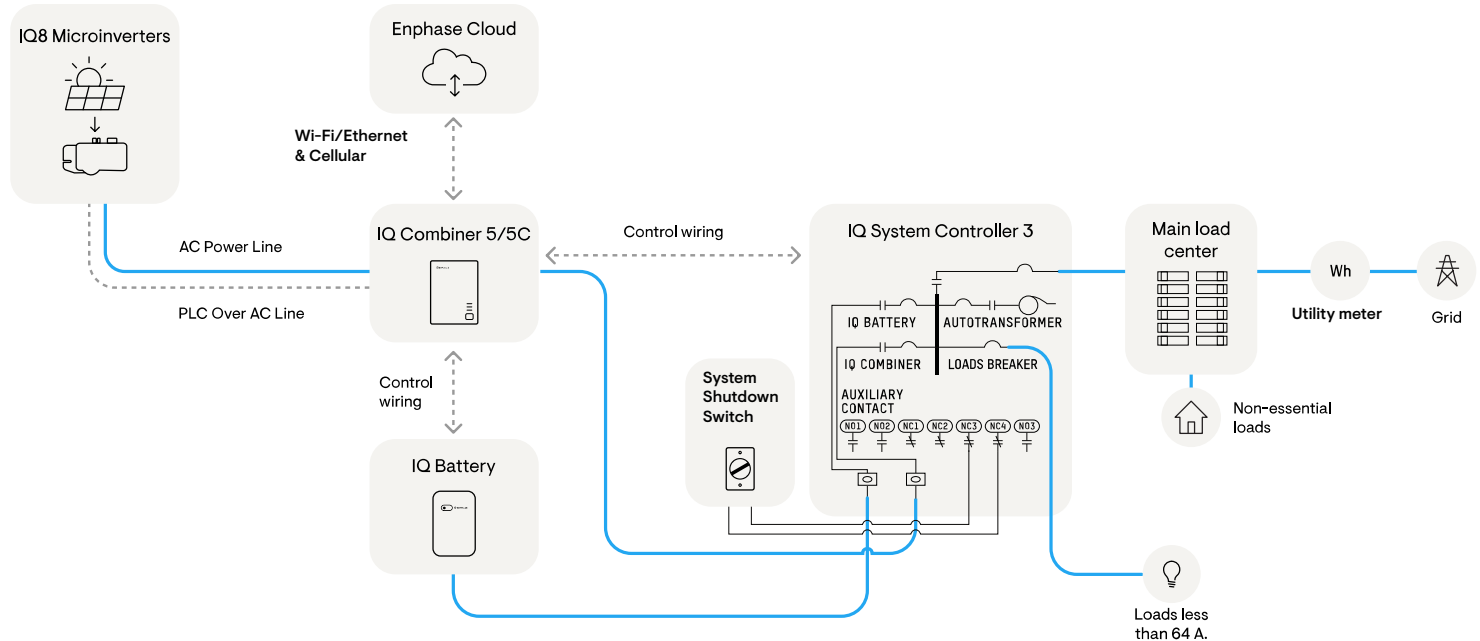

¹ Either one of the storage breaker spots must be used for connection to loads.

⊙ **NOTE:** Refer to [Section B- Mounting the Breakers](#) for a list of approved breakers that can be used at the load center.

⚠ **WARNING:** Do not connect loads on backup lugs with this configuration.

Section C- Wiring

IQ System Controller 3G- Backup loads wiring (using a storage or generator breaker position not connected to an IQ Battery or a generator)

The configuration is applicable for a storage or generator breaker position not connected to an IQ Battery or a generator on the IQ System Controller 3G. The IQ System Controller 3G is capable of supporting total backup loads below 64 A by utilizing the empty storage/generator breaker slots on the load center.

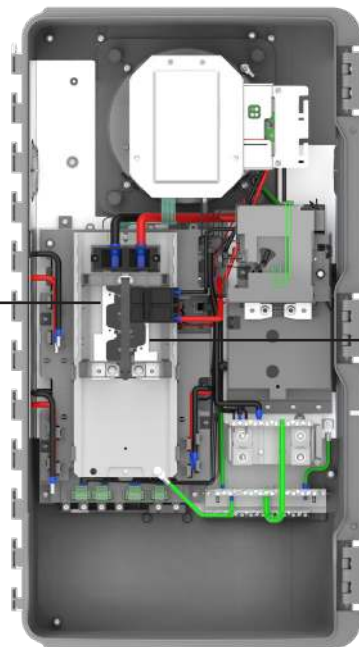
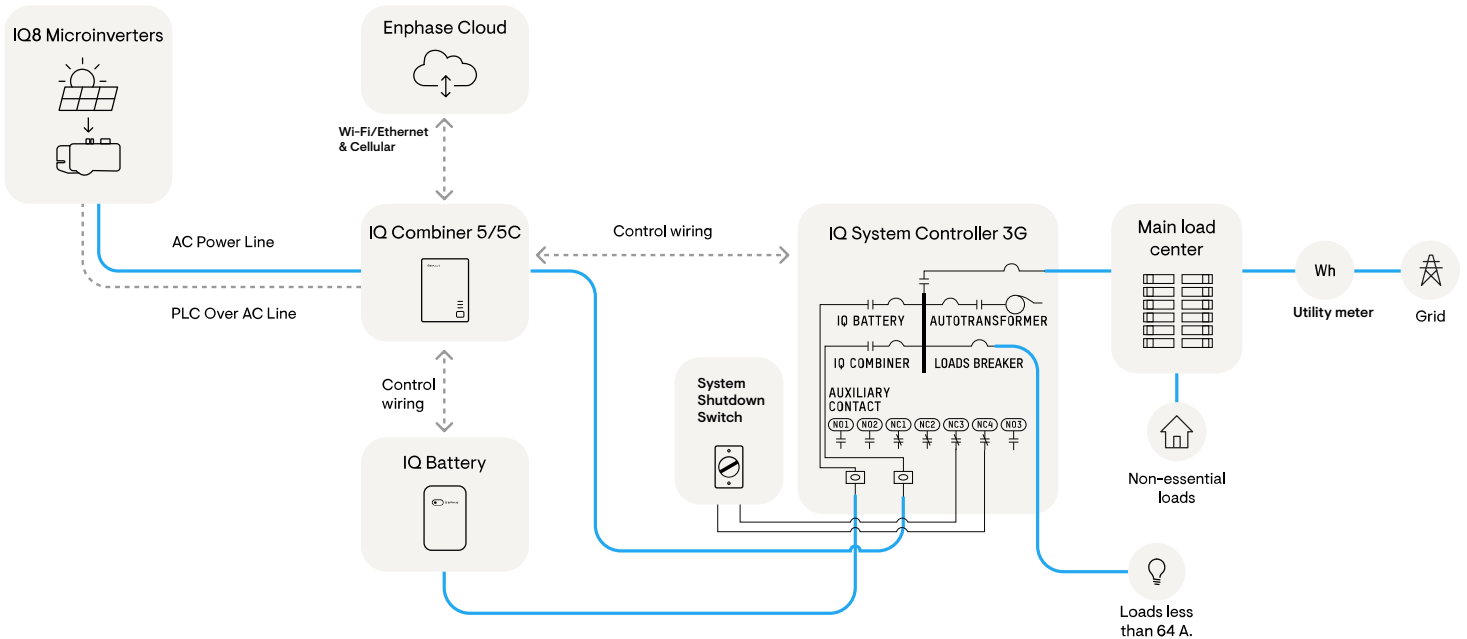

Storage breaker spot¹
Use a correctly sized breaker to power loads less than 64 A (only applicable for storage breaker not connected to IQ Battery)

Generator breaker spot¹
Use a correctly sized breaker to power loads less than 64 A (only applicable for generator breaker not connected to a generator)



Refer to the breaker manufacturer installation manual for torque and wire gauge recommendations.

¹ Either the storage or the generator spot must be used for connection to loads.

☑ **NOTE:** Refer to [Section B- Mounting the Breakers](#) for a list of approved breakers that can be used at the load center.

⚠ **WARNING:** Do not connect loads on backup lugs with this configuration.

Section C - Wiring

CT wiring

There are multiple scenarios for CT wiring. Refer to CT wiring scenarios. For more description, refer to the IQ Gateway quick install guide. For PCS setup, refer to the PCS section.

Place the Consumption CTs as shown for:

- Whole home backup
- Partial home backup with power control systems (PCS) for main panel upgrade (MPU) avoidance
- Any system with generator integration

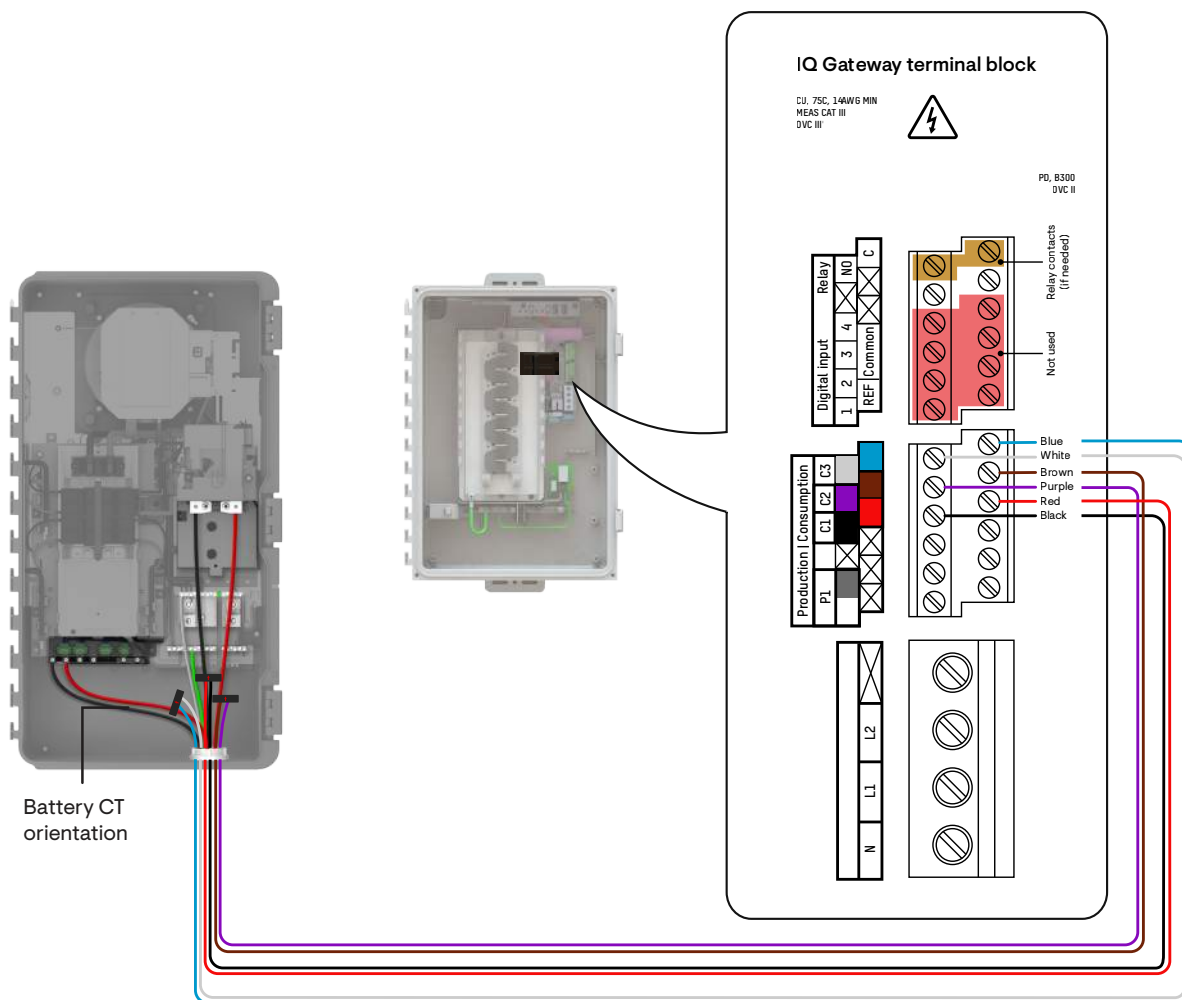

- Battery CT shall be placed on L2 of all IQ Battery circuits.
- Consumption CTs shall be placed on the L1 and L2 mains wiring to the IQ System Controller.
- For partial home backup systems (without generator integration and PCS), for MPU avoidance, place the CTs on L1 and L2 between the meter and the main panel.
- If using CT-200-SPLIT, ensure the CT has a "Service Entrance Rated" label on it.
- When installing a generator, the generator CTs should be paralleled to the Consumption CTs wiring using a Wago nut.

Section C - Wiring

CT wiring scenarios

Scenario 1: CT wiring for IQ Battery on both IQ Battery and DER ports (IQ System Controller 3 only)

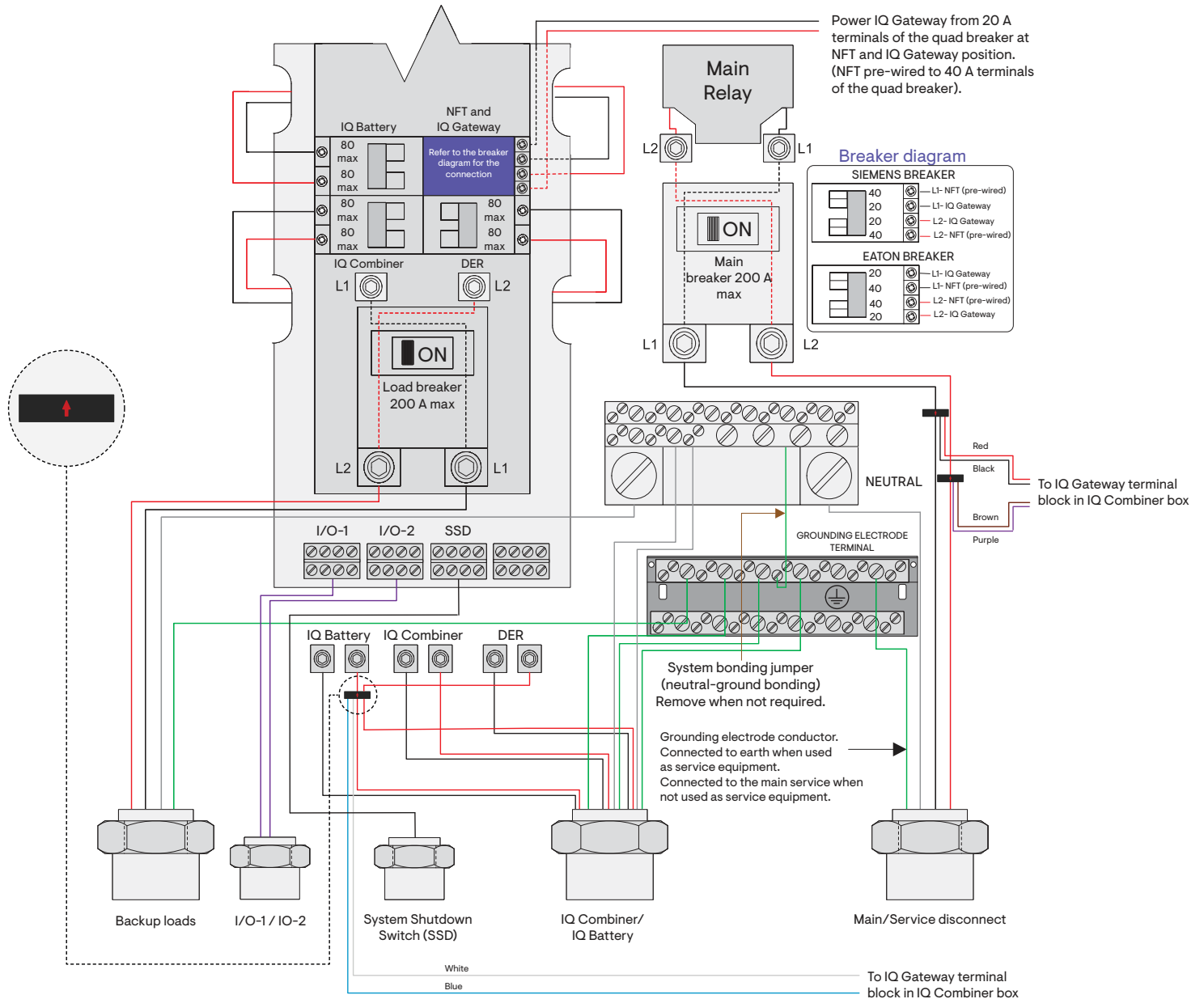

Section C - Wiring

Scenario 1: CT wiring for IQ Battery on both IQ Battery and DER ports (IQ System Controller 3 only)

Battery CT will be placed on the L2 wire from the IQ Battery port and the DER port. L2 of IQ Battery and DER port shall be paralleled using one Battery CT.

Consumption CTs must be placed on the L1 and L2 mains wiring to the IQ System Controller 3.

Consumption CT placement configurations

- Consumption CT is placed between IQ System Controller 3 and the main panel.
- Consumption CT is placed between the main panel and the utility meter.

☑ **NOTE:** For more details, refer to the PCS section.

Section C - Wiring

Scenario 2: CT wiring for IQ Battery on IQ Battery port and Generator on DER port (IQ System Controller 3G only)

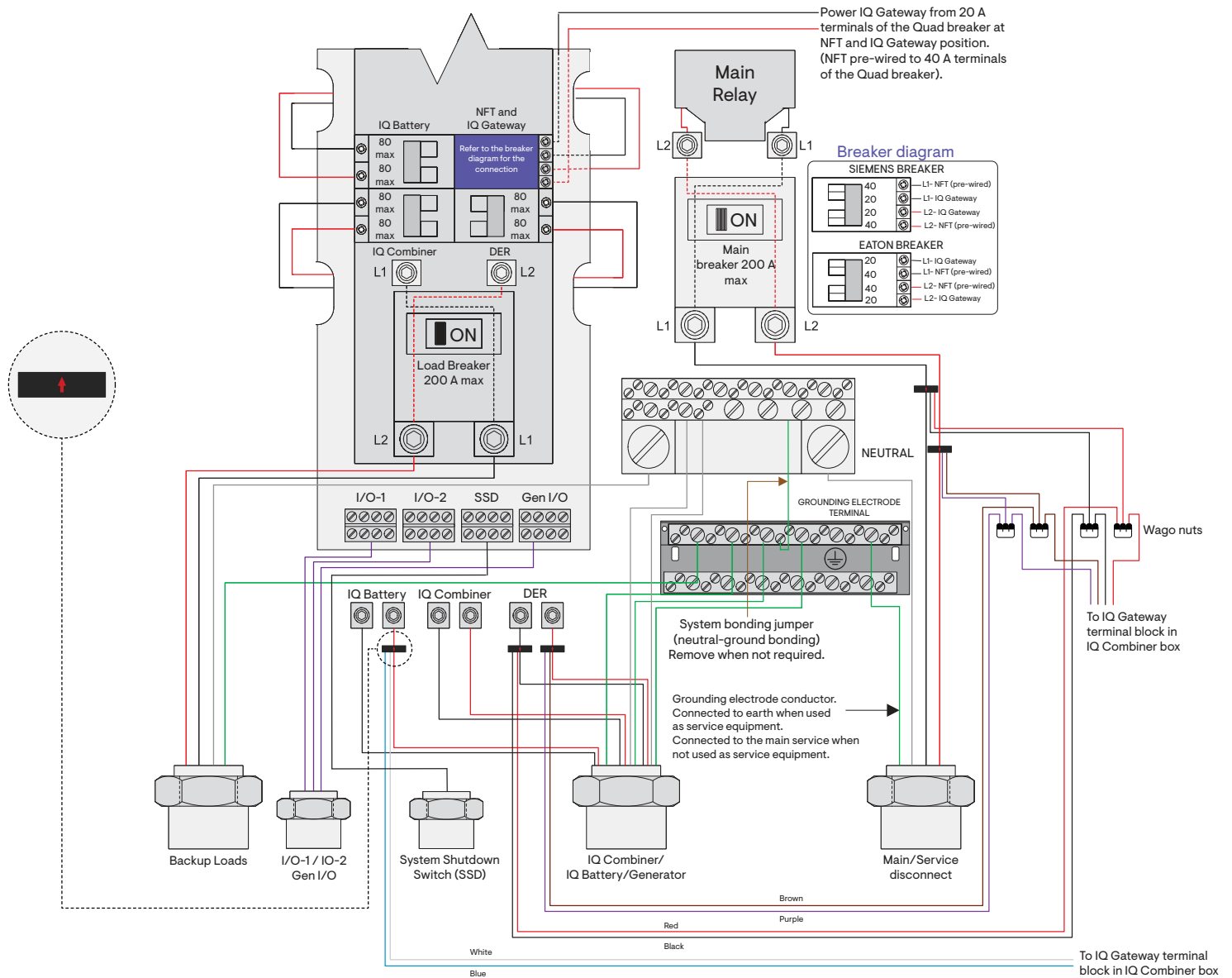

Battery CT shall be placed on the L2 wire from the IQ Battery port.

Consumption CTs are placed on the L1 and L2 mains wiring to the IQ System Controller 3G.

When installing a generator, the generator CTs shall be paralleled to the Consumption CT wiring using a Wago nut.

Consumption CT must be placed between the IQ System Controller and the main panel for the IQ System Controller 3G.

Section C - Wiring

Wiring control (CTRL) cable to headers

✓ **NOTE:** The control cable required for IQ Battery 5P, IQ Combiner 5/5C, and IQ System Controller 3/3G must be compliant with UL 3003, UL 1277, and UL 83 standards. The Enphase control cable (SKU: CTRL-SC3-NA-01) with optimal impedance to ensure control communication has been validated for optimal system performance. Third-party cables may not have the correct characteristic impedance and consequently may not work for reliable control communication.

✓ **NOTE:** The IQ System Controller supports control wiring but will not support Zigbee communication.
Enphase SKU for control cable: CTRL-SC3-NA-01

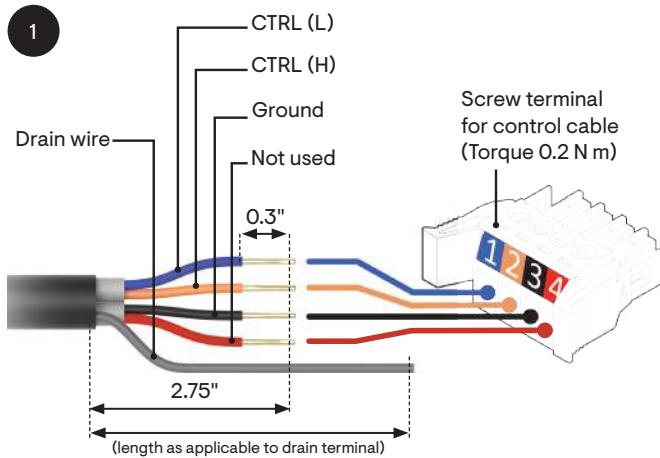

Control cable to be stripped to recommended dimensions and connected to the header. Also, may leave the 4th CTRL cable (red cable) unconnected.

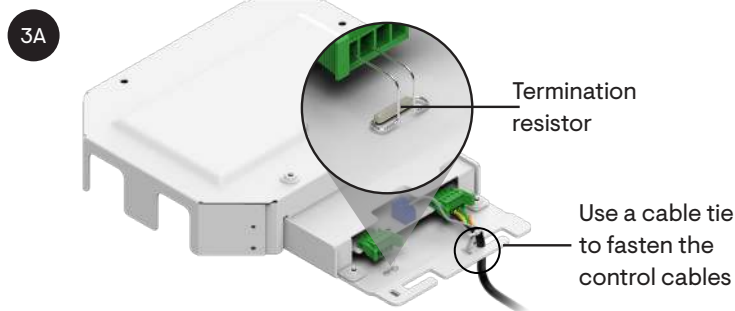

Scenario A: The IQ System Controller is the terminal node for the wired control network. Use control cable of length 40 in + conduit length and use termination resistor provided with Lit Kit. CTRL header positions can be interchanged based on the system setup.

2

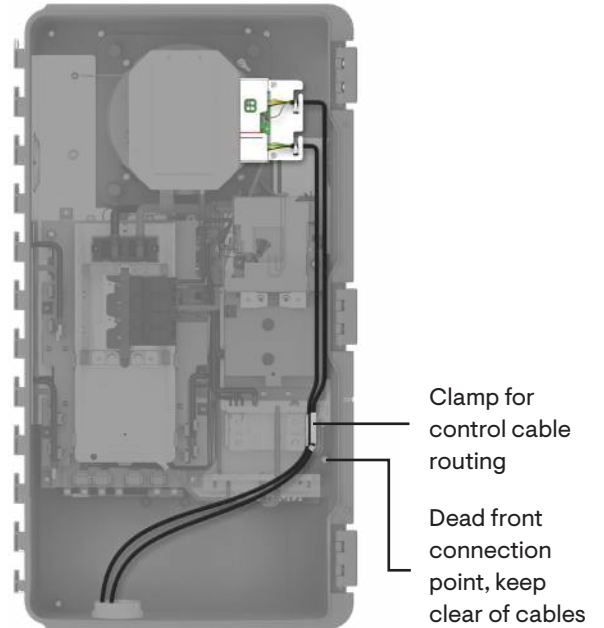

Control cable routing inside IQ System Controller. Do not use side conduits for control cable routing.

3B

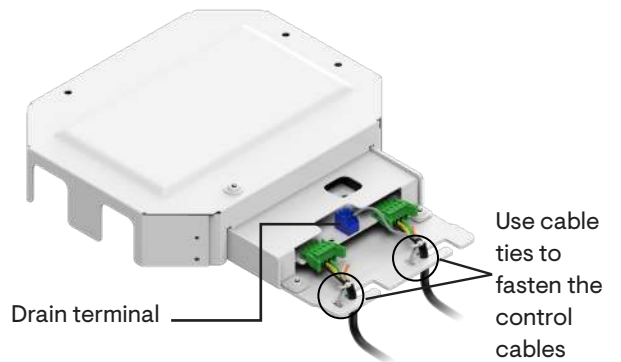

Scenario B: The IQ System Controller is not the terminal node for the wired control network. Use a control cable of length 40 in + conduit length on each side.

Connect the drain wire to the drain terminal only at one end of a CTRL cable. Do not connect drain wires at both ends of a CTRL cable.

Section C - Wiring

Control (CTRL) wiring between system components

Control wiring guidance for the Enphase Energy System:

Refer to the following wiring sequences to understand the position of the header with termination resistor, wiring order, and drain wire termination location.

☑ **NOTE:** Ensure the following guidelines are followed to avoid failures during system commissioning:

- One header with a termination resistor should be installed on each component that is at the end of the control network.
- The drain wire should only be terminated on one end of the control wiring between system components.
- It is recommended that the drain wire be terminated at the component from which the control wiring for the section is initiated.

- Ensure that the conductor is stripped for control cable length to allow the drain wire to adequately reach the drain port on one side of the cable (only).
- The same conduits can be used for power and control wire routing only when using an Enphase CTRL cable, i.e., CTRL-SC3-NA-01.

The following are four common wiring sequences:

Sequence 1a: IQ Combiner 5/5C → IQ System Controller 3G → IQ Battery(s) 5P

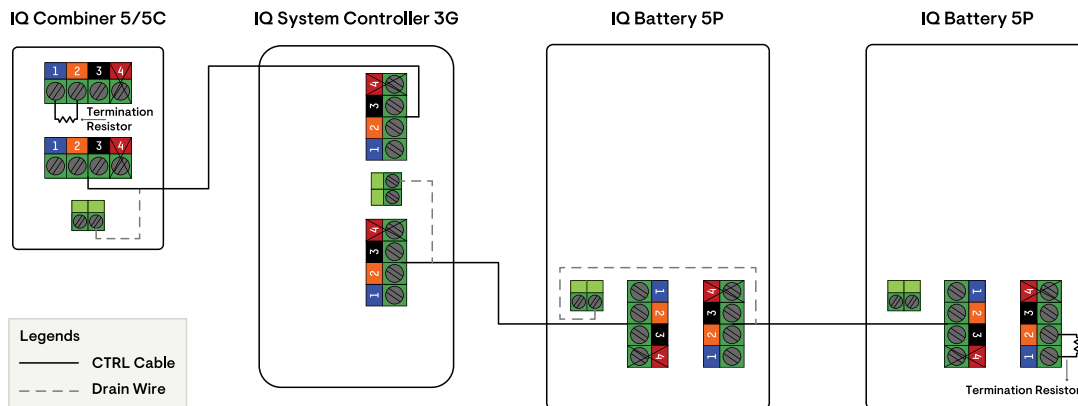

☑ **NOTE:** The total length of CTRL wiring across the system cannot exceed 250 ft to ensure the system operates as per specifications.

⚠ **WARNING:** The drain wire should only be terminated on one end of the control wiring between the system components to prevent ground loops.

⚠ **WARNING:** Do not wire the System Shutdown (SSD) Switch 4 wire cables to the control cable header. Doing so will result in a communication breakdown of the Enphase Energy System.

Section C - Wiring

Sequence 1b: IQ Combiner 5/5C → IQ System Controller 3 → IQ Battery(s) 5P

(This is only applicable to IQ System Controller 3, where the third DER port can be used for additional batteries)

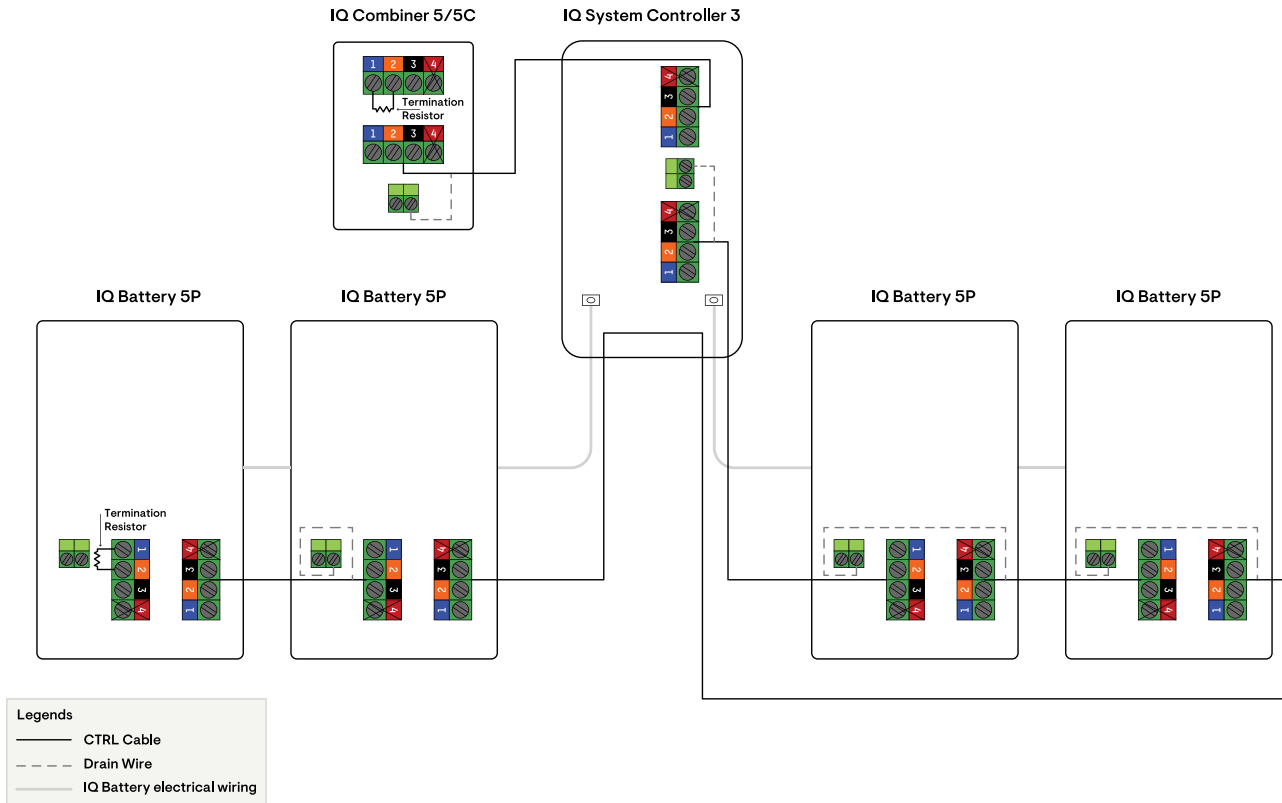

✔ **NOTE:** The total length of CTRL wiring across the system cannot exceed 250 ft to ensure the system operates as per specifications.

⚠ **WARNING:** The drain wire should only be terminated on one end of the control wiring between the system components.

Sequence 2: IQ Combiner 5/5C → IQ Battery(s) 5P → IQ System Controller 3/3G

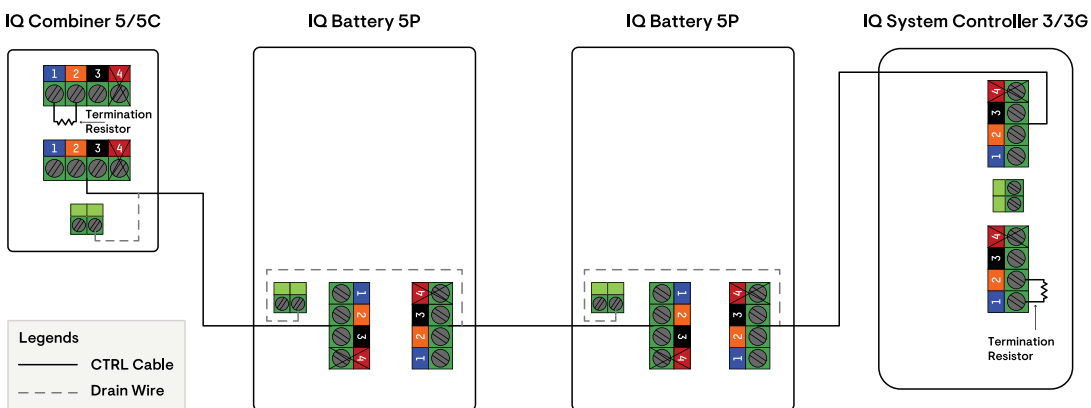

✔ **NOTE:** The total length of CTRL wiring across the system cannot exceed 250 ft to ensure the system operates as per specifications.

⚠ **WARNING:** The drain wire should only be terminated on one end of the control wiring between the system components to prevent ground loops.

Section C - Wiring

Sequence 3: IQ System Controller 3/3G → IQ Combiner 5/5C → IQ Battery(s) 5P

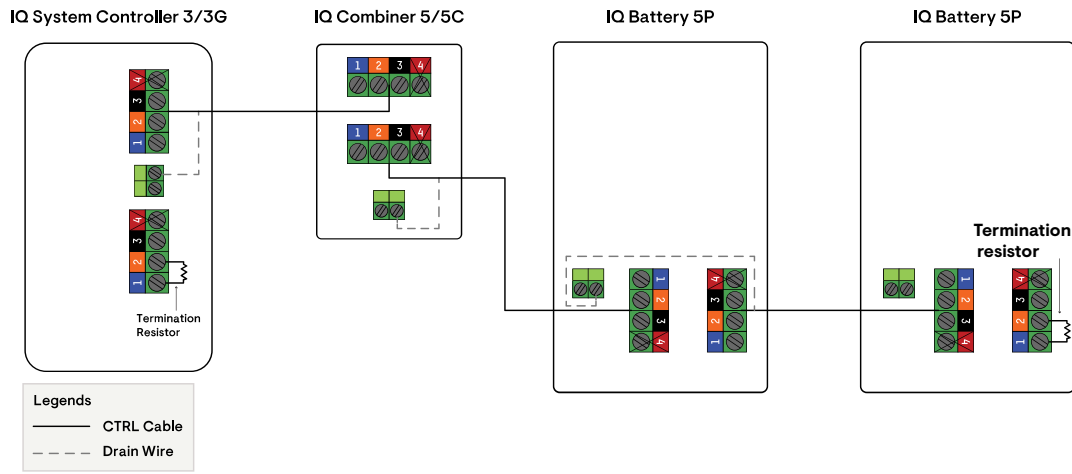

NOTE: The total length of CTRL wiring across the system cannot exceed 250 ft to ensure the system operates as per specifications.

WARNING: The drain wire should only be terminated on one end of the control wiring between the system components to prevent ground loops.

Here is a table providing termination resistor locations for the above sequences:

CONTROL WIRING SEQUENCE	TERMINATION RESISTOR LOCATION
IQ Combiner 5/5C → IQ System Controller 3G → IQ Battery(s) 5P	<ul style="list-style-type: none"> IQ Combiner 5/5C Last IQ Battery 5P in the daisy chain
IQ Combiner 5/5C → IQ System Controller 3 → IQ Battery(s) 5P	<ul style="list-style-type: none"> IQ Combiner 5/5C Last IQ Battery 5P in the daisy chain
IQ Combiner 5/5C → IQ Battery(s) 5P → IQ System Controller 3/3G	<ul style="list-style-type: none"> IQ Combiner 5/5C IQ System Controller 3/3G
IQ System Controller 3/3G → IQ Combiner 5/5C → IQ Battery(s) 5P	<ul style="list-style-type: none"> IQ System Controller 3/3G Last IQ Battery 5P in the daisy chain

Section D

Power Control System (PCS)

Introduction

The Enphase Energy System supports four Power Control System (PCS) use cases:

1. Main panel upgrade (MPU) avoidance mode: This feature, applicable in a partial home backup scenario, limits the back feed to the grid to avoid upsizing the main panel.

The National Electric Code (NEC) 2020 705.12 allows the back feed of current from solar or storage into the main panel subject to the following limits:

Backfeed allowed = ((120% of busbar rating) - Ampacity of the overcurrent protection device protecting the busbar)/125%.

2. Battery import-only mode for Enphase Energy System: This feature ensures the IQ Battery 5P never exports any power to the grid. This applies regardless of the configured battery smart profile, i.e., self-consumption, full backup, or savings (time of use) with optimization.
3. Aggregate power export limit mode: This feature ensures that the aggregate power exported to the grid is limited to the aggregate power export limit (PEL) defined by the installer.
4. IQ Battery oversubscription mode: This feature allows for more IQ Batteries to be installed against a given IQ Battery breaker in the IQ System Controller by ensuring that the total continuous output current from the IQ Batteries on the battery port does not exceed 80% of the battery breaker rating.

IQ SYSTEM CONTROLLER SKU	MAX NO. OF IQ BATTERY 5P	PORTS SUPPORTED	MAXIMUM ENERGY (KWH)	MAXIMUM POWER (KW)
SC200D111C240US01	16*	IQ Battery and DER	80 kWh	30.72 kW
SC200G111C240US01	8	IQ Battery	40 kWh	15.36 kW

*Maximum of eight each on IQ Battery port and additional IQ Battery port.

Section D - PCS

Setting up PCS on-site during commissioning

1. Ensure the availability of the following Enphase products as required on-site to implement PCS.

PRODUCT	SKU
IQ System Controller 3/3G	SC200D11C240US01, SC200G11C240US01
IQ Combiner 5/5C	X-IQ-AM1-240-5, X-IQ-AM1-240-5C
IQ Battery 5P	IQBATTERY-5P-1P-NA
Microinverters	IQ8 Series

2. Installation of the CTs

Based on the type of configuration and the PCS feature being enabled, the CTs may have to be installed in different locations on a site.

CT TYPE	QUANTITY	LOCATION	PLACEMENT	DIRECTION OF ARROW
Consumption CT	2	IQ System Controller	Conductor from the mains breaker to the main panel or the utility meter	Towards the mains breaker inside the IQ System Controller 3/3G
Battery CT	1	IQ System Controller	L2 of all IQ Battery circuits	Away from the IQ Battery (towards the battery lugs on the IQ System Controller)

- ⊙ **NOTE:** For partial home backup systems with the main panel upgrade avoidance feature enabled, the Consumption CTs must be installed between the IQ System Controller 3/3G and the main panel to monitor and control the current back-fed from the IQ System Controller to the main panel. Installing the CTs at this location would impact the aggregate power export limiting (PEL) feature if another DER source is installed on the main panel.
 - ⊙ **NOTE:** Refer to the CT Wiring section for details.
3. Ensure all PCS-controlled busbars and/or conductors are protected with suitably rated overcurrent devices that are appropriately sized for the busbar rating or conductor ampacity.
 4. For sites with main panel upgrade (MPU) avoidance mode enabled, indicate this with the label.

Record the maximum operating current value on the label.

The label is provided as part of the IQ System Controller Literature kit.

MPU avoidance label

THE MAXIMUM CURRENT BACKFED BY THIS SYSTEM TO THE MAIN PANEL MAY BE CONTROLLED ELECTRONICALLY. REFER TO THE MANUFACTURER'S INSTRUCTIONS FOR MORE INFORMATION.

PCS CONTROLLED CURRENT SETTINGS: AMPS

Recommended area to affix - On the dead front below the transparent breaker, position the cover for the mains breaker.

Section D – PCS

- 5. For sites with aggregate export power limit (PEL) enabled, indicate this with the label. Record the maximum operating kW value on the label.

The label is provided as part of the IQ System Controller Literature kit.

AGGREGATE POWER EXPORT LIMIT LABEL:



Recommended area to affix: On the dead front, below the transparent breaker, position the cover for the main breaker.

- 6. For sites with IQ Battery Oversubscription enabled, indicate this with the label.

Record the maximum operating current value on the label.

The label is provided as part of the IQ System Controller Literature kit.

IQ BATTERY OVERSUBSCRIPTION LABEL

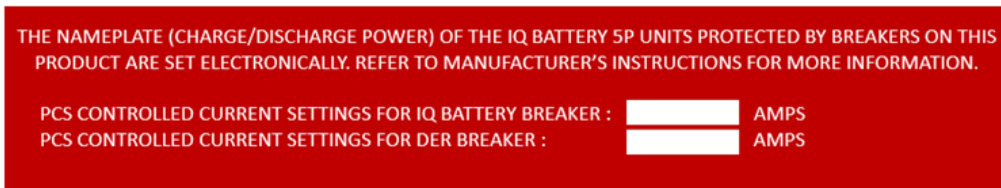

Recommended area to affix: On the dead front, below the transparent breaker, position the cover for the main breaker.

- 7. For sites with PCS enabled, indicate this with the label.

The label is provided as part of the IQ System Controller Literature kit.

CT LABEL



Recommended area to affix: On the CTs

- 8. Use the site configurations section in the Enphase Installer App to define the PCS settings for the site.

Close and energize IQ System Controller

 **WARNING:** Connect the AC wires of the IQ Combiner, IQ Batteries, and the generator into the terminal lugs at the bottom of the IQ System Controller load center on the left. Do not connect the AC wires directly to the breakers. The AC wires go into the terminal lugs, as shown on the label.

- A. Before energizing, make sure that all IQ System Controller wiring is complete.

 **WARNING:** If not commissioning the system, you must ensure that the DC switches on all IQ Batteries are turned off to avoid the depletion of charge on the IQ Batteries.

- B. Reconnect the dead front ground cable to the grounding bar. Place the dead front using the five reserved screws. Tighten the cover screws using a Phillips screwdriver.

 **WARNING:** Risk of equipment damage. Ensure that no conductors are pinched before placing the dead front.

 **WARNING:** If either solar, storage, or generator circuits are not used in an installation, their respective red and black colored conductors should remain stowed in the clips on the plastic frame supporting the panel board interior, and their end caps should not be removed.

 **DANGER:** Risk of electric shock. There are many potential sources of voltage. Check any IQ Battery, PV, or other generation sources for voltage.

 **WARNING:** Risk of equipment damage. Do not wire the IQ System Controller when it is energized.

- C. If you work on an IQ6, IQ7, or M Series retrofit system, and you plan to energize the IQ System Controller and connect the PV without commissioning the system on the same day, follow the sequence below:

- a. Leave the IQ Combiner breaker in the load panel where it was originally placed instead of connecting the IQ Combiner L1 and L2 circuits to the terminal lugs in the IQ System Controller. This way, your PV systems can still be functional before commissioning.
- b. TURN OFF the DC switches on all batteries.

- c. OPEN the IQ Battery breaker in the IQ System Controller.

- d. CLOSE breakers in the following order:

1. Mains breaker
2. Load breaker

 **WARNING:** At commissioning, you must reconnect the IQ Combiner L1 and L2 circuits back to the terminal lugs in the IQ System Controller.

- D. If you plan to commission the system, follow the instructions in the Enphase Installer App to provision and energize the Enphase Energy System.

- E. Once connected to the IQ Gateway, refer to the Enphase Installer App help topics for more information.

- F. If you do not see the IQ System Controller information in the Enphase Installer App, check if the IQ Gateway AP mode light is green. If not, press the AP mode button and follow the instructions in the Enphase Installer App to connect the phone to the IQ Gateway's Wi-Fi network.

- G. Remember to close and secure the door of the IQ System Controller before leaving the site.

Safety

IMPORTANT SAFETY INSTRUCTIONS. SAVE THESE INSTRUCTIONS. This guide contains important instructions that you must follow during the installation and maintenance of the IQ System Controller 3/3G. Failing to follow any of these instructions may void the warranty (<https://enphase.com/warranty>).

In case of fire or other emergency

In all cases:

- If safe to do so, turn off all DC switches on each IQ Battery.
- Turn off the PV breaker and battery breakers inside the IQ System Controller.
- Turn off the AC breaker for the IQ System Controller circuit.
- If an isolator switch is present, switch off the AC isolator for the IQ System Controller circuit.
- Contact the fire department or other required emergency response team.
- Evacuate the area.

In case of fire:

- When safe, use a fire extinguisher. Suitable types are A, B, and C dry chemical fire extinguishers. Additional extinguishing media include carbon dioxide or alcohol-resistant foams.



In case of flooding:

- Stay out of the water if any part of the IQ System Controller or wiring is submerged.
- If possible, protect the system by finding and stopping the source of the water and pumping it away.
- If water has contacted the unit, call your installer to arrange an inspection. If you are sure that water has never contacted the battery, let the area dry completely before use.







In case of unusual noise, smell, or smoke:

















- Ensure nothing is in contact with the IQ System Controller or the venting area on top of the IQ System Controller.
- Ventilate the room.
- Contact Enphase Support at <https://enphase.com/support>.

Safety and advisory symbols

-  **DANGER:** This indicates a hazardous situation, which, if not avoided, will result in death or serious injury.
-  **WARNING:** This indicates a situation where failure to follow instructions may be a safety hazard or cause equipment malfunction. Use extreme caution and follow instructions carefully.
-  **NOTE:** This indicates information particularly important for optimal system operation. Follow instructions carefully.

Safety instructions

-  **DANGER:** Risk of electric shock. Risk of fire. Only qualified electricians should install, troubleshoot, or replace the IQ System Controller.
-  **DANGER:** Risk of electric shock. Risk of fire. Do not attempt to repair the IQ System Controller. Tampering with or opening the IQ System Controller will void the warranty. If the IQ System Controller fails, contact Enphase Support for assistance at <https://enphase.com/support>.
-  **DANGER:** Risk of electric shock. Do not use Enphase equipment in a manner not specified by the manufacturer. Doing so may cause death or injury to persons or damage to equipment.
-  **DANGER:** Risk of electric shock. Do not install the IQ System Controller without first removing AC power from the photovoltaic system and ensuring that the DC switch on the IQ Batteries is off. Disconnect the power coming from the photovoltaics and ensure that the DC switch on the IQ Batteries is off before servicing or installing.
-  **DANGER:** Risk of electric shock. Risk of fire. Do not work alone. Someone should be in the range of your voice or close enough to come to your aid when you work with or near electrical equipment.
-  **DANGER:** Risk of fire. Do not allow or place flammable, sparking, or explosive items near the IQ System Controller.
-  **DANGER:** Risk of electric shock. In areas where flooding is possible, install the IQ System Controller at a height that prevents water ingress.

-  **WARNING:** Risk of equipment damage. IQ System Controller is shipped and stored on its back. The upright position is only needed when installed.
-  **WARNING:** You must install the IQ System Controller only on a suitable wall using an Enphase wall-mount bracket.
-  **WARNING:** Before installing or using the IQ System Controller, read all instructions and cautionary markings in this guide and on the equipment.
-  **WARNING:** Do not install or use the IQ System Controller if it has been damaged in any way.
-  **WARNING:** Do not sit on, step on, place objects on, or insert objects into the IQ System Controller.
-  **WARNING:** Do not place beverages or liquid containers on top of the IQ System Controller. Do not expose the IQ System Controller to flooding.
-  **NOTE:** Perform installation and wiring, including protection against lightning and resulting voltage surges, in accordance with all applicable local electrical codes and standards.
-  **NOTE:** Because IQ Battery is grid forming, you must install signage in accordance with NEC articles 705, 706, and 710.
-  **NOTE:** Using unapproved attachments or accessories could result in damage or injury.
-  **NOTE:** Install properly rated over current protection as part of the system installation.
-  **NOTE:** To ensure optimal reliability and to meet warranty requirements, the IQ System Controller must be installed and/or stored according to the instructions in this guide.
-  **NOTE:** The IQ System Controller is compatible only with the IQ Combiner 5/5C with CTRL cable wiring terminals, Production CT, and Consumption/PCS CTs. The IQ Combiner with the IQ Gateway inside is required for the operation of the IQ System Controller. Earlier versions of the IQ Gateway communications gateway are incompatible.
-  **NOTE:** The Enphase IQ System Controller is intended to operate with an internet connection through the IQ Gateway. Failure to maintain an internet connection may have an impact on the warranty. See limited warranty for full terms and services (<https://enphase.com/warranty>).
-  **NOTE:** When replacing an IQ System Controller, you must replace it with an IQ System Controller of the same type with the same AC current rating.
-  **NOTE:** Properly mount the IQ System Controller. Ensure that the mounting location is structurally suited to bearing the weight of the IQ System Controller.
-  **NOTE:** During use, storage, and transport, keep the IQ System Controller:
 - Properly ventilated
 - Away from the water, other liquids, heat, sparks, and extended exposure to direct sunlight
 - Away from excessive dust, corrosive and explosive gases, and oil smoke
 - Away from direct exposure to gas exhaust, such as from motor vehicles
 - Away from falling or moving objects, including motor vehicles. If mounted in the path of a motor vehicle, we recommend a 91 cm (36 in) minimum mounting height
 - In a location compliant with fire safety regulations
 - In a location compliant with local building codes and standards
-  **NOTE:** IQ System Controller is not suitable for use as service equipment in Canada.



Environmental protection

ELECTRONIC DEVICE: DO NOT THROW AWAY. Waste electrical products should not be disposed of with household waste. Refer to your local codes for disposal requirements.

Addendum A: Wire sizes and tightening torque

CIRCUIT	TIGHTENING TORQUE (N*M/IN*LBS)	WIRE SIZE (AWG/KCMIL/MCM)	WIRE TYPE	WIRE MINIMUM TEMP RATING
Main lugs	31.1/275	300 kcmil-6	Cu/Al	75°C
Backup load lugs	31.1/275	300 kcmil-6	Cu/Al	75°C
Main/backup lugs hex nut	5.4/48	—	—	75°C
CSR breaker bottom wiring lugs	28.2/250	300 kcmil-2	Cu/Al	75°C
BR breakers (pre-installed wires)	3.1/27	6 AWG	Cu	75°C
IQ Combiner lugs	2.8/25 3.4/30 3.9/35 4.5/40	10-14 AWG 8 AWG 4-6 AWG 2-3 AWG	—	75°C
IQ Battery lugs	2.8/25 3.4/30 3.9/35 4.5/40	10-14 AWG 8 AWG 4-6 AWG 2-3 AWG	—	75°C
DER lugs	2.8/25 3.4/30 3.9/35 4.5/40	10-14 AWG 8 AWG 4-6 AWG 2-3 AWG	—	75°C
Neutral (large lugs)	31.1/275	300 kcmil-6	Cu/Al	75°C
Neutral and ground bars/ large holes (5/16-24 UNF)	5.6/50 5.1/45 4.5/40 4.0/35	1/0-3 4-6 AWG 8 AWG 10-14 AWG	Cu	75°C
Neutral and ground bars small holes (10-32 UNF)	2.8/25 1.7/15	6-8 AWG 10-14 AWG	Cu	75°C
CTRL cable	0.2/1.77	18 AWG	—	75°C

 **NOTE:** Use copper wire only except where indicated.

Revision history

REVISION	DATE	DESCRIPTION
140-00271-09	August 2024	Updated the “Mounting the product” section.
	June 2024	<ul style="list-style-type: none">• UL compliance related changes.• Updated the “Backup loads wiring” section.
140-00271-08	December 2023	Updated SSD instructions.
140-00271-07	November 2023	Editorial updates.
140-00271-06	June 2023	<ul style="list-style-type: none">• Added “Power Control Systems (PCS)” section.• Added “Compatibility” section.• Updated CT wiring section.
140-00271-05	June 2023	<ul style="list-style-type: none">• Added “Specifications” section.• Added “Addendum A: Wire sizes and tightening torque” section.
140-00271-04	April 2023	<ul style="list-style-type: none">• Added “Control (CTRL) wiring between system components” section.• Editorial updates.
Previous releases.		

IQSC-3G-QIG-140-00271-09-EN-US-2024-08-08

© 2024 Enphase Energy. All rights reserved. Enphase, the e and CC logos, IQ, and certain other marks listed at <https://enphase.com/trademark-usage-guidelines> are trademarks of Enphase Energy, Inc. in the U.S. and other countries. Data subject to change.

