

Table of contents

Safety rules.....	4
Explanation of Safety Instructions.....	4
How information is presented in the document.....	4
General.....	4
Environmental conditions.....	5
Qualified personnel.....	5
Copyright.....	6
Data backup.....	6
FCC / RSS Compliance.....	6
Disposal.....	6
General.....	7
Device description.....	7
Information on the device.....	7
Positioning.....	7
Displays and connections.....	8
Installation.....	9
Installation Checklist.....	9
Mounting.....	9
Circuit Protection.....	10
Line Wiring.....	10
Connect Current Transformers.....	13
Power control systems (USA, Canada, Mexico).....	13
CT Wiring.....	14
Connecting data communication cables to inverters.....	14
Set the address of the Fronius Smart Meter.....	15
Terminating resistors - explanation of symbols.....	16
Terminating Resistors.....	16
Set Baud Rate.....	17
Multi meter system - Explanation of symbols.....	18
Modbus participant - Fronius SnapINverter.....	18
Multi meter system - Fronius SnapINverter.....	19
Modbus participant - Fronius GEN24.....	20
Multi meter system - Fronius GEN24 inverter.....	20
Commissioning	23
Fronius SnapINverter.....	25
General.....	25
Connect to Fronius Datamanager 2.0.....	25
Configure Fronius Smart Meter as primary meter.....	25
Configure Fronius Smart Meter as a secondary meter.....	26
Fronius GEN24 inverter.....	27
General.....	27
Installation with the browser.....	27
Configure Fronius Smart Meter as primary meter.....	28
Configure Fronius Smart Meter as a secondary meter.....	28
Operation.....	30
Power Status LEDs.....	30
Modbus Communication LEDs.....	31
Technical data.....	32
Accuracy.....	32
Measurement.....	32
Models and Electrical.....	32
Certifications.....	33
Environmental.....	34
Fronius manufacturer's warranty.....	34

Safety rules

Explanation of Safety Instructions

DANGER!

Indicates an immediate danger.

- ▶ Death or serious injury may result if appropriate precautions are not taken.
-

WARNING!

Indicates a possibly dangerous situation.

- ▶ Death or serious injury may result if appropriate precautions are not taken.
-

CAUTION!

Indicates a situation where damage or injury could occur.

- ▶ Minor injury or damage to property may result if appropriate precautions are not taken.
-

NOTE!

Indicates the possibility of flawed results and damage to the equipment.

How information is presented in the document

The conventions regarding how information is presented in the document, which are set out below, have been defined in order to increase the readability and comprehensibility of the document.

Application notes

IMPORTANT! Indicates application notes and other useful information. It does not indicate a harmful or dangerous situation.

Software

Software functions and elements of a graphical user interface (e.g., buttons, menu items) are highlighted in the text with this **mark up**.

Example: Click **Save**.

Instructions for action

1 Action steps are displayed with consecutive numbering.

- ✓ *This symbol indicates the result of the action step or the entire instruction.*

General

The device has been manufactured using state-of-the-art technology and according to recognized safety standards. If used incorrectly or misused, however, it can cause

- serious or fatal injury to the operator or a third party,
 - and damage to the device and other material assets belonging to the operating company.
-

All persons involved in start-up operation, maintenance and servicing of the device must

- be suitably qualified,
- have knowledge of and experience in dealing with electrical installations and
- have fully read and precisely followed these Operating Instructions.

The Operating Instructions must always be kept on hand wherever the device is being used. In addition to the Operating Instructions, all applicable local rules and regulations regarding accident prevention and environmental protection must also be followed.

All safety and danger notices on the device

- must be kept in a legible state
- must not be damaged/marked
- must not be removed
- must not be covered, pasted, or painted over.

The terminals can reach high temperatures.

Only operate the device when all protection devices are fully functional. If the protection devices are not fully functional, there is a risk of

- serious or fatal injury to the operator or a third party,
- and damage to the device and other material assets belonging to the operating company.

Any safety devices that are not functioning properly must be repaired by an authorized specialist before the device is switched on.

Never bypass or disable protection devices.

For the location of the safety and danger notices on the device, refer to the section headed "General" in the Operating Instructions for the device.

Any equipment malfunctions which might impair safety must be remedied immediately before the device is turned on.

Your personal safety is at stake!

Environmental conditions

Operation or storage of the device outside the stipulated area will be deemed as not in accordance with the intended purpose. The manufacturer accepts no liability for any damage resulting from improper use.

Qualified personnel

The information contained in these operating instructions is intended only for qualified personnel. An electric shock can be fatal. Do not carry out any actions other than those described in the documentation. This also applies to qualified personnel.

All cables must be secured, undamaged, insulated, and adequately dimensioned. Loose connections, damaged or under-dimensioned cables must be repaired immediately by an authorized specialist company.

Maintenance and repair work must only be carried out by an authorized specialist company.

It is impossible to guarantee that third-party parts are designed and manufactured to meet the demands made on them, or that they satisfy safety requirements. Only use original spare parts.

Do not carry out any alterations, installations, or modifications to the device without first obtaining the manufacturer's permission.

Replace any damaged components or have them replaced immediately.

Copyright

Copyright of these operating instructions remains with the manufacturer.

Text and illustrations were accurate at the time of printing, subject to change. We are grateful for suggestions for improvement and information on any discrepancies in the operating instructions.

Data backup

With regard to data security, the user is responsible for:

- backing up any changes made to the factory settings
 - saving and storing personal settings
-

FCC / RSS Compliance

FCC

This device corresponds to the limit values for a digital device of class B in accordance with Part 15 of the FCC regulations. The limit values should provide adequate protection against harmful interference in homes. This device creates and uses high frequency energy and can interfere with radio communications when not used in accordance with the instructions. However, there is no guarantee against interference occurring in a particular installation.

If this device interferes with radio or television reception when turning the device on and off, it is recommended that the user solve this with one or more of the following measures:

- adjust or reposition the receiving antenna
- increase the distance between the device and the receiver
- connect the device to another circuit, which does not include the receiver
- for further support, please contact the retailer or an experienced radio/TV technician.

Industry Canada RSS

The device corresponds to the license-free Industry Canada RSS standards. Operation is subject to the following conditions:

- (1) The device may not cause harmful interference
 - (2) The device must accept any interference received, including interference that may cause undesired operation.
-

Disposal

Waste electrical and electronic equipment must be collected separately and recycled in an environmentally sound manner in accordance with the European Directive and national law. Used equipment must be returned to the distributor or through a local authorized collection and disposal system. Proper disposal of the used device promotes sustainable recycling of resources and prevents negative effects on health and the environment.

Packaging materials

- Collect separately
- Observe local regulations
- Crush cardboard boxes

General

Device description

The Fronius Smart Meter is a bidirectional electricity meter for optimizing self-consumption and recording a household's load characteristic curve. Together with a Fronius inverter or Fronius Datamanager 2.0 and a Fronius data interface, the Fronius Smart Meter allows you to view your own power consumption. The meter measures the energy flow to the loads or to the public grid and forwards the information to the Fronius inverter or Fronius Datamanager 2.0 via the Modbus RTU/RS485 interface.

CAUTION!

Danger due to non-compliance with the safety instructions

Risk of injury and damage to the device as a result.

- ▶ Follow all safety instructions.
- ▶ Switch off the power supply before establishing the mains connection.

Information on the device

Safety symbols:



To avoid electric shocks:

- Do not dismantle or modify the device
- Do not allow any water to enter the device
- Do not allow any foreign substances or material to enter the device
- Do not touch any connections directly



RCM Symbol - The product complies with the Australian laws.

Positioning

The Fronius Smart Meter can be installed at two possible locations in the system, at the feed-in point and at the consumption point.

Positioning at the feed-in point

The positioning of the Fronius Smart Meter at the feed-in point.

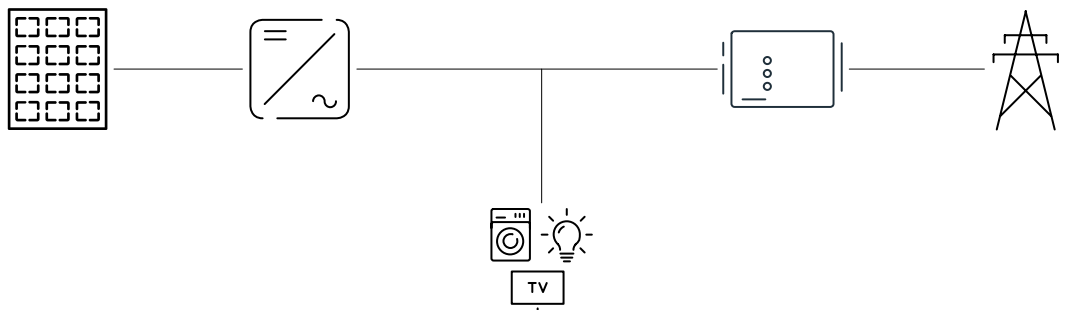

Positioning at the consumption point

The positioning of the Fronius Smart Meter at the consumption point.

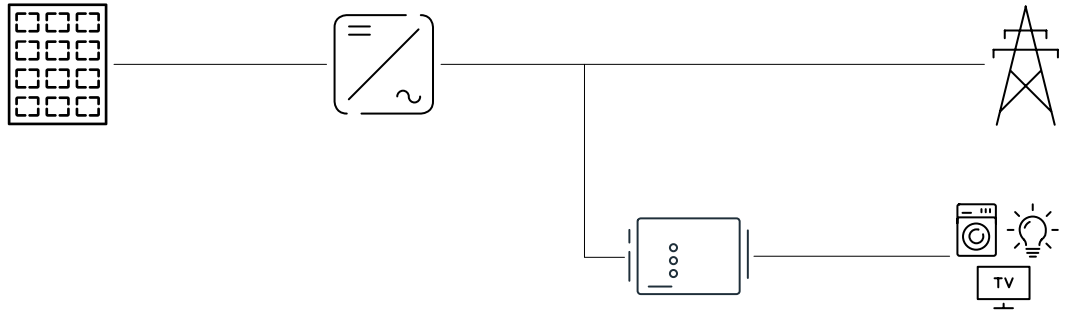

Displays and connections

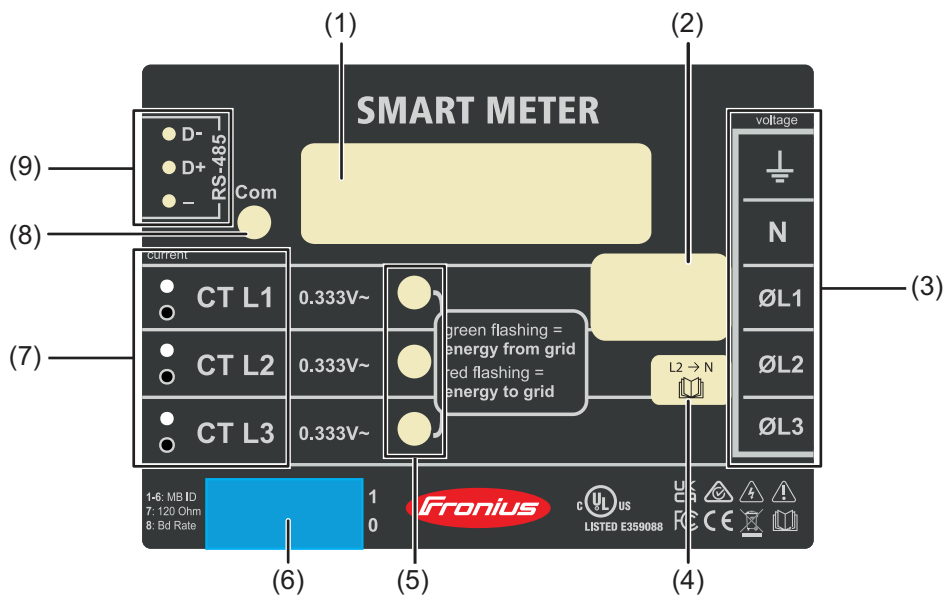

- (1) Product name
- (2) Nominal voltage, operating frequencies, measurement category
- (3) AC connection area
- (4) Note single-phase grids
- (5) Power status LED
 - green, flashing: Import of energy from public grid
 - red, flashing: Export of energy to the public grid
 - For further display options, see [Power Status LEDs](#)
- (6) DIP-switch:
 - set modbus adress, see [Set the address of the Fronius Smart Meter](#)
 - set terminating resistor, see [Terminating Resistors](#)
 - set Baud Rate, see [Set Baud Rate](#)
- (7) CT connection area
- (8) Data communication LED
- (9) Data communication connection area

Installation

Installation Checklist

See the sections referenced below for installation details.

- 1** Turn off power before making line voltage connections.
- 2** Mount the Fronius Smart Meter (see [Mounting](#) on page 9).
- 3** Connect circuit breakers or fuses and disconnects (see [Circuit Protection](#) on page 10).
- 4** Connect the line voltage wires to the meter's terminal block (see [Line Wiring](#) on page 10).
- 5** Mount the Current Transformers (CTs) around the line conductors. Make sure the CTs face the correct direction. An arrow might indicate either the load or the source (public grid) (see [Connect Current Transformers](#) on page 13).
- 6** Connect the twisted white and black wires from the CTs to the terminal block on the meter, matching the wire colors to the white and black dots on the meter label (see [CT Wiring](#) on page 14).
- 7** Check that the CT phases match the line voltage phases (see [Connect Current Transformers](#) on page 13).
- 8** Record the CT rated current for each meter, because it will be required during setup.
- 9** Connect the output terminals of the Fronius Smart Meter to the monitoring equipment (see [Connecting data communication cables to inverters](#) on page 14).
- 10** If necessary set terminating resistors (see [Terminating Resistors](#) on page 16).
- 11** Check that all the wires and plugs are securely installed in the terminal blocks by tugging on each wire.
- 12** Turn on the power to the Smart Meter.
- 13** Verify that the LEDs indicate correct operation. If there is a consumption of power and all generated power sources are turned off, then the LEDs from the used phases should flash green (see [Power Status LEDs](#) on page 30).
- 14** Check your Fronius System monitoring software. In order to ensure compatibility between the inverter and the Smart Meter, software must always be kept up-to-date. The update can be started via the inverter website or via Solar.web.
- 15** Set CT-Ratio and Grid Type on the web interface of the Fronius Datamanager in Settings - Meter - Settings (see [Commissioning](#) on page 23).

Mounting

The Fronius Smart meter has two mounting holes spaced 5.4 in. (137 mm) apart (center-to-center). These mounting holes are normally obscured by the detachable screw terminals. Remove the screw terminals to mark the hole positions and mount the meter.

Self-tapping sheet metal screws are included. Do not over-tighten the screws, as long-term stress on the case can cause cracking.

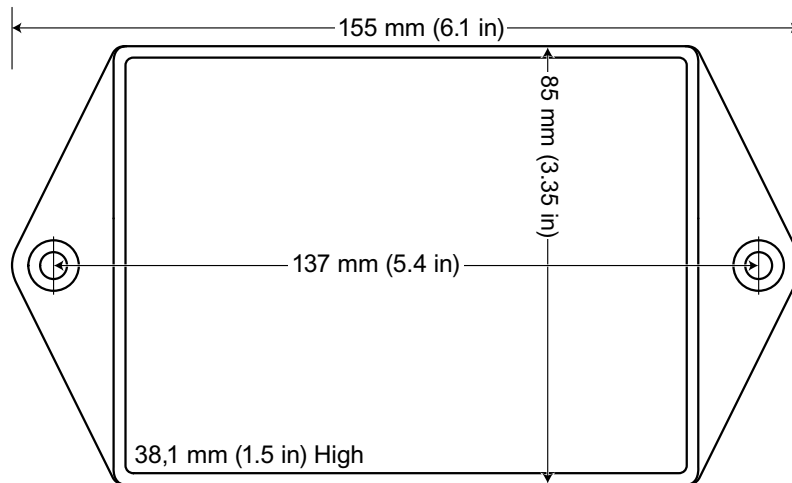

Circuit Protection

The Fronius Smart Meter is considered “permanently connected equipment” and requires a disconnect means (circuit breaker, switch or disconnect) and overcurrent protection (fuse or circuit breaker).

The Fronius Smart Meter only draws 10-30 mA, so the rating of any switches, disconnects, fuses and / or circuit breakers is determined by the wire gauge, the mains voltage and the current interrupting rating required.

- The switch, disconnect or circuit breaker must be within sight and as close as practicable to the Fronius Smart Meter and must be easy to operate.
- Use circuit breakers or fuses rated for 20 amps or less.
- Use ganged circuit breakers when monitoring more than one line voltage.
- The circuit breakers or fuses must protect the mains terminals labeled L1, L2 and L3. In the rare cases where neutral has overcurrent protection, the overcurrent protection device must interrupt both neutral and ungrounded conductors simultaneously.
- The circuit protection / disconnect system must meet IEC 60947-1 and IEC 60947-3, as well as all national and local electrical codes.

Line Wiring

- Always turn off power before connecting the line voltage inputs to the Fronius Smart Meter.
- For the line voltage wires, 16 to 12 AWG stranded wire, type THHN, MTW or THWN, 600 V are recommended.
- Do not place more than one wire per screw terminal; use separate wire nuts or terminal blocks if needed.
- Verify that the line voltages match the line-to-line and line-to-neutral values printed in the white box on the front label.

Connect each conductor to the appropriate phase; also connect ground and neutral (if applicable). The neutral connection “N” is not required on delta models but we recommend connecting it to ground if neutral is not present.

The screw terminal can handle wire up to 12 AWG. Connect each voltage line to the green terminal block as shown in the following figures. After the voltage lines have been connected, make sure both terminal blocks are fully seated in the Fronius Smart Meter.

When power is first applied, check that the LEDs behave normally. If you see LEDs flashing red-green-red-green, the voltage is too high for this model, so disconnect the power switch immediately!

Single-Phase Three-Wire (Mid-Point Neutral) / Two-Phase Australia

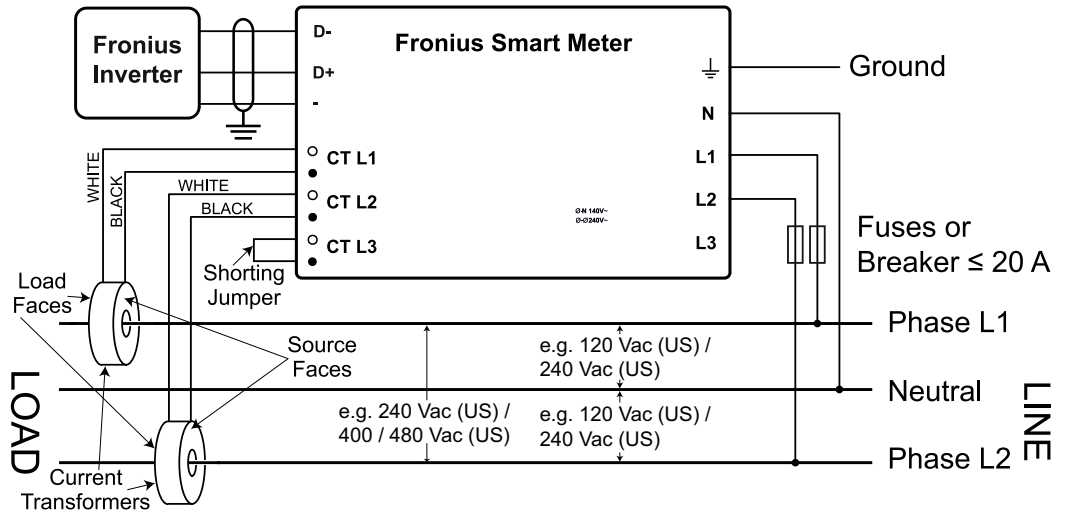

Single-Phase Two-Wire without Neutral

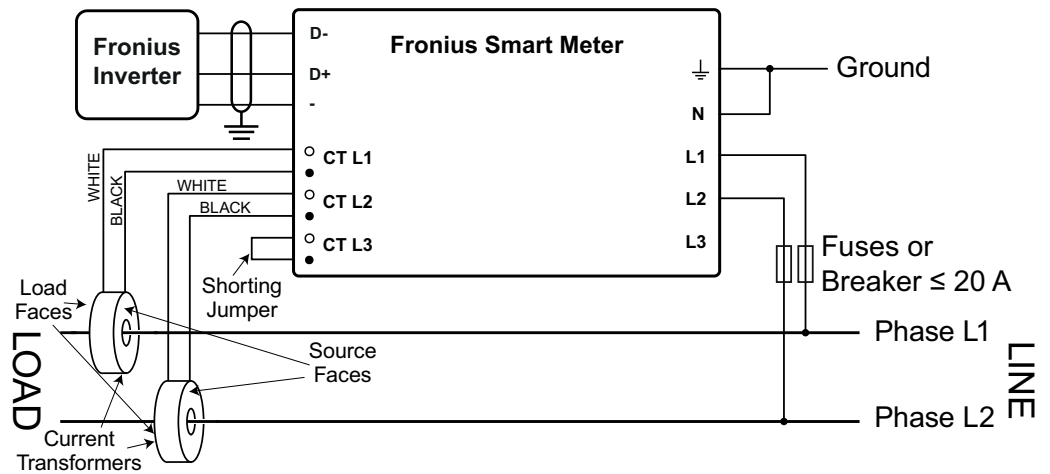

Single-Phase Two-Wire with Neutral

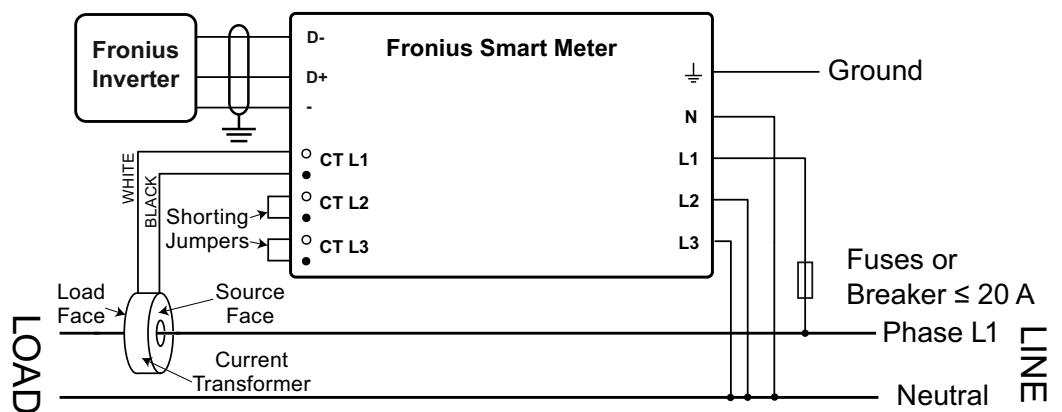

Three-Phase Four-Wire Wye

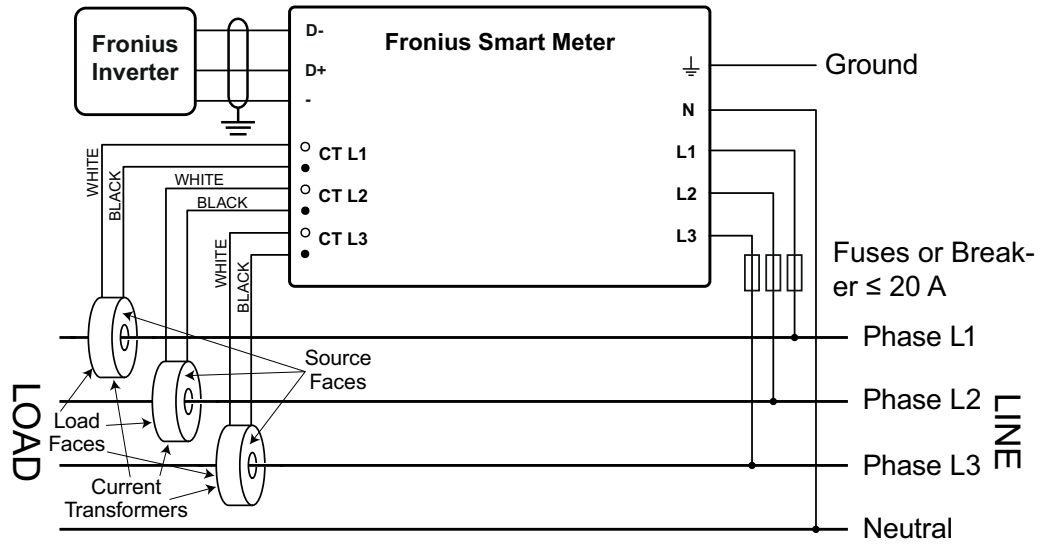

Three-Phase Three-Wire Delta without Neutral

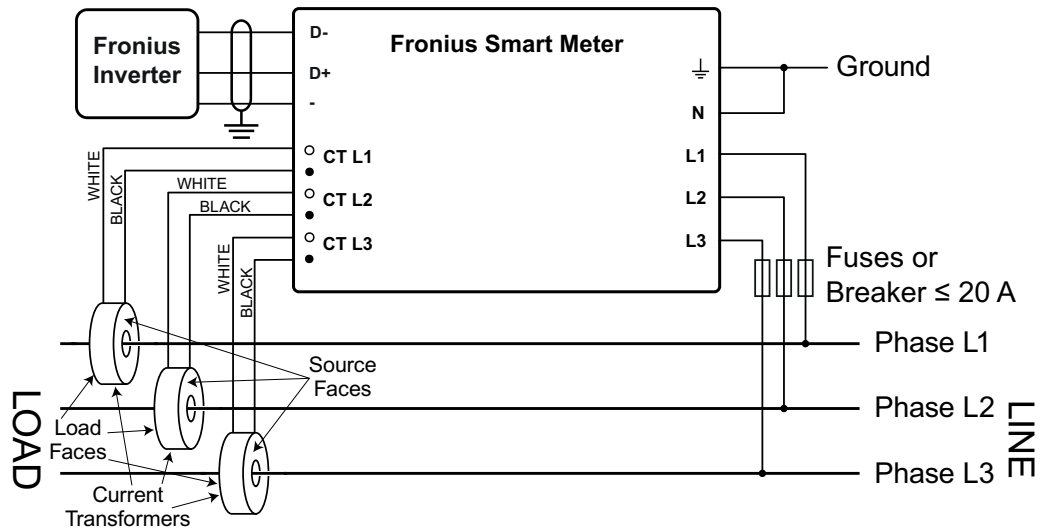

Three-Phase Four-Wire Stinger

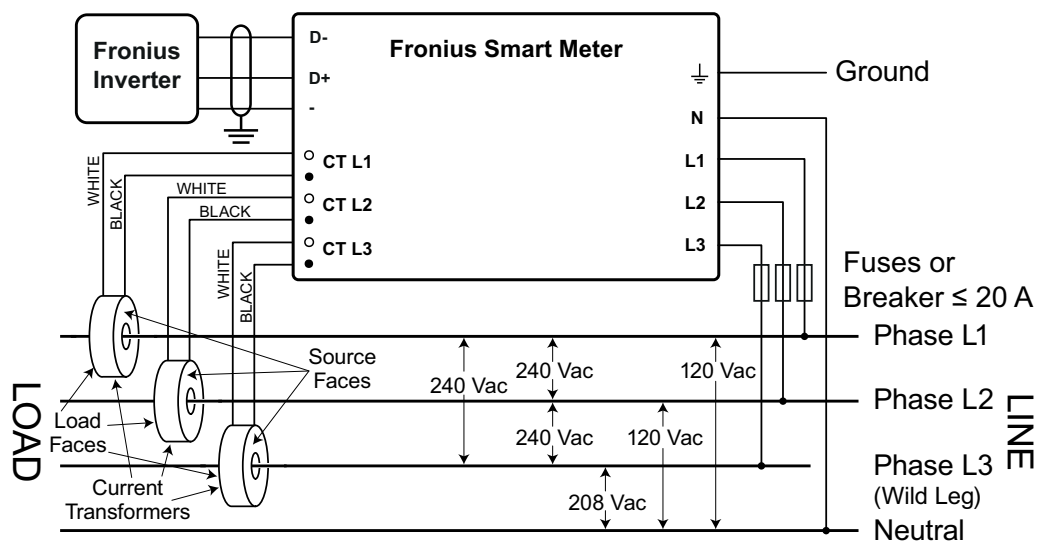

Three-Phase Two-Wire Corner Grounded Delta

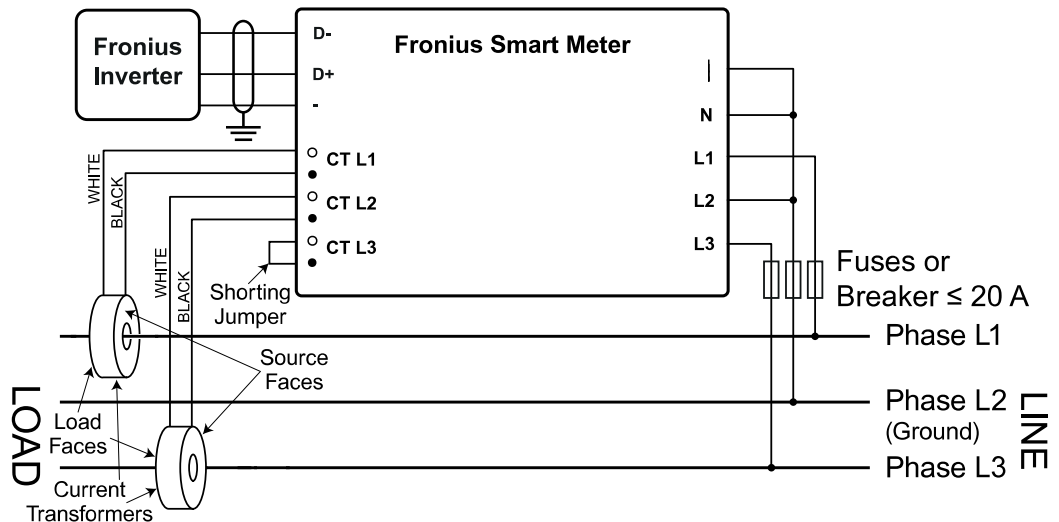

Connect Current Transformers

The current transformer must generate 333.33 millivolts AC at rated current. See the current transformer data sheets for CT ratings (Fronius CT, 41,0010,0104 / 41,0010,0105 / 41,0010,0232).

- Do not use ratio or current output such as 1 amp or 5 amp output models!
- See the CT data sheets for the maximum input current ratings.
- Be careful to match the CTs with the voltage phases. Make sure the CT L1 is measuring the current on the same phase being monitored by the L1 voltage input and the same for phases L2 and L3. Use the supplied colored labels or colored tape to identify the CT leads.
- To minimize current measurement noise, avoid extending the CT wires, especially in noisy environments. If it is necessary to extend the wires, use twisted pair cable 22 to 14 AWG, rated for 300 V or 600 V (not less than the service voltage) and shielded if possible
- Make sure the CTs face the correct direction. An arrow might indicate either the load or the source (public grid)
- If you see strange readings on unused phases, jumper the unused CT inputs: for each unused CT, connect a short cable from the terminal marked with a white dot to the terminal marked with a black dot.

Install the CTs around the conductor to be measured and connect the CT leads to the Fronius Smart Meter. Always turn off power before disconnecting any live conductors. Put the line conductors through the CTs as shown in the previous section.

CTs are directional. If they are mounted backwards or with their white and black wires swapped the measured power will be negative. The status LEDs indicate negative measured power by flashing red.

Split-core CTs can be opened for installation around the conductor. A nylon cable tie may be secured around the CT to prevent inadvertent opening.

Power control systems (USA, Canada, Mexico)

The device can be used for power control systems in accordance with the UL 3141 standard. The additionally required current transformers must comply with the specifications of the UL 2808 standard.

NOTE!

Power Control Systems

Power Control Systems according to UL 3141 are only available for installations in the USA, Canada and Mexico.

CT Wiring

The current transformers connect to the six position black screw terminal block. Connect the white and black CT wires to the Fronius Smart Meter terminals marked CT L1, CT L2 and CT L3. Excess length may be trimmed from the wires if desired. Connect each CT with the white wire aligned with the white dot on the label and the black wire aligned with the black dot. Note the order in which the phases are connected, as the line voltage phases must match the current phases for accurate power measurement.

Connecting data communication cables to inverters

Fronius SnapINverter:

Connect the data communication ports of the Fronius Smart Meter to the Fronius system monitoring in the inverter. Several Smart Meters can be installed in the system, see chapter [Multi meter system - Fronius SnapINverter](#) on page 19

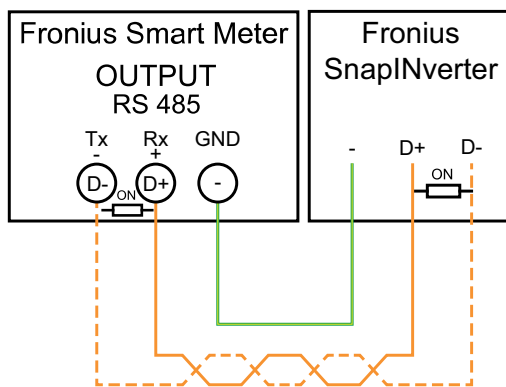

- 1 Connect **D-** to **D-**.
- 2 Connect **D+** to **D+**.
- 3 Connect **-** to **-**.

Fronius GEN24 inverter:

Connect the data communication ports of the Fronius Smart Meter to the Modbus interface of the Fronius GEN24 inverter. Several Smart Meters can be installed in the system, see chapter [Multi meter system - Fronius GEN24 inverter](#) on page 20

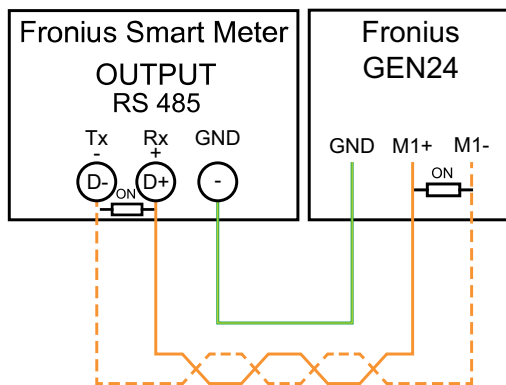

- 1 Connect **D-** to **M1-**.
- 2 Connect **D+** to **M1+**.
- 3 Connect **-** to **GND**.

IMPORTANT! Further information on successful start-up.

Observe the following information on connecting the data communication line to the inverter.

- Use a CAT5 type cable or higher.
- For data lines belonging together (D+, D- and M1+, M1-) use a twisted pair of cables.
- If the output cables are close to the mains wiring, use wires or cables rated at 300 V to 600 V (never less than the operating voltage).
- Use double insulated or sheathed output cables when near bare conductors.
- Use shielded twisted pair cables to avoid interference.
- The outputs of the Fronius Smart Meter are galvanically isolated from dangerous voltages.

Set the address of the Fronius Smart Meter

The Fronius Smart Meter must be connected to the Fronius Datamanager. If only one Fronius Smart Meter is installed, the Modbus Address is 1.

DIP Switch	1	2	3	4	5	6	7	8
Up (1) value	1	2	4	8	16	32	R 120 Ohm	Baud Rate

Examples

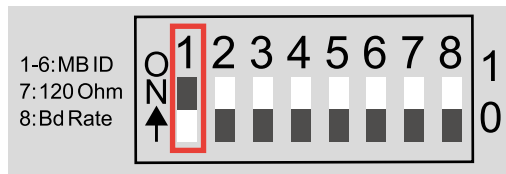

Modbus Adress 1

DIP Switch	1	2	3	4	5	6
Position	1	0	0	0	0	0

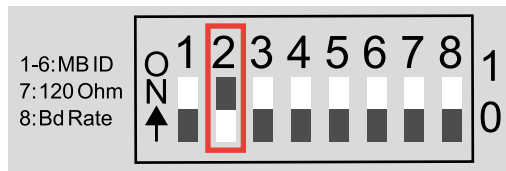

Modbus Adress 2

DIP Switch	1	2	3	4	5	6
Position	0	1	0	0	0	0

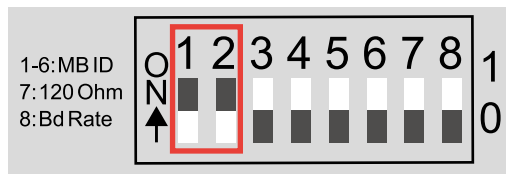

Modbus Adress 3 (value 1 + 2 = 3)

DIP Switch	1	2	3	4	5	6
Position	1	1	0	0	0	0

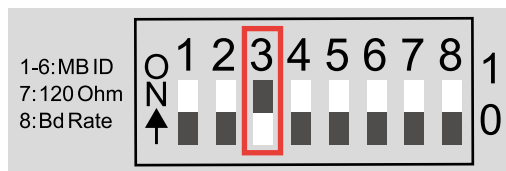

Modbus Adress 4

DIP Switch	1	2	3	4	5	6
Position	0	0	1	0	0	0

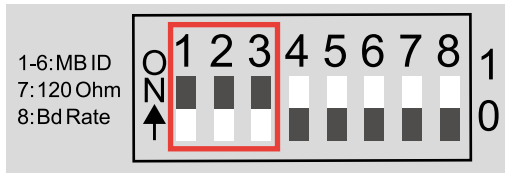

Modbus Adress 7 (value $1 + 2 + 4 = 7$)

DIP Switch	1	2	3	4	5	6
Position	1	1	1	0	0	0

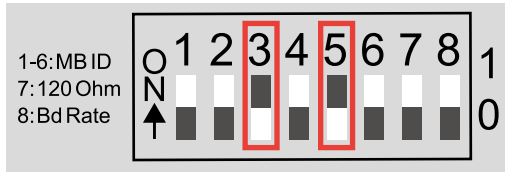

Modbus Adress 20 (value $4 + 16 = 20$)

DIP Switch	1	2	3	4	5	6
Position	0	0	1	0	1	0

Terminating resistors - explanation of symbols



Inverter in the system

e.g. Fronius Primo GEN24 208-240



Meter - Fronius Smart Meter WR

Terminating resistor is integrated in the meter.



Fronius or third-party device, connection via Modbus RTU

e.g. Fronius Ohmpilot, battery, etc.



Termination resistance

R 120 Ohm

Terminating Resistors

The system might work without terminating resistors. Due to interferences, the use of terminating resistors according to the following schemes are recommended.

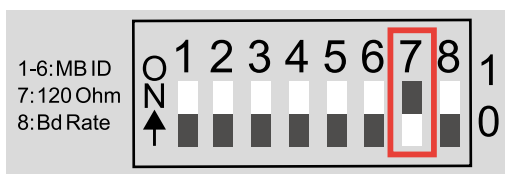

Activate the Fronius Smart Meter terminating resistor (R 120 Ohm) by switching pin 7 to ON (1).

OPTION 1

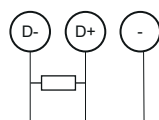

Manufacturer manual

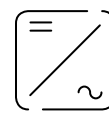
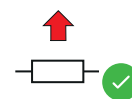
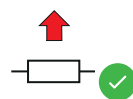

max. 300 m

OPTION 2

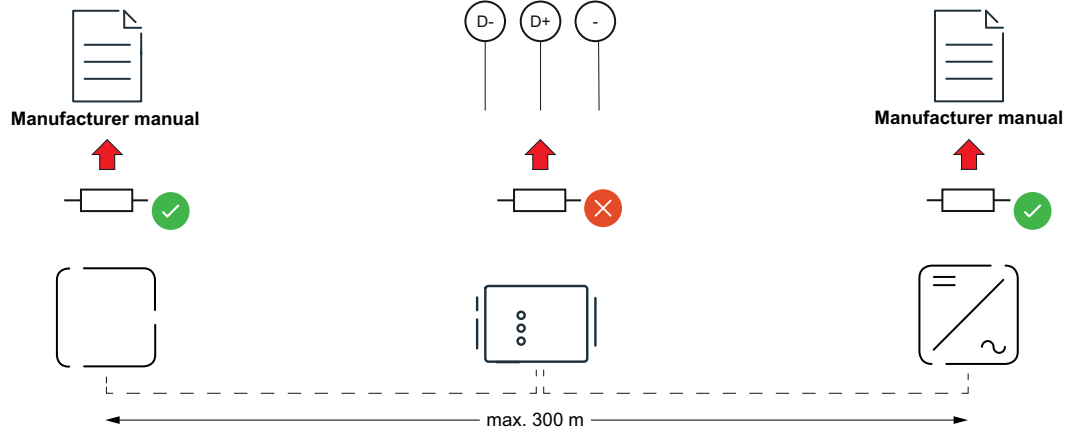

OPTION 3

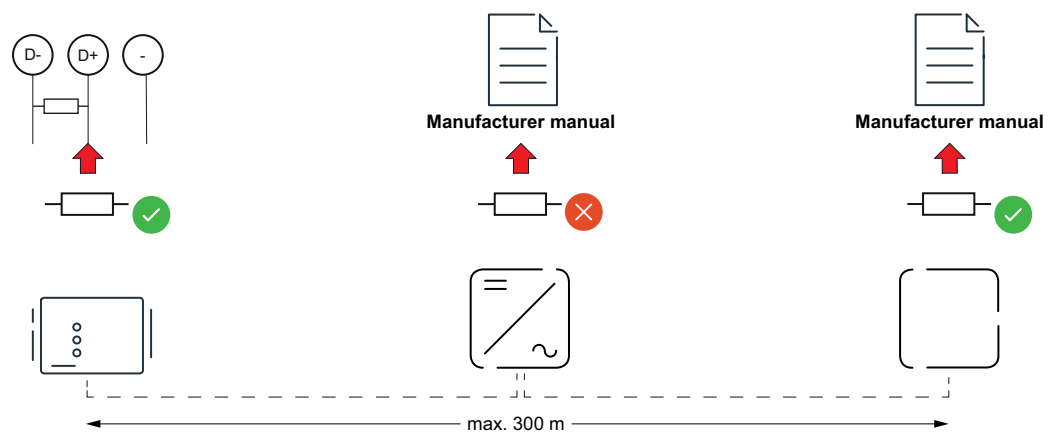

OPTION 4

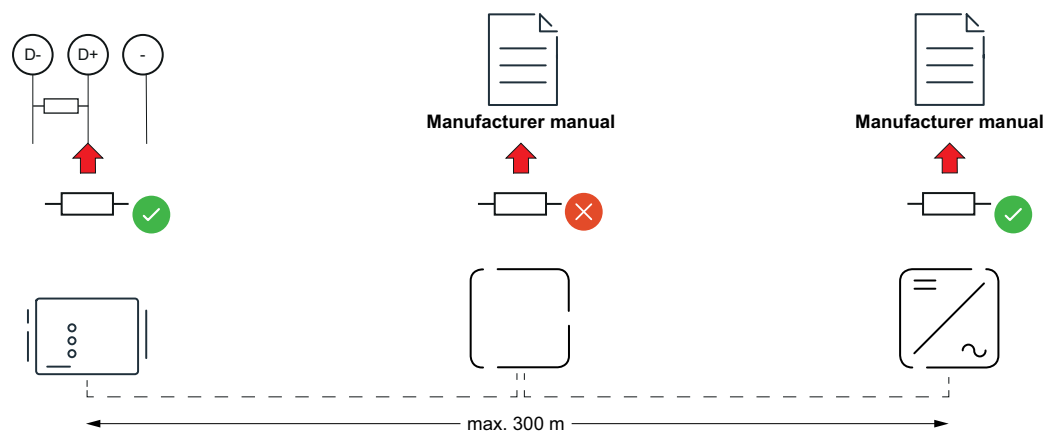

Set Baud Rate

Select the baud rate by setting DIP switch position 8 (see below). The change will take effect immediately.

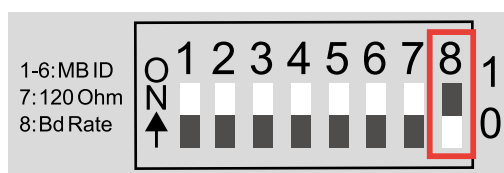

Baud Rate	DIP Switch 8
9600 (default)	0 (OFF)
38400	1 (ON)

Multi meter system - Explanation of symbols



Grid

Supplies the loads in the system if insufficient power is being generated by the PV modules or supplied by the battery.



Inverter in the system

e.g. Fronius Primo, Fronius Symo, etc.



Utility meter

Measures the metering data relevant for the billing of electricity quantities (primarily the kilowatt hours of grid purchases and grid power feed). On the basis of the data relevant for billing, the electricity retailer invoices a grid purchase and the purchaser of the surplus pays for the grid power feed.



Primary meter

Records the load curve of the system and makes the measured data available for energy profiling in Fronius Solar.web. The primary meter also regulates the dynamic feed-in control.



Secondary meter

Records the load curve of individual loads and producers (e.g. washing machine, lights, television, heat pump, etc.) in the consumption branch and makes the measured data available for energy profiling in Fronius Solar.web.



Modbus RTU, Third-party device

e.g. Fronius Ohmpilot, battery, etc.



Loads in the system

e.g. washing machine, lamps, TV, etc.



Additional loads in the system

e.g. heat pump



Additional producers in the system

e.g. wind power plant



Terminating resistor

R 120 Ohm

Modbus participant - Fronius SnapINverter

A maximum of 4 Modbus stations can be connected to the Modbus connection terminal.

IMPORTANT!

Only one primary meter, one battery and one Ohmpilot can be connected per inverter. Due to the high data transfer of the battery, the battery occupies 2 subscribers.

Example:

Input	Battery	Fronius Ohmpilot	Number of primary meters	Number of secondary meters
Modbus	✓	✓	1	0
	✓	✗	1	1
	✗	✓	1	2
	✗	✗	1	3

Multi meter system - Fronius SnapINverter

If several Fronius Smart Meters are installed, a separate address must be set for each one (see [Set the address of the Fronius Smart Meter](#) on page 15). The primary meter always receives the address 1. All other meters are numbered consecutively in the address range from 2 to 14. Different Fronius Smart Meter power categories can be used together.

IMPORTANT!

Use no more than 3 secondary meters in the system. To avoid interference, it is recommended to install the terminating resistors according to the chapter [Terminating Resistors](#) on page 16.

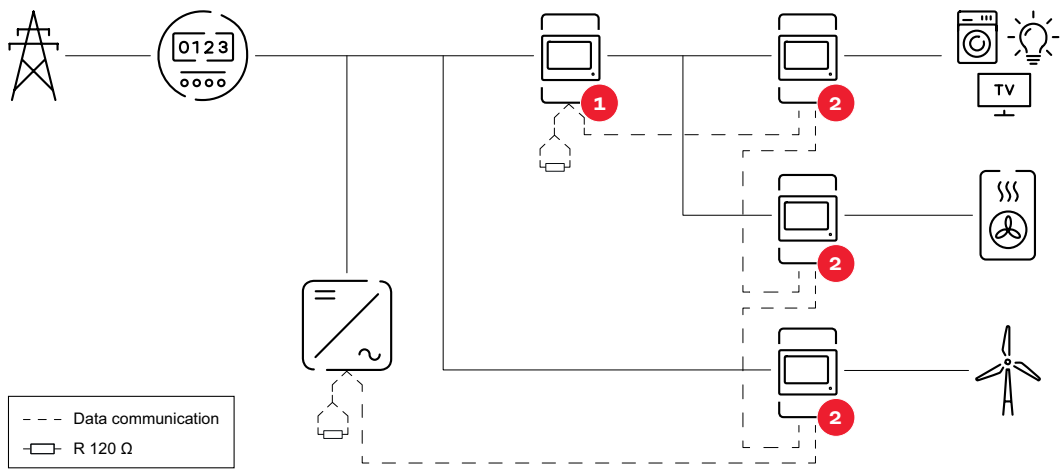

Position of the primary meter in the consumption branch. *Termination resistor R 120 Ohm

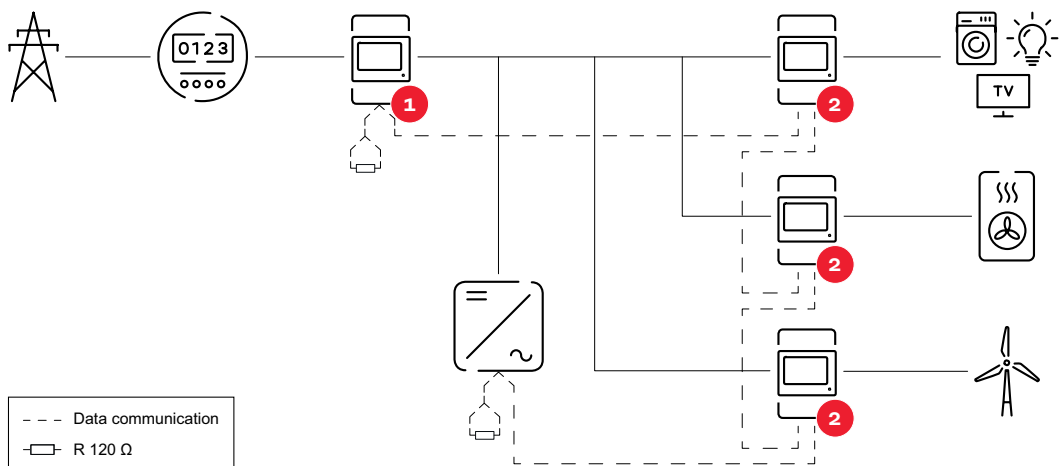

Position of the primary meter at the feed-in point. *Termination resistor R 120 Ohm

The following must be observed in a multi meter system:

- Each Modbus address is assigned only once.
- Place the terminating resistors individually for each channel.

Modbus participant - Fronius GEN24

The inputs MO and M1 can be freely selected. A maximum of 4 Modbus participants can be connected to the Modbus terminal on the inputs MO and M1.

IMPORTANT!

Only one primary meter, one battery and one Ohmpilot can be connected per inverter. Due to the high data transfer of the battery, the battery occupies 2 subscribers.

Example 1:

Input	Battery	Fronius Ohmpilot	Number of primary meters	Number of secondary meters
Modbus 0 (MO)	✗	✗	0	4
	✓	✗	0	2
	✓	✓	0	1
Modbus 1 (M1)	✗	✗	1	3

Example 2:

Input	Battery	Fronius Ohmpilot	Number of primary meters	Number of secondary meters
Modbus 0 (MO)	✗	✗	1	3
Modbus 1 (M1)	✗	✗	0	4
	✓	✗	0	2
	✓	✓	0	1

Multi meter system - Fronius GEN24 inverter

If several Fronius Smart Meters are installed, a separate address must be set for each one (see [Set the address of the Fronius Smart Meter](#) on page 15). The primary meter always receives the address 1. All other meters are numbered consecutively in the address range from 2 to 14. Different Fronius Smart Meter power categories can be used together.

IMPORTANT!

Use no more than Use 7 secondary meters in the system. To avoid interference, it

is recommended to install the terminating resistors according to the chapter **Terminating Resistors** on page 16.

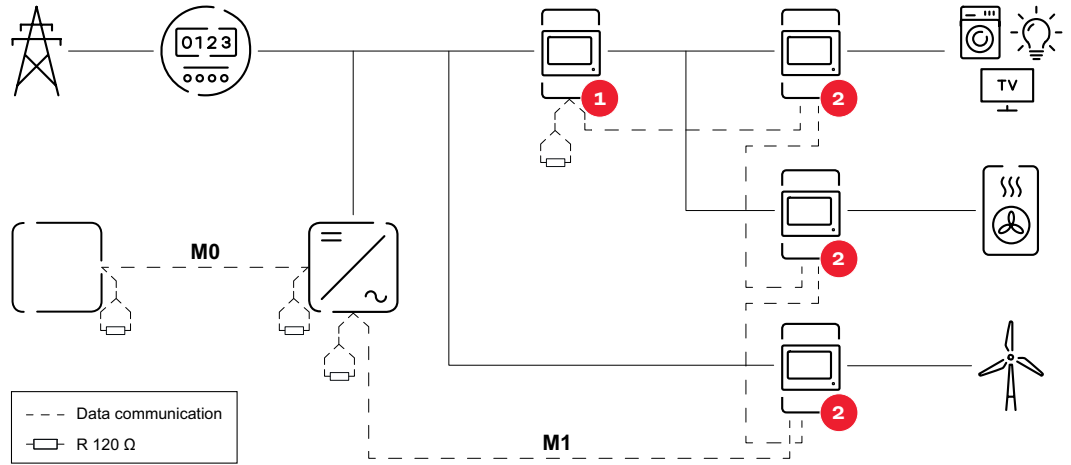

Position of the primary meter in the consumption branch. *Termination resistance R 120 Ohm

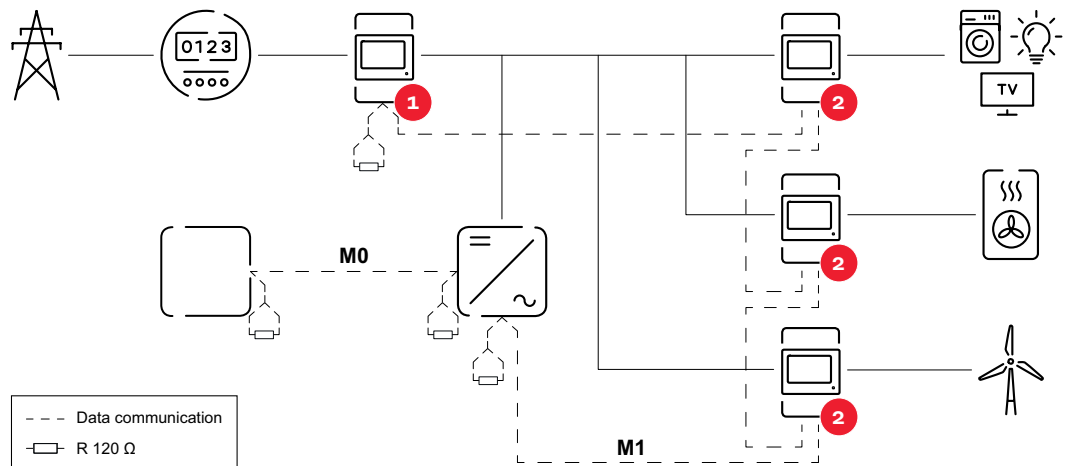

Position of the primary meter at the feed-in point. *Termination resistance R 120 Ohm

The following must be observed in a multi meter system:

- Connect the primary meter and the battery to different channels (recommended).
- Distribute the remaining Modbus participants evenly.
- Each Modbus address is assigned only once.
- Place the terminating resistors individually for each channel.

Commissioning

Fronius SnapINverter

General

IMPORTANT! Settings in the "Meter" menu item may only be entered by staff trained to do so!

The service password must be entered for the "Meter" menu item.

Three-phase or one-phase Fronius Smart Meters may be used. In both cases, selection is made via the "Fronius Smart Meter" item. The Fronius Datamanager automatically detects the meter type.

One primary meter and several secondary meters can be selected. The primary meter must be configured before a secondary meter can be chosen.

Connect to Fronius Datamanager 2.0

Access Point:

Activate the WiFi access point of the inverter:

- 1 Select the **Setup** menu on the inverter display.
- 2 Navigate to **WiFi Access Point**.
 - ✓ *Network (SS) and password (PW) are displayed.*
- 3 Activate the **WiFi Access Point** with the Enter ↵ key.

Establish the connection from the inverter's WiFi access point to the PC:

- 1 Establish the connection to the inverter in the network settings (the inverter is displayed with the name "Fronius_240.XXXXXX").
 - 2 Enter and confirm the password from the inverter display.
 - 3 In the browser's address bar, enter the IP address <http://192.168.250.181> and confirm.
- ✓ *The Fronius Datamanager 2.0 start page is displayed.*
-

LAN:

- 1 Connect the Fronius Datamanager and computer with a LAN cable.
 - 2 Place the Fronius Datamanager 2.0 IP switch in the "A" position.
 - 3 In the browser's address bar, enter the IP address <http://169.254.0.180> and confirm.
-

Configure Fronius Smart Meter as primary meter

- 1 Call up the Fronius Datamanager 2.0 website.
 - Open web browser.
 - In the browser's address bar, enter the IP address (IP address for WLAN: 192.168.250.181, IP address for LAN: 169.254.0.180) or enter and confirm the host and domain name of the Fronius Datamanager 2.0.
 - The Fronius Datamanager 2.0 website appears.
- 2 Click on the **Settings** button.
- 3 Log in to the login area with user **Service** and the service password.
- 4 Call up the **Meter** menu area.
- 5 Select the primary meter from the drop-down list.
- 6 Click on the **Settings** button.

- 7 Set the meter position of the meter (feed-in point or consumption point) in the pop-up window. For more information on the position of the Fronius Smart Meter, see [Positioning](#) on page 7.
- 8 Set the converter ratio and the network type.
- 9 Click the **OK** button when the status OK is displayed. If the *timeout* status is displayed, repeat the operation.
- 10 Click on the button ✓ to save the settings.

The Fronius Smart Meter is configured as a primary meter.

In the menu area **Current Total View**, the power of the PV modules, the self-consumption, the grid power feed and battery charging (if available) are displayed.

Configure Fronius Smart Meter as a secondary meter

- 1 Call up the Fronius Datamanager 2.0 website.
 - Open web browser.
 - In the browser's address bar, enter the IP address (IP address for WLAN: 192.168.250.181, IP address for LAN: 169.254.0.180) or enter and confirm the host and domain name of the Fronius Datamanager 2.0.
 - The Fronius Datamanager 2.0 website appears.
- 2 Click on the **Settings** button.
- 3 Log in to the login area with user **Service** and the service password.
- 4 Call up the **Meter** menu area.
- 5 Select the secondary meter from the drop-down list.
- 6 Click on the **Add** button.
- 7 Enter the name of the secondary meter in the **Name** input field.
- 8 Enter the previously assigned address in the **Modbus address** input field.
- 9 Set the converter ratio and the network type.
- 10 Complete the description of the meter.
- 11 Click on the button ✓ to save the settings.

The Fronius Smart Meter is configured as a secondary meter.

Fronius GEN24 inverter

General

IMPORTANT! Settings in the "Device configuration" menu item may only be entered by staff trained to do so!

The service password must be entered for the "Device configuration" menu item.

Three-phase or one-phase Fronius Smart Meters may be used. In both cases, selection is made via the "Components" menu area. The meter type is determined automatically.

One primary meter and several secondary meters can be selected. The primary meter must be configured before a secondary meter can be chosen.

Installation with the browser

WLAN:

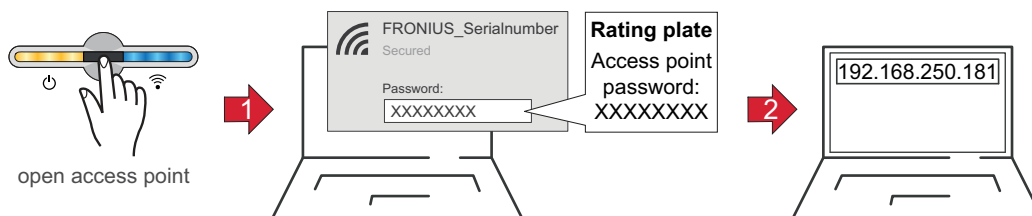

- 1 Open the access point by touching the sensor 
✓ *Communications LED flashes blue.*
- 2 Establish the connection to the inverter in the network settings (the inverter is displayed with the name "FRONIUS_" and the serial number of the device).
- 3 Enter the password from the rating plate and confirm.
IMPORTANT!
To enter the password in Windows 10, first select the **Connect using a security key instead** link to be able to establish the connection with the password.
- 4 Enter the IP address 192.168.250.181 in the address bar of the browser and confirm. The installation wizard opens.
- 5 Follow the installation wizard and complete the installation in the individual areas.
- 6 Add the system components in Fronius Solar.web and commission the PV system.

The network wizard and product setup can be performed independently. A network connection is required for the Fronius Solar.web installation wizard.

Ethernet:

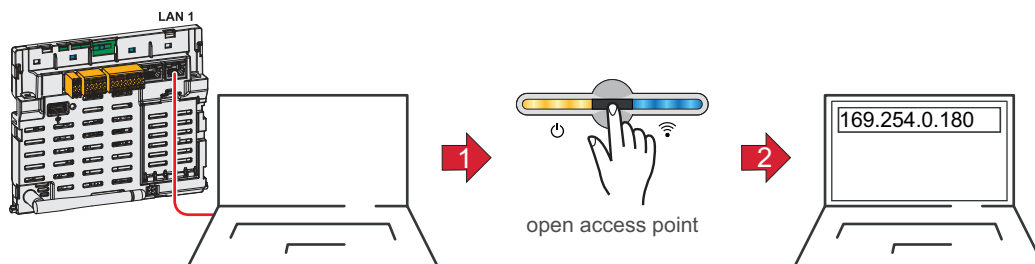

- 1 Establish a connection to the inverter (LAN1) using a network cable (min. CAT5 STP).
- 2 Open the access point by touching the sensor once 
 - ✓ *Communications LED flashes blue.*
- 3 Enter the IP address 169.254.0.180 in the address bar of the browser and confirm. The installation wizard opens.
- 4 Follow the installation wizard and complete the installation in the individual areas.
- 5 Add the system components in Fronius Solar.web and commission the PV system.

The network wizard and product setup can be performed independently. A network connection is required for the Fronius Solar.web installation wizard.

Configure Fronius Smart Meter as primary meter

- 1 Call up the website of the inverter.
 - Open web browser.
 - In the browser's address bar, enter the IP address (IP address for WLAN: 192.168.250.181, IP address for LAN: 169.254.0.180) or enter and confirm the host and domain name of the inverter.
 - The website of the inverter is displayed.
- 2 Click on the **Device configuration** button.
- 3 Log in to the login area with user **Technician** and the technician password.
- 4 Call up the **Components** menu area.
- 5 Click on the **Add components** button.
- 6 Set the position of the meter (feed-in point or consumption point) in the **Position** drop-down list. For more information on the position of the Fronius Smart Meter, see [Positioning](#) on page 7.
- 7 Set the converter ratio and the network type.
- 8 Click on the **Add** button.
- 9 Click the **Save** button to save the settings.

The Fronius Smart Meter is configured as a primary meter.

Configure Fronius Smart Meter as a secondary meter

- 1 Call up the website of the inverter.
 - Open web browser.
 - In the browser's address bar, enter the IP address (IP address for WLAN: 192.168.250.181, IP address for LAN: 169.254.0.180) or enter and confirm the host and domain name of the inverter.
 - The website of the inverter is displayed.
- 2 Click on the **Device configuration** button.
- 3 Log in to the login area with user **Technician** and the technician password.
- 4 Call up the **Components** menu area.
- 5 Click on the **Add components** button.
- 6 Select the meter type (generator meter/load meter) in the **Position** drop-down list.
- 7 Enter the previously assigned address in the **Modbus address** input field.
- 8 Enter the name of the meter in the **Name** input field.
- 9 Set the converter ratio and the network type.
- 10 Select the category (generator or load) in the **Category** drop-down list.

11 Click on the **Add** button.

12 Click the **Save** button to save the settings.

The Fronius Smart Meter is configured as a secondary meter.

Operation

Power Status LEDs

The three status LEDs on the front of the Fronius Smart Meter can help indicate correct measurements and operation. The "L1", "L2", and "L3" on the diagrams indicate the three phases:

Normal Startup

The Fronius Smart Meter displays the following startup sequence whenever power is first applied.

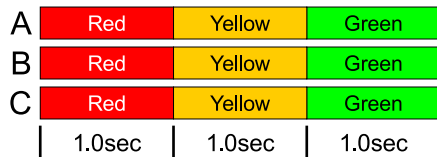

Consuming Power

Any phase with the LEDs flashing green is indicating normal positive power (Import of energy from public grid).

If the inverter or any other power source is not producing power and some minimal power is being used, the LEDs should be flashing green. This is normal, when the inverter is in its 5 minute startup cycle.

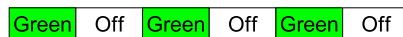

No Power

Any phase with a solid green LED indicates no power, but line voltage is present.



No Voltage

Any phase LED that is off indicates no voltage on that phase.

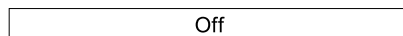

Generating Power

Red flashing indicates negative power for that phase. This is a normal behavior if more power is produced (by the inverter or any other power source) than consumed (Export of energy to the public grid). If no power is produced at all, this might indicate either reversed CT's, swapped CT wires or CT's are not matched with the correct line voltage phase.



Overvoltage Warning

The following indicates that the line voltage is too high for this model. Disconnect power immediately! Check the line voltages and the meter ratings (in the white box on the label).

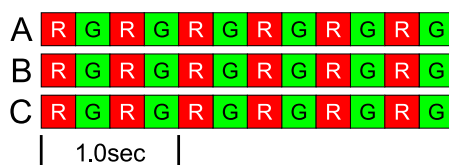

Meter Not Operating

If none of the LEDs are illuminated, check that the correct line voltages are ap-

plied to the meter. If the voltages are correct, call customer service for assistance.

A	Off
B	Off
C	Off

Error

If the meter experiences an internal error, all LEDs will light up red for 3 or more seconds. If you see this happen repeatedly, call customer service for assistance.

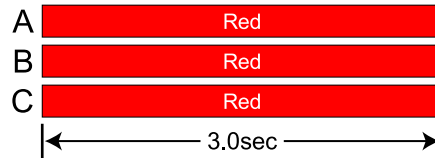

Modbus Communication LEDs

Near the upper left corner, there is a diagnostic Com (communication) LED that can indicate the following:

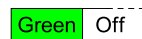

A short green flash indicates a valid packet addressed to this device.

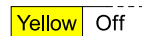

Short yellow flashes or rapid flashing indicate valid packets addressed to different devices.



A one-second red flash indicates an invalid packet: bad baud rate, bad CRC, noise, bad parity, etc.



Rapid red/yellow flashing indicates a possible address conflict (two devices with the same DIP switch address).



Solid red indicates the address is set to zero: an invalid choice.

Technical data

Accuracy

Normal Operation

Line voltage: 90 - 347 Vac (Line to Neutral), 120 - 600 Vac (Line to Line)

Power factor: 1.0

Frequency: 45 - 65 Hz

Ambient Temperature: 23° C ± 5° C

CT Current: 5% - 100% of rated current

Accuracy: ± 0.5% of reading

Measurement

Update Rate: 0.1 second. Internally, all measurements are performed at this rate.

Startup Time: ~1.0 second. The Fronius Smart Meter starts communicating this long after AC voltage is applied. Energy measurement starts 50-100 milliseconds after AC is applied.

Default CT Phase Angle Correction: 0.0 degrees.

Models and Electrical

Meter Service Type	Nominal Vac Line-to-Neutral	Nominal Vac Line-to-Line	Phases	Wires
WR	90-347	120-600	1 - 3	2 - 4

The Fronius Smart Meter has an optional neutral connection that may be used for measuring wye circuits. In the absence of neutral, voltages are measured with respect to ground. The Fronius Smart Meter uses the phase L1 (øA) and phase L2 (øB) connections for power.

Over-Voltage Limit: 125% of nominal Vac. Extended over-voltage operation can damage the Fronius Smart Meter and void the warranty.

Over-Current Limit: 120% of rated current. Exceeding 120% of rated current will not harm the Fronius Smart Meter but the current and power will not be measured accurately.

Maximum Surge: 4 kV according to EN 61000-4-5

Power Consumption:

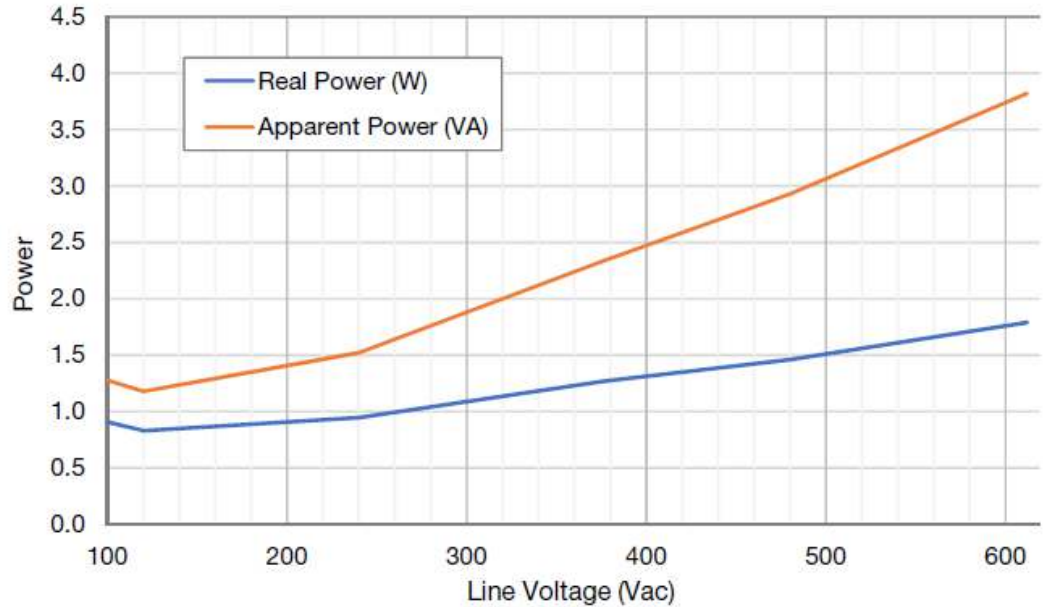

Operating Frequencies: 50 / 60 Hz

Measurement Category: CAT III

Measurement category III is for measurements performed in the building installation. Examples are measurements on distribution boards, circuit breakers, wiring, including cables, bus bars, junction boxes, switches, socket outlets in the fixed installation, and equipment for industrial use and some other equipment, for example, stationary motors with permanent connection to the fixed installation.

The line voltage measurement terminals on the meter are rated for the following CAT III voltages (these ratings appear on the front label):

Meter Service Type	CAT III Voltage Rating
WR	600

Current Transformer Inputs:

Nominal Input Voltage (At CT Rated Current): 0.33333 Vac RMS

Absolute Maximum Input Voltage: 5.0 Vac RMS

Input Impedance at 50/60 Hz: 23 kOhm

Certifications

EMC

- EN55011:2007, CISPR 11:2009- Class B
- FCC Part 15 - Class B
- EN 61326-1:2012, includes:
 - **Harmonics:** IEC 61000-3-2
 - **Flicker:** IEC 61000-3-3
 - **Electrostatic Discharge:** IEC 61000-4-2
 - **Radiated RF Immunity:** IEC 61000-4-3
 - **Electrical Fast Transient / Burst:** IEC 61000-4-4
 - **Surge Immunity:** IEC 61000-4-5
 - **Conducted RF Immunity:** IEC 61000-4-6
 - **Power Frequency H-Field:** IEC 61000-4-8
 - **Voltage Dips, Interrupts:** IEC 61000-4-11

Safety

- UL 61010-1
 - CAN/CSA-C22.2 No. 61010-1-12
 - IEC 61010-2
-

Environmental

Operating Temperature: -40° C to +80° C (-40° F to 176° F)

Altitude: Up to 3000 m (9842 ft)

Operating Humidity: non-condensing, 5 to 90% relative humidity (RH) up to 40°C, decreasing linearly to 50% RH at 55°C

Pollution: POLLUTION DEGREE 2 - Normally only non-conductive pollution; occasionally, a temporary conductivity caused by condensation must be expected.

Indoor Use: Suitable for indoor use

Outdoor Use: Suitable for outdoor use if mounted inside an electrical enclosure (Hammond Mfg., Type EJ Series) rated NEMA 3R or 4 (IP 66).

Fronius manufacturer's warranty

Detailed, country-specific warranty conditions are available at www.fronius.com/solar/warranty.

To obtain the full warranty period for your newly installed Fronius product, please register at www.solarweb.com.



fronius.com/en/solar-energy/installers-partners/products-solutions/monitoring-digital-tools

**MONITORING &
DIGITAL TOOLS**

Fronius International GmbH

Froniusstraße 1
4643 Pettenbach
Austria
contact@fronius.com
www.fronius.com

At www.fronius.com/contact you will find the contact details of all Fronius subsidiaries and Sales & Service Partners.