



Installation Guide

Three Phase Inverters with Synergy Technology

PN:SExxK-xxxxlxxxx

For North America

Version 1.1

Disclaimers

Important Notice

Copyright © SolarEdge Inc. All rights reserved.

No part of this document may be reproduced, stored in a retrieval system or transmitted, in any form or by any means, electronic, mechanical, photographic, magnetic or otherwise, without the prior written permission of SolarEdge Inc.

The material furnished in this document is believed to be accurate and reliable.

However, SolarEdge assumes no responsibility for the use of this material. SolarEdge reserves the right to make changes to the material at any time and without notice. You may refer to the SolarEdge web site (<https://www.solaredge.com/us/>) for the most updated version.

All company and brand products and service names are trademarks or registered trademarks of their respective holders.

Patent marking notice: see <https://www.solaredge.com/us/patent>

The general terms and conditions of delivery of SolarEdge shall apply.

The content of these documents is continually reviewed and amended, where necessary. However, discrepancies cannot be excluded. No guarantee is made for the completeness of these documents.

The images contained in this document are for illustrative purposes only and may vary depending on product models.

FCC Compliance

This equipment has been tested and found to comply with the limits for a Class A digital device, pursuant to part 15 of the FCC Rules.

These limits are designed to provide reasonable protection against harmful interference. This equipment generates, uses and can radiate radio frequency energy and, if not installed and used in accordance with the instructions, may cause harmful interference to radio communications. However, there is no guarantee that interference will not occur in a particular installation. If this equipment does cause harmful interference to radio or television reception, which can be determined by turning the equipment off and on, you are encouraged to try to correct the interference by one or more of the following measures:

- Reorient or relocate the receiving antenna.
- Increase the separation between the equipment and the receiver.
- Connect the equipment into an outlet on a circuit different from that to which the receiver is connected.
- Consult the dealer or an experienced radio/TV technician for help.

Changes or modifications not expressly approved by the party responsible for compliance may void the user's authority to operate the equipment.

Revision History

Version 1.1 (Dec. 2021)

Change in connection method of DC wires to a Synergy Manager with DC wire terminals and updated Rapid Shutdown (PVRSS) initiation. Added mounting brackets dimension drawings.

Version 1.1, August 2021: Initial release

Contents

Disclaimers	1
Important Notice	1
FCC Compliance	2
Revision History	3
HANDLING AND SAFETY INSTRUCTIONS	6
Safety Symbols Information	6
IMPORTANT SAFETY INSTRUCTIONS / CONSIGNES DE SÉCURITÉ IMPORTANTES	7
Photovoltaic Rapid Shutdown System Requirements	11
Photovoltaic Hazard Control Application	13
Chapter 1: Introducing the SolarEdge Power Harvesting System	15
Power Optimizer	15
Three Phase Inverter with Synergy Technology	16
Monitoring Platform	17
Designer	17
Installation Tools and Material List	17
Installation Procedure	18
Chapter 2: Installing the Power Optimizers	19
Safety	19
Package Contents	21
Installation Guidelines	21
Step 1: Mounting and Grounding the Power Optimizers	24
Step 2: Connecting a PV module to a Power Optimizer	27
Step 3: Connecting Power Optimizers in PV strings	28
Step 4: Verifying Proper Power Optimizer Connection	29
Chapter 3: Installing the Synergy Manager and Synergy Units	30
Synergy Manager Package Contents	30
Synergy Unit Package Contents	30
Identifying the Units	30
Front Interface of Synergy Manager	31
Inverter Interconnection Cable Interfaces	35
Synergy Manager External Cable Interface	36
Synergy Unit Interface Connectors	36
Drilling Conduit Holes	37
Mounting and Connecting the Synergy Manager and Synergy Units	38
Chapter 4: Connecting PV Modules and AC to the Synergy Manager	43
Connecting PV Modules to the Synergy Manager	43
Connection Methods	44

Connecting PV Strings to the Synergy Manager	46
Connecting PV Arrays to the Synergy Manager	48
Connecting Ground and AC Wires to the Synergy Manager	50
Chapter 5: Activating, Commissioning and Configuring the System	56
On-grid Commissioning of the inverter	57
Step 1: Activating the Installation	57
Step 2: Commissioning and Configuring the Installation	57
Step 3: Verifying Proper Activation and Commissioning	59
Pre-commissioning (Off-Grid)	60
Reporting and Monitoring Installation Data	61
Signaling Options	63
Appendix A: Errors and Troubleshooting	65
Identifying Errors	65
Power Optimizer Troubleshooting	66
Troubleshooting Communication	68
Appendix B: Adding Optional Components	70
AC Surge Protection Device (SPD)	70
DC Surge Protection Device (SPD)	70
Cellular Plug-in	70
Appendix C: Mechanical Specifications	72

HANDLING AND SAFETY INSTRUCTIONS

Safety Symbols Information

The following safety symbols are used in this document. Familiarize yourself with the symbols and their meaning before installing or operating the system.

WARNING!

Denotes a hazard. It calls attention to a procedure that, if not correctly performed or adhered to, could result in **injury or loss of life**. Do not proceed beyond a warning note until the indicated conditions are fully understood and met.



AVERTISSEMENT!

Dénote un risque: il attire l'attention sur une opération qui, si elle n'est pas faite ou suivie correctement, pourrait causer des blessures ou un danger de mort. Ne pas dépasser une telle note avant que les conditions requises soient totalement comprises et accomplies.

CAUTION!

Denotes a hazard. It calls attention to a procedure that, if not correctly performed or adhered to, could result in **damage or destruction of the product**. Do not proceed beyond a caution sign until the indicated conditions are fully understood and met.



ATTENTION!

Dénote un risque: il attire l'attention sur une opération qui, si elle n'est pas faite ou suivie correctement, pourrait causer un dommage ou destruction de l'équipement. Ne pas dépasser une telle note avant que les conditions requises soient totalement comprises et accomplies.

NOTE



Denotes additional information about the current subject.

IMPORTANT SAFETY FEATURE



Denotes information about safety issues.

IMPORTANT SAFETY INSTRUCTIONS / CONSIGNES DE SÉCURITÉ IMPORTANTES

SAVE THESE INSTRUCTIONS / CONSERVEZ CES INSTRUCTIONS



Warning!

To reduce the risk of injury, read all instructions in this document.

AVERTISSEMENT!

Pour réduire le risque de blessure, lisez toutes les instructions de ce document.

WARNING!



When servicing or replacing SolarEdge equipment, instructions in the SolarEdge Inverter Installation Guide must be followed to maintain the integrity of the PV hazard control system. SolarEdge Power Optimizers and/or inverters may only be replaced with SolarEdge Power Optimizers and/or inverters. Third party equipment is not compatible with SolarEdge equipment.

WARNING!



Using this equipment in a manner not specified by SolarEdge in this document may impair the protection provided by this equipment.

WARNING!



The inverter cover must be opened only after switching the inverter ON/OFF/P switch located at the bottom of the inverter to OFF. This disables the DC voltage inside the inverter. Wait five minutes before opening the cover. Otherwise, there is a risk of electric shock from energy stored in the capacitors.

AVERTISSEMENT!

Ne pas ouvrir le couvercle de l'onduleur avant d'avoir coupé l'interrupteur situé en dessous de l'onduleur. Cela supprime les tensions CC et CA de l'onduleur. Attendre cinq minutes avant d'ouvrir le couvercle. Sinon, il y a un risque de choc électrique provenant de l'énergie stockée dans le condensateur.



P = Program/Pair

1 = ON

0 = OFF

WARNING!



Before operating the inverter, ensure that the inverter is grounded properly. This product must be connected to a grounded, metal, permanent wiring system, or an equipment-grounding conductor must be run with the circuit conductors and connected to the equipment grounding terminal or lead on the product.

AVERTISSEMENT!

Avant d'utiliser l'onduleur monophasé, assurez-vous que l'onduleur est correctement mis à la terre. Ce produit doit être raccordé à un système de

câblage fixe, métallique, l'équipement-le conducteur de mise à la terre doit être exécuté avec les conducteurs de circuit et raccordé à l'équipement borne de mise à la terre ou de plomb sur le produit.

WARNING!



Opening the inverter and repairing or testing under power must be performed only by qualified service personnel familiar with this inverter.

AVERTISSEMENT!

L'unité ne doit être ouverte que par un technicien qualifié dans le cadre de l'installation et de la maintenance.

WARNING!



The Safety Unit meets all requirements for a code-compliant installation of this system. The DC Disconnect Switch disconnects both the positive and negative conductors.

AVERTISSEMENT!

Le sectionneur externe (inclus) répond aux exigences de conformité pour l'installation de ce système. Le coupeur CC ouvre les conducteurs positifs et négatifs.

WARNING!



The inverter input and output circuits are isolated from the enclosure. This system does not include an isolation transformer and should be installed with an ungrounded PV array in accordance with the requirements of NEC Articles 690.35 and 690.43 National Electric Code, ANSI/NFPA 70, 2011 (and Canadian Electrical Code, Part I, for installations in Canada).

Equipment grounding is the responsibility of the installer and must be performed in accordance with all applicable Local and National Codes.

AVERTISSEMENT!

Les circuits d'entrée et de sortie de l'onduleur sont isolés de l'enveloppe. Ce système n'inclut pas d'isolation galvanique (transformateur) et devra être installé sans mise à la terre du champ PV et en accord avec les articles 690.35 et 690.43 du National Electric Code (NEC), ANSI/NFPA 70, 2011 (et du Code Electrique Canadien, Partie 1, pour les installations faites au Canada). La mise à la terre des équipements est la responsabilité de l'installateur et doit être faite en accord avec les toutes les règles locales et nationales applicables.

WARNING!

SafeDC complies with IEC60947-3 when installing the system with a worst case SafeDC voltage (under fault conditions) < 120V.



The worst case voltage is defined as: $V_{oc, max} + (PV \text{ string Length} - 1) * 1V$, where:

- $V_{oc, max}$ = Maximum V_{oc} (at lowest temperature) of the PV modules in the PV string (for a PV string with multiple modules, use the max value)
- PV string Length = number of Power Optimizers in the PV string

WARNING!

SolarEdge products can expose you to chemicals including antimony trioxide, which is known to the State of California to cause cancer. For more information, go to www.P65Warnings.ca.gov.

**AVERTISSEMENT!**

Les produits SolarEdge peut vous exposer à des agents chimiques, y compris trioxyde d'antimoine, identifiés par l'État de Californie comme pouvant causer le cancer. Pour de plus amples informations, prière de consulter www.P65Warnings.ca.gov.

CAUTION!

This unit must be operated according to the technical specification datasheet provided with the unit.

ATTENTION!

Cette unité doit être utilisée selon les spécifications de fonctionnement, comme décrit dans la dernière fiche technique des spécifications.

CAUTION!

HEAVY OBJECT. To avoid muscle strain or back injury, use proper lifting techniques, and if required - a lifting aid.

**ATTENTION!**

Objet lourd. Pour éviter la fatigue musculaire ou des blessures au dos, utilisez des techniques de levage appropriées et, si nécessaire - un auxiliaire de levage lors du retrait.

NOTE

This inverter is provided with an IMI (Isolation Monitor Interrupter) for ground fault protection.

NOTE

The symbol  appears at grounding points on the SolarEdge equipment. This symbol is also used in this manual.

NOTE

SolarEdge inverters can be installed in sites with an alternative power source such as a generator. SolarEdge requires installing a physical or electronic interlock, which will signal to the inverter when the grid has been disconnected. Interlock procurement, installation, maintenance and support are the responsibility of the installer. Damage to the inverter due to incorrect interlock installation or use of an interlock that is incompatible with the SolarEdge system will render the SolarEdge warranty invalid.



For more information on connecting an alternative power source to SolarEdge inverter, refer to

<https://www.solaredge.com/sites/default/files/se-inverter-support-of-voltage-sources.pdf>.



Photovoltaic Rapid Shutdown System Requirements

This section is applicable to all Three Phase Inverters with Synergy Technology having Synergy Units marked with "R" in the part numbers: SESUK-USRxxxxx.

WARNING!



THIS PHOTOVOLTAIC RAPID SHUTDOWN SYSTEM (PVRSS) INCORPORATES ONE OR MORE PIECES OF EQUIPMENT THAT EXERCISE THE RAPID SHUTDOWN CONTROL OF PV SYSTEM CONDUCTORS REQUIRED BY SECTION 690.12 OF THE NEC (NFPA 70). OTHER EQUIPMENT INSTALLED IN OR ON THIS PV SYSTEM MAY ADVERSELY AFFECT THE OPERATION OF THIS PVRSS. IT IS THE RESPONSIBILITY OF THE INSTALLER TO ENSURE THAT THE COMPLETED PV SYSTEM MEETS THE APPLICABLE RAPID SHUT DOWN FUNCTIONAL REQUIREMENTS. THIS EQUIPMENT MUST BE INSTALLED ACCORDING TO THE MANUFACTURER'S INSTALLATION INSTRUCTIONS.

- SolarEdge inverters and power optimizers installed together form a photovoltaic rapid shutdown system (PVRSS). All inputs and outputs of the inverter and power optimizers comply with photovoltaic rapid shutdown requirements for controlled conductors both inside and outside the PV array boundary. To form a PV rapid shutdown system, no more than 30 power optimizers should be installed in series. Each power optimizer will output around 1 Vdc when rapid shutdown is initiated. Rapid shutdown time limit is 30 Sec.
- This SolarEdge system is compatible with the **Grid support interactive compatible** functionality.
- All DC and AC conductors served by the power optimizers and inverters are controlled by the photovoltaic rapid shutdown system. The AC branch circuit conductors serving the inverter may remain energized until the AC service panel is de-energized. Installers must provide signage complying with Section 690.56(C) of the NEC (NFPA 70).
- Buildings with rapid shutdown PV systems, complying with NEC 690.56(C), shall have permanent labels as described in 690.56(C)(1) through (C)(2):
 - (1)(a) For PV systems that shut down the array and conductors leaving the array: The title "**SOLAR PV SYSTEM EQUIPPED WITH RAPID SHUTDOWN**" shall utilize capitalized characters with a minimum height of 3/8 in. in black on yellow background, and the remaining characters shall be capitalized with a minimum height of 3/16 in. in black on white background.

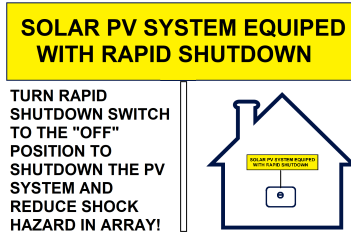

- (2) A rapid shutdown switch shall have a label located on or no more than 3 ft from the switch that includes this wording. The label shall be reflective, with all letters capitalized and having a minimum height of 3/8 in., in white on red background.

PV SYSTEM PV WITH RAPID SHUTDOWN

Photovoltaic Hazard Control Application

SolarEdge commercial optimizers and inverters have been evaluated and listed to UL 3741 and may be used to form a PV hazard control system that utilizes SolarEdges PV rapid shutdown system to comply with NEC 690.12. Multiple modules may be connected in series to the optimizer input without exceeding the input voltage rating of the optimizer (125V dc). The diagram below depicts a typical PV hazard control system using multiple PV modules in series connected to optimizers. Installation instructions, warnings and cautions in this installation guide must be followed to comply with Local codes . The PVRSS shall be installed by qualified persons in accordance with the installation instructions and all applicable installation codes and standards.

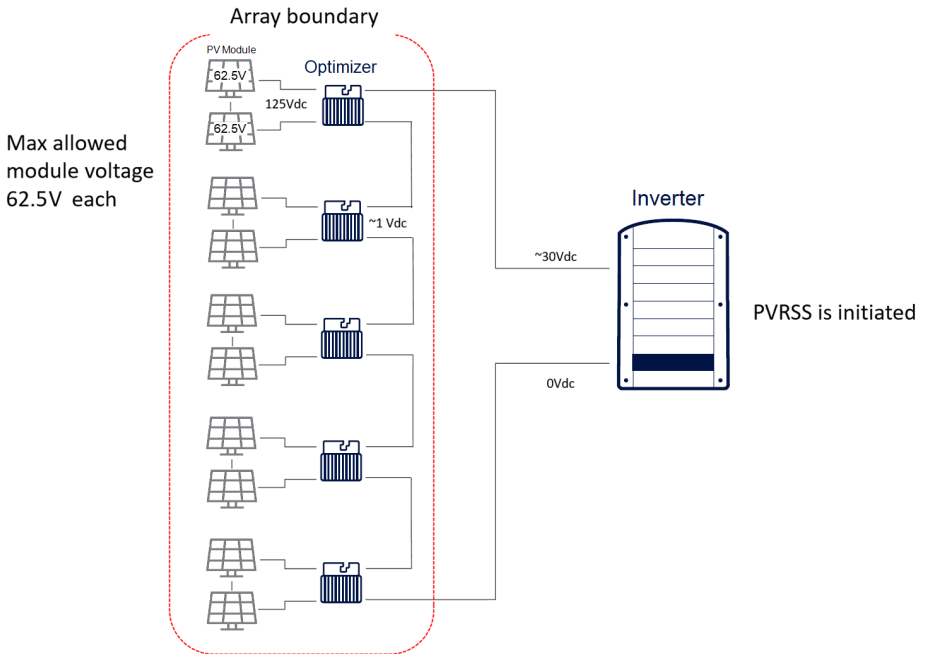

Power optimizer models with input Voltage up to 125Vdc, when used with SolarEdge three phase inverters and DC safety switches listed and marked with PVRSS, may be used to form a Listed Photovoltaic Hazard Control System.

NOTE



Power optimizer models compliant with SolarEdge PV Hazard Control System: UL3741 listed models as noted on power optimizer datasheet.

WARNING!

Upon servicing replacing equipment, instructions in this installation guide must be followed to maintain the integrity of the PV hazard control system. SolarEdge commercial optimizers and three phase inverters should only be replaced with SolarEdge commercial optimizers and inverters. Third party equipment is not compatible.

Chapter 1: Introducing the SolarEdge Power Harvesting System

The SolarEdge power harvesting solution is designed to maximize the power output from any type of solar Photovoltaic (PV) installation while reducing the average cost per Watt. *Figure 1* shows and the following sections describe the components of the SolarEdge power harvesting system.

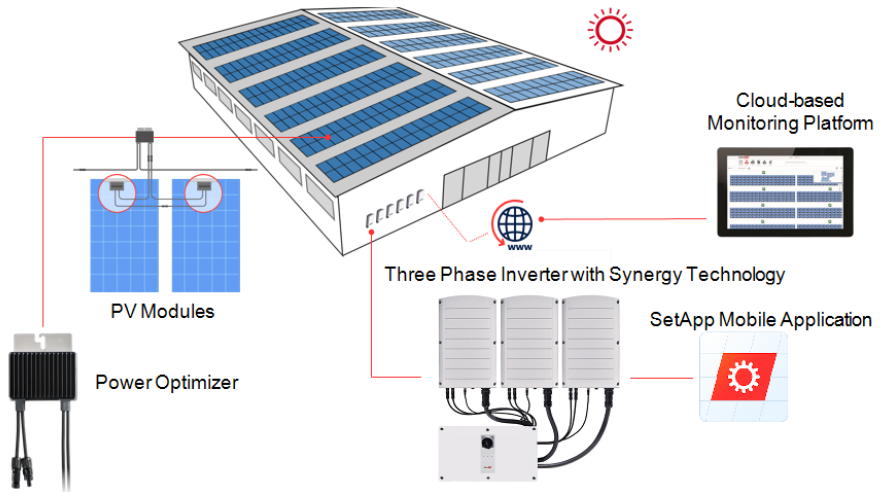

Figure 1: The SolarEdge power harvesting system components

Power Optimizer

The Power Optimizers are DC-DC converters connected to PV modules to maximize power harvesting by performing independent Maximum Power Point Tracking (MPPT) at the module level.

The Power Optimizers regulate the PV string Voltage at a constant level, regardless of PV string length and environmental conditions.

Each Power Optimizer transmits the power production status of the PV module and other performance data over the DC power line to the inverter.

The Power Optimizers include a safety Voltage mechanism that automatically reduces the output of each Power Optimizer to 1 Vdc in the following cases:

- During fault conditions
- The Power Optimizers are disconnected from the inverter
- The inverter ON/OFF/P switch is turned OFF

The safety Voltage mechanism of the Power Optimizers also serves as part of a Photovoltaic Rapid Shutdown System (PVRSS).

PVRSS, enable firefighters to reduce the Voltage and current of a PV strings to protect themselves from electrical hazards during fire.

Rapid Shutdown is initiated by one of the following methods:

- The Inverter AC breaker is turned OFF, or AC to the inverter is disconnected intentionally or as result of a fault or by another method (Applicable for Three Phase Inverters with Synergy Technology having Synergy Unit PN:SESUK-USRxxxxxx).
- The DC Disconnect Switch on the front panel Synergy Manager is turned OFF.

Two types of Power Optimizers are available:

- Module add-on Power Optimizer – connected to one or more modules
- Smart modules - the Power Optimizer is embedded into a module

Three Phase Inverter with Synergy Technology

The Three Phase Inverter with Synergy Technology (referred to as 'inverter' in this manual) efficiently converts DC power from the PV modules into AC power that can be fed into the main AC service of the site and from there to the grid. The inverter also receives the monitoring data from each Power Optimizer and transmits it to the SolarEdge Monitoring platform (requires a land-line or cellular connection to the Internet).

The inverter is comprised of two or three Synergy unit inverters (depending on the model) accompanied an external Synergy Manager unit. The Inverter may include two or three Synergy Units, depending on the inverter's model.

The Synergy Units are connected to the Synergy Manager via AC, DC and communication cables.

Each Synergy Unit operates independently and continues to work in case others stopped operating.

A chain of up to 31 inverters can be set to operate together via Modbus on RS485 line. When setting a chain of inverters, the inverter that manages communication interface to the internet is called Leader and the rest are Followers.

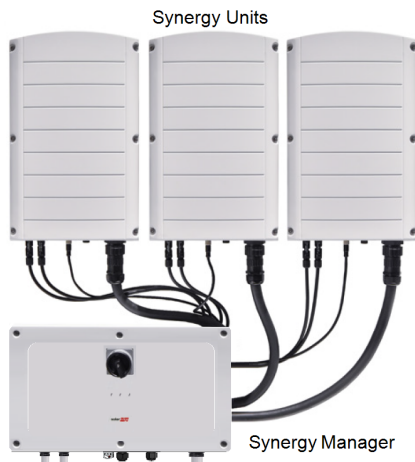

Figure 2: Synergy Manager with three Synergy Units

Monitoring Platform

The monitoring platform enables monitoring the technical and financial performance of one or more SolarEdge sites. It provides past and online information on the system performance, both at the system and PV module levels.

Designer

Designer recommends inverter and Power Optimizer selection per site size and enables report generation. You can create a project in Designer and export the site design with the PV array layout to the monitoring platform.

Installation Tools and Material List

Standard tools can be used during the installation of the SolarEdge system.

The following recommend tools is required for installation:

- Allen screwdriver for 5mm screw type for the inverter cover, Synergy Manager cover, and inverter side screws
- Standard flat-head screwdrivers set
- Non-contact Voltage detector
- Cordless drill (with a torque clutch) or screwdriver and bits suitable for the surface on which the inverter and Power Optimizers are installed and for opening the Safety Unit drill guides. Use of an impact driver is *not* allowed

- Ring terminals crimping tool
- Wire cutters
- Wire strippers
- Voltmeter

For installing the communication options, you may also need the following:

- For Ethernet:
 - CAT6 twisted pair Ethernet cable with RJ45 connector
 - If using a CAT6 cable spool: RJ45 plug and RJ45 crimper
- For RS485 / CAN Bus :
 - Four- or six-wire shielded twisted pair cable
 - Watchmaker precision screwdriver set

Installation Procedure

The following procedures, are required for installing and setting up a new SolarEdge site. Some of these procedures also apply to modification of an existing site.

1. [Installing the Power Optimizers](#)
2. [Installing the Synergy Manager and Synergy Units](#)
3. "Connecting PV Modules and AC to the Synergy Manager" on page 43
4. [Connecting AC and PV Strings to the Synergy Manager](#)
5. [Activating, Commissioning and Configuring the System](#)
6. [Setting Up Communication with the Monitoring Platform](#)

Chapter 2: Installing the Power Optimizers

Safety

The following notes and warnings apply when installing the SolarEdge Power Optimizers. Some of the following may not be applicable to smart modules:

WARNING!



The metallic enclosure of the Power Optimizer must be grounded in accordance with the product's listing and local and national codes.

AVERTISSEMENT!

L'enceinte métallique de l'optimiseur de puissance doit être mise à la terre en accord avec les réglementations locales et nationales.

WARNING!



When modifying an existing installation, turn OFF the inverter ON/OFF/P switch, the DC Disconnect Switch and the AC circuit breaker on the main AC distribution panel.

AVERTISSEMENT!

Avant de faire ces étapes, éteignez l'onduleur monophasé en mettant sur OFF l'interrupteur ON/OFF situé au bas de l'onduleur.

CAUTION!



Power Optimizers are IP68/NEMA6P rated. Choose a mounting location where optimizers will not be submerged in water.

ATTENTION!

Les optimiseurs de puissances sont compatibles à la norme IP68/NEMA6P. Choisissez le lieu de montage tel que l'optimiseur ne puisse pas être submergé par l'eau.

CAUTION!



This unit must be operated according to the operating specifications provided with the unit.

ATTENTION!

Cette unité doit être opérée suivant les instructions trouvées dans le manuel fourni avec le produit.

CAUTION!



Cutting the Power Optimizer input or output cable connector is prohibited and will void the warranty.

ATTENTION!

Sectionner les câbles d'entrées ou de sortie de l'optimiseur est interdit et annule sa garantie.

**CAUTION!**

All PV modules must be connected to a Power Optimizer.

ATTENTION!

Tous les modules doivent être connectés à un optimiseur de puissance.

CAUTION!

If you intend to mount the Power Optimizers directly to the module or module frame, first consult the module manufacturer for guidance regarding the mounting location and the impact, if any, on module warranty. Drilling holes in the module frame should be done according to the module manufacturer instructions.

ATTENTION!

Pour installation à même le module ou la monture du module, consultez d'abord le fabricant du module sur la position et son impact sur la garantie du module. Le perçage de trous dans le cadre du module devra se faire suivant les instructions du fabricant.

IMPORTANT SAFETY FEATURE

Modules with SolarEdge Power Optimizers are safe. They carry only a low safety voltage before the inverter is turned ON. As long as the Power Optimizers are not connected to the inverter or the inverter is turned OFF, each Power Optimizer will output a safe voltage of 1V.

**CAUTION!**

Installing a SolarEdge system without ensuring compatibility of the module connectors with the Power Optimizer connectors may be unsafe and could cause functionality problems such as ground faults, resulting in inverter shut down. To ensure mechanical compatibility of the SolarEdge Power Optimizers' connectors with the PV modules' connectors to which they are connected:

- Use identical connectors from the same manufacturer and of the same type on both the Power Optimizers and on the modules; or
- Verify that the connectors are compatible in the following way:
- The module connector manufacturer should explicitly verify compatibility with the SolarEdge Power Optimizer connector; and the Inverter DC input connectors.
- A third-party test report by one of the listed external labs (TUV, VDE, Bureau Veritas UL, CSA, InterTek) should be obtained, verifying the compatibility of the connectors.

ATTENTION!

Les connecteurs du module doivent être mécaniquement compatibles avec les optimiseurs de puissance. Sinon, le système SolarEdge installé peut être dangereux ou causer des problèmes fonctionnels, tels que les défauts de terre, qui peuvent provoquer un arrêt de l'onduleur. Afin d'assurer la compatibilité mécanique entre les optimiseurs de puissance SolarEdge et les modules auxquels ils sont connectés:

- Utiliser des connecteurs identiques du même fabricant et du même type aussi bien pour les optimiseurs de puissance que pour les modules.*
- Vérifiez que les connecteurs sont compatibles de la manière suivante:*
- Le fabricant du connecteur doit explicitement vérifier la compatibilité avec le connecteur SolarEdge.*
- Un rapport de test de tierce partie doit être effectué par l'un des laboratoires externes indiqués ci-dessous:(TUV, VDE, Bureau Veritas UL, CSA, Intertek), qui vérifiera la compatibilité des connecteurs.*

Package Contents

- Power Optimizers
- Stainless steel grounding lock washers

Installation Guidelines

- For the minimum and maximum number of Power Optimizers in a PV string (PV string length), see the Power Optimizer datasheets. Refer to the Designer for PV string length verification. The Designer is available on the SolarEdge website at: <https://www.solaredge.com/us/products/installer-tools/designer#/>.
- *Do not* use extension cables between a module and a Power Optimizer, between two modules connected to the same Power Optimizer, or between two Power Optimizers other than in the following cases:

Between a Power Optimizer and a module:

- Extension cables of up to 6 ft / 1.8 m are allowed for all Power Optimizers (3 ft / 0.9 m for DC+, and 3 ft / 0.9 m for DC -).
- S-Series Power Optimizers with the 1-type suffix in their part number (Sxxx-1xxxxxx) - extension cables of up to 52 ft / 16 m can be installed per Power Optimizer (26 ft / 8 m for DC+, and 26 ft / 8 m for DC-).

- P-Series Power Optimizers with the 4-type suffix in their part number (Pxxx-4xxxxxx) and the Mxxx-Series - extension cables of up to 52 ft / 16 m can be installed per Power Optimizer (26 ft / 8 m for DC+, and 26 ft / 8 m for DC-).

Between two Power Optimizers or between a Power Optimizer and the inverter:

- Extension cables can be installed between Power Optimizers only from row to row, around obstacles or pathways within a row and from the end of the PV string to the inverter. The total length of the extension cables may not exceed the following values:

Single Phase Inverters	Three Phase Inverters
All - 1000 ft / 300 m	SE17K and below - 300 m
	SE17.5K and above - 700 m
	SE9KUS, SE20KUS - 300 m / 1000 ft
	SE14.4KUS, SE17.3KUS, SE33.3KUS, SE40KUS - 700 m / 2300 ft

- The same rules apply for Synergy units of equivalent power ratings, that are part of the modular Synergy technology inverter.
- For connecting homerun DC cables from Power Optimizers to the inverter, use cables with the following cross-sections:
 - For MC4 connectors: 8-14 AWG/2.5-10 mm²
 - For DC terminal blocks inside the inverter or Safety Unit (if applicable): 6-14 AWG/2.5-16 mm²
- Frame-mounted Power Optimizers are mounted directly on the module frame, regardless of racking system (rail-less or with rails). For installation of frame-mounted Power Optimizers, refer to http://www.solaredge.com/sites/default/files/installing_frame_mounted_power_optimizers.pdf.
- The Power Optimizer can be placed in any orientation.
- If connecting more modules than Power Optimizer inputs in parallel, use a branch cable. Some commercial Power Optimizer models have a dual input.
- Position the Power Optimizer close enough to its module so that their cables can be connected.
- Make sure to use Power Optimizers that have the required output and input conductor length.

- Completely shaded modules may cause their Power Optimizers to temporarily shut down. This will not affect the performance of the other Power Optimizers in the PV string, as long as the minimum number of unshaded Power Optimizers connected in a PV string of modules is met. If under typical conditions fewer than the minimum Power Optimizers are connected to unshaded modules, add more Power Optimizers to the PV string.

- To allow for heat dissipation, maintain the following clearance:

All Power Optimizers, except for the P860 and P960 Power Optimizers

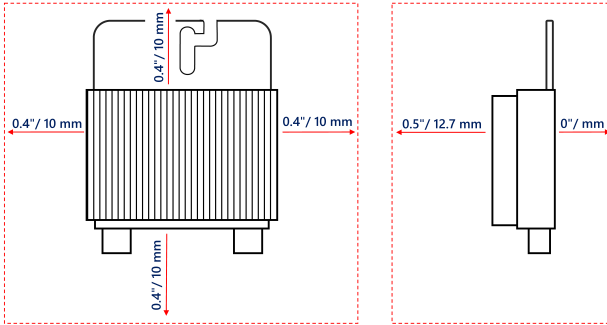

P860, P960 and M1600 Power Optimizers

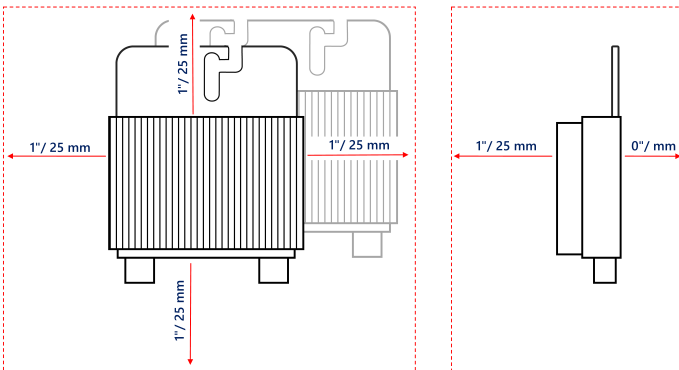

- Equipment grounding tightening torques: 4-6 AWG: 45 lb-in, 8 AWG: 40 lb-in, 10-14 AWG: 35 lb-in.
- When installing PV modules in a confined space such as Building-integrated photovoltaic (BIPV) modules, ventilation measures may be required to ensure that the Power Optimizers are not exceeding the maximum temperatures stated in their specifications.

Step 1: Mounting and Grounding the Power Optimizers

For each of the Power Optimizers⁽¹⁾:

1. Determine the Power Optimizer mounting location and use the Power Optimizer mounting brackets to attach the Power Optimizer to the support structure (See *Figure 3*). It is recommended to mount the Power Optimizer in a location protected from direct sunlight. For frame-mounted Power Optimizers follow the instructions supplied with the optimizers, or refer to https://www.solaredge.com/sites/default/files/installing_frame_mounted_power_optimizers.pdf.
2. If required, mark the mounting hole locations and drill holes.



CAUTION!



Drilling vibrations may damage the Power Optimizer and will void the warranty. Use a torque wrench or an electric drill with adjustable clutch that meets the mounting torque requirements. *Do not* use impact drivers for mounting the Power Optimizer.

Do not drill through the Power Optimizer or through the mounting holes.

ATTENTION!

Les vibrations résultant du perçage peuvent endommager l'optimiseur de puissance et annulera la garantie. Utilisez une clé dynamométrique ou une perceuse électrique avec embrayage adaptable compatible avec les moments indiqués. Ne pas utiliser des tournevis à percussion pour fixer l'optimiseur. Ne pas percer à travers l'optimiseur de puissance ou ses trous de fixation.

3. Attach each Power Optimizer to the rack using M6 (1/4") or M8 stainless steel bolts, nuts and washers or other mounting hardware. Apply torque of 6.5-7 lb*ft/9-10 N*m.

For 3NA series power optimizers, SolarEdge recommends mounting the Power Optimizer on a rail with the smooth side facing out, so that the Power Optimizer body will prevent its rotation.

⁽¹⁾Not applicable to smart modules.

4. Use the following methods⁽¹⁾ to ground the Power Optimizer:

WARNING!



The metallic enclosure of the Power Optimizer must be grounded in accordance with the requirements of the local and national codes.

AVERTISSEMENT!

L'enceinte métallique de l'optimiseur de puissance doit être mise à la terre en accord avec les réglementations locales et nationales.

- **For mounting on a grounded metal rail:** Use the provided 5/16" stainless steel grounding star washer between the railing and the flat side of the mounting bracket. The grounding washer should break through the anodize coating of the railing to ensure low resistive connection. Apply a torque of 9.5 N*m / 7 lb*ft.

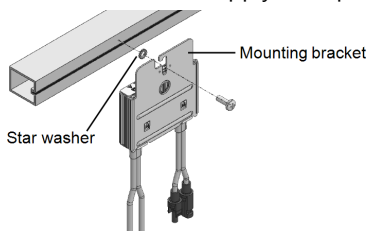

Figure 3: Power Optimizer installation and grounding using a star washer

⁽¹⁾These methods have been evaluated by a nationally recognized testing laboratory as part of the Power Optimizer evaluation. The SolarEdge-supplied grounding lug kit has been evaluated only for use with SolarEdge power optimizers. It is not intended or listed to be used as a general purpose grounding lug with other electrical equipment.

- For mounting on rails with sliding nut fasteners:** If the star washer cannot be used, use the SolarEdge grounding plate (purchased separately) between the railing and the flat side of the mounting bracket. Use mounting specific hardware as needed. Apply a torque of 9.5 N*m / 7 lb*ft. See *Figure 4*.

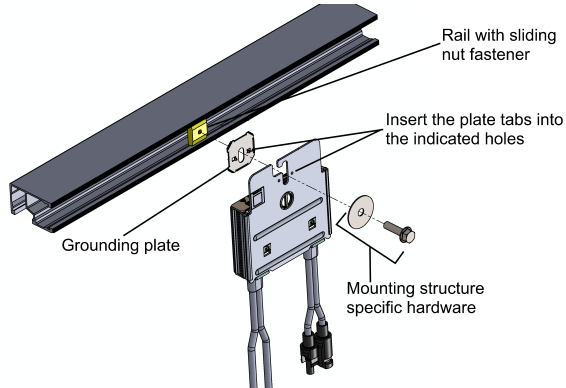

Figure 4: Power Optimizer installation and grounding using a grounding plate

- For mounting on un-grounded structures (such as a wooden structure):** If the star washer or the plate cannot be used, use the SolarEdge grounding lug (purchased separately) with an equipment-grounding conductor according to the supplied instructions. The grounding terminal accepts a wire size of 6-14 AWG, and must be sized for equipment grounding per NEC 250.122 requirements. Tighten the screws connecting the Power Optimizer to the frame and the grounding terminal screw. Apply a torque of 9.5 N*m / 7 lb*ft.

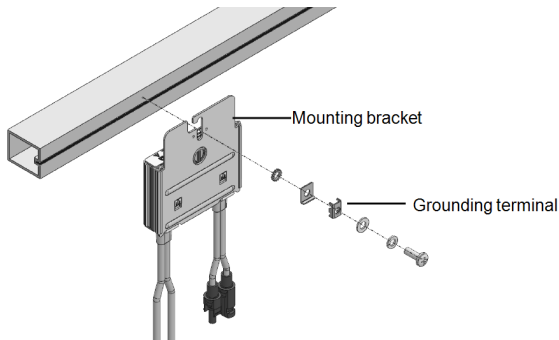

Figure 5: Power optimizer grounding terminal

5. Verify that each Power Optimizer is securely attached to the module support structure.
6. Record Power Optimizer serial numbers and locations, as described in *Reporting and Monitoring Installation Data* on page 61.

Step 2: Connecting a PV module to a Power Optimizer

NOTE



Improper wiring may cause electrical faults in a PV system. To avoid electrical faults, verify proper locking of connectors and avoid cable tension and friction. Proper planning, materials and installation reduce the risk of electric arcs, short-circuits and ground faults in the PV system.

NOTE



Images are for illustration purposes only. Refer to the label on the product to identify the plus and minus input and output connectors.

For each of the Power Optimizers:

- Connect the Plus (+) output connector of the module to the Plus (+) input connector of the Power Optimizer.
- Connect the Minus (-) output connector of the module to the Minus (-) input connector of the Power Optimizer.

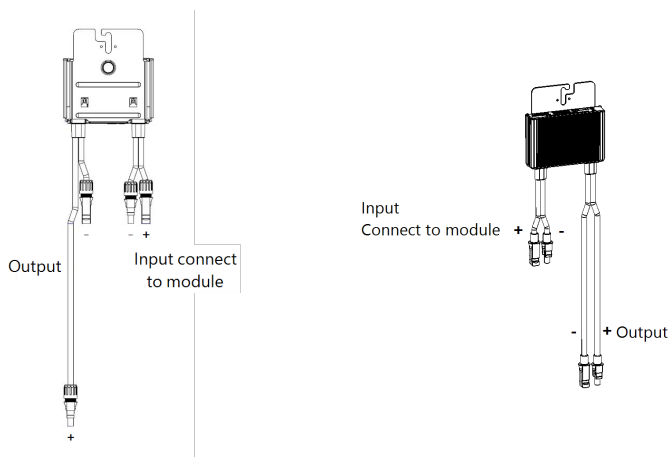

Figure 6: S-Series (left) and P-Series (right) Power Optimizer connectors

Step 3: Connecting Power Optimizers in PV strings

You can construct parallel PV strings of unequal length, that is, the number of Power Optimizers in each PV string does not have to be the same. The minimum and maximum PV string lengths are specified in the power datasheets. Refer to the SolarEdge Site Designer for PV string length verification.

IMPORTANT SAFETY FEATURE



- For a compliant PV Rapid Shutdown (PVRSS) installation, use no more than 30 Power Optimizers per PV string.
- Enabling PVRSS from the inverter menu is only required if the installed Power Optimizers were manufactured before 2015, otherwise it is enabled by default.

NOTE



The DC bus of each unit is separate and not shared for all units. Therefore, in addition to following the inverter design rules, each unit should follow the unit design rules as detailed in the Technical Specifications.

1. Connect the Minus (-) output connector of the PV string's first Power Optimizer to the Plus (+) output connector of the PV string's second Power Optimizer.
2. To minimize electromagnetic interference (EMI), make sure to minimize the distance between the positive and negative DC cables.

For detailed instructions, see:

<https://www.solaredge.com/sites/default/files/se-emi-performance-application-note.pdf>



3. Connect the rest of the Power Optimizers in the PV string in the same manner.

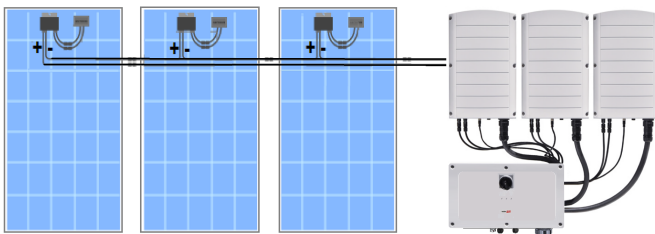

Figure 7: Power Optimizers connected in series

4. If you intend to monitor the installation, using the SolarEdge Monitoring platform, record the physical location of each Power Optimizer, as described in *Creating Logical and Physical Layout using Installation Information* on page 62.

Step 4: Verifying Proper Power Optimizer Connection

When a module is connected to a Power Optimizer, the Power Optimizer outputs a safe voltage of 1V ($\pm 0.1V$). Therefore, the total PV string voltage should equal 1V times the number of Power Optimizers connected in series in the PV string. For example, if 10 Power Optimizers are connected in a PV string, then 10V should be produced.

Make sure the PV modules are exposed to sunlight during this process. The Power Optimizer will only turn ON if the PV module provides at least 2W.

In SolarEdge systems, due to the introduction of Power Optimizers between the PV modules and the inverter, the short circuit current I_{SC} and the open circuit voltage V_{OC} hold different meanings from those in traditional systems.

For more information about the SolarEdge system's PV string Voltage and current, refer to the *V_{OC} and I_{SC} in SolarEdge Systems Technical Note*, available on the SolarEdge website at:

https://www.solaredge.com/sites/default/files/isc_and_voc_in_solaredge_systems_technical_note.pdf



→ To verify proper Power Optimizer connection:

- Measure the voltage of each PV string individually before connecting it to the other PV strings or to the inverter. Verify correct polarity by measuring the PV string polarity with a voltmeter. Use a voltmeter with at least 0.1V measurement accuracy.

NOTE



Since the inverter is not yet operating, you may measure the PV string Voltage and verify correct polarity on the DC wires inside the Synergy ManagerConnection Unit.

For troubleshooting Power Optimizer operation problems, refer to *Power Optimizer Troubleshooting* on page 66.

Proper Power Optimizer connection can also be verified in the Designer application.

For more information, refer to

<https://www.solaredge.com/products/installer-tools/designer#/>.



Chapter 3: Installing the Synergy Manager and Synergy Units

This section, describes how to install the inverter. Install the Synergy Manager and Synergy Unit either before or after the PV modules and Power Optimizers have been installed.

The inverter is provided with a mounting template that ensures correct installation location of the Synergy Manager and all Synergy Unit mounting brackets. The template ensures that all the Synergy Unit inter-connecting cables can reach the Synergy Units and correct distance between the units ensures proper heat dissipation.

First, mount the Synergy Units and then the Synergy Manager. The Synergy Units can be installed in any order.

Synergy Manager Package Contents

- Synergy Manager
- Synergy Units
- Installation template
- Mounting bracket kit
- Two Allen screws for fastening the unit to the mounting bracket
- Cable lock(s)
- Quick Installation guide

Synergy Unit Package Contents

- Synergy Unit
- Mounting bracket kit
- Two Allen screws for fastening the unit to the mounting bracket

Identifying the Units

Stickers on the Synergy Manager and Synergy Units show Serial Numbers.

When creating a site in the SolarEdge Monitoring platform or contacting SolarEdge support, provide the inverter's serial number.

Front Interface of Synergy Manager

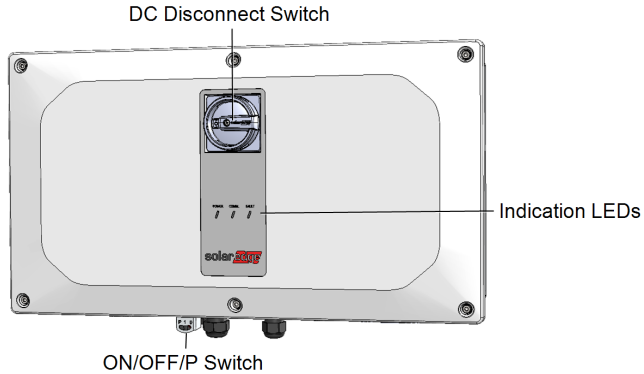

Figure 8: Synergy Manager Unit - Front interfaces

DC Disconnect Switch

The DC Disconnect Switch is a manually operated safety switch for disconnecting the DC power of the SolarEdge system.

NOTE

When the Synergy Manager is OFF (for example during maintenance) it may be locked to prevent a safety hazard:



1. Move the switch to the Lock position.
2. Insert the lock through the knob opening and lock.



ON/OFF/P Switch

Figure 9 shows the ON/OFF/P switch of the Synergy Manager.

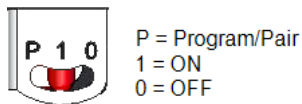

Figure 9: ON/OFF/P switch

- **ON (1)** - Turning this switch ON (after Power Optimizer pairing) starts the operation of the Power Optimizers, enables power production and allows the inverter to begin exporting power to the utility grid.

- **OFF (0)** - Turning this switch OFF reduces the Power Optimizer Voltage to a low safety Voltage and inhibits exportation of power. When this switch is OFF, the Synergy Manager and Synergy Units control circuitry remains powered up.
- **P** - Holding the switch pressed in P position allows performing the following functions:

P Position duration	Function	Comments
Switch moved to P for less than 5 seconds , then released.	<ul style="list-style-type: none"> • Displays production information for 5 seconds on the SetApp screen. • Displays error type indications (if exist) for 5 seconds. • Activates the Wi-Fi access point for connecting to the SolarEdge Inverter SetApp 	While the switch is in P, all LEDs are ON
Switch moved to P for more than 5 seconds , then released.	Starts pairing	

WARNING!



For inverters with manual Rapid Shutdown (PVRSS) functionality - Upon PVRSS, the internal circuitry remains up, therefore the inverter cover must be opened only after shutting off the inverter ON/OFF switch. This disables the DC Voltage inside the inverter (Synergy Manager). Wait five minutes before opening the cover. Otherwise, there is a risk of electric shock from energy stored in the capacitors.

AVERTISSEMENT!

A la Coupure Rapide (PVRSS) les circuits internes restent actifs, il est donc impératif de n'ouvrir le couvercle qu'après avoir arrêté l'onduleur à l'aide de l'interrupteur ON/OFF. Ceci coupe la tension DC à l'intérieur de l'onduleur. Attendez cinq minutes avant d'ouvrir le couvercle. Sinon, il y a risque d'électrocution due à l'énergie stockée dans les condensateurs.

Indication LEDs

LEDs indication consists on color and state (on/ off/ blinking⁽¹⁾/ flickering⁽²⁾/alternating⁽³⁾). The LEDs indicate different system information, such as errors or performance.

Figure 10 shows the Indication LEDs of the Synergy Manager.

Generally, the main LED indications are:

- COMM. ON - the inverter is communicating with the monitoring platform
- POWER ON - the system is producing
- POWER blinking - AC is connected but the system is not producing power
- FAULT ON - system error

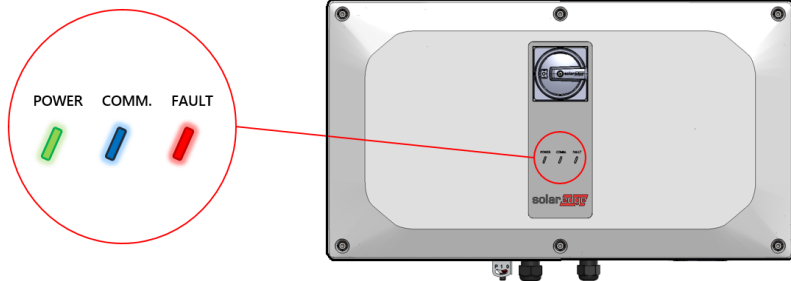

Figure 10: Indication LEDs

(1)Blinking = Turns ON and OFF for the same duration

(2)Flickering = Turns ON for 100 mS and turns OFF for 5 seconds

(3)Alternating = Alternate LEDs flash

Indication	ON/ OFF/ P switch position	LED			Comment
		FAULT	POWER	COMM.	
Power Optimizers not paired	ON (1)	OFF	Blinking	<ul style="list-style-type: none"> • S_OK: ON • No S_OK: OFF 	S_OK: ON communication with the monitoring platform is established
Pairing		Blinking	Blinking	Blinking	
Wake-up/ Grid Monitoring		OFF	Blinking	Blinking	
System Producing		OFF	ON	<ul style="list-style-type: none"> • S_OK: ON • No S_OK: OFF 	
Night mode (no production)		OFF	Flickering	<ul style="list-style-type: none"> • S_OK: ON • No S_OK: OFF 	
Inverter is OFF (Safe DC)		OFF (0)	OFF	Blinking	<ul style="list-style-type: none"> • S_OK: ON • No S_OK: OFF
Inverter is OFF (DC not safe)	OFF (0)	Blinking	Blinking	<ul style="list-style-type: none"> • S_OK: ON • No S_OK: OFF 	
Inverter configuration or reboot	ON / P	ON	ON	ON	
Inverter firmware upgrade	ON / P	Alternating	Alternating	Alternating	The upgrade process can take up to 20 minutes
Error	Any	ON	ON/ OFF/ Blinking/ Flickering	ON/ OFF / Blinking/ Flickering	Refer to <i>Errors and Troubleshooting</i> on page 65

The following table describes production percentage of AC information by LED color and ON/OFF/P switch position.

Indication	ON/ OFF/ P switch position	LED color			Comment
		Red	Green	Blue	
Percentage of AC Production: 0 - 33 %	ON (1)	OFF	ON	OFF	This indicates power production as percentage of rated peak AC output power
Percentage of AC Production: 33 - 66 %		OFF	OFF	ON	
Percentage of AC Production: 66 - 100 %		OFF	ON	ON	

Inverter Interconnection Cable Interfaces

The cables on the right hand side of the Synergy Manager, interfaces the Synergy Manager to the Synergy Unit of the inverter.

NOTE



Models of the Three Phase Inverters with Synergy Technology are provided with either two or three Synergy Units. The following connection description refers to inverter models with three Synergy Units. In inverter models with two Synergy Units, the Manager Unit connects to the left and center Synergy Units.

To connect cables, follow the writing shown next to each cable on the panel.

Figure 11 shows the interconnecting cables of the inverter.

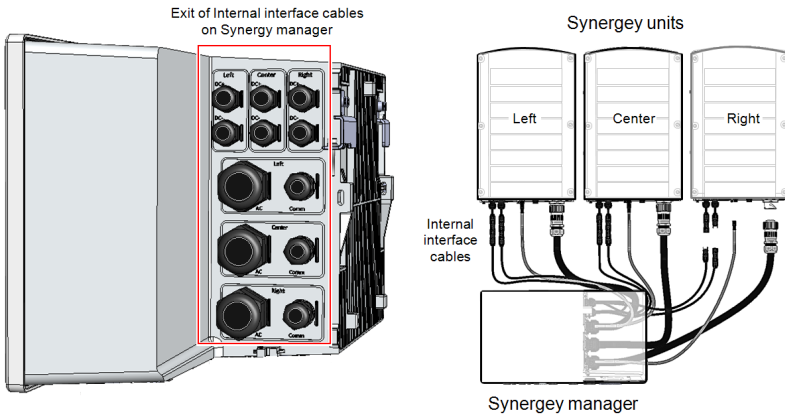

Figure 11: Inverter - interconnection cables

Synergy Manager External Cable Interface

The conduit entries, at the bottom side of the Synergy Manager, interfaces the inverter to the grid and PV arrays. The communication glands, support communication cables connecting the inverter to the SolarEdge Monitoring platform and external power bank used for setting up the inverter in sites with no available grid power.

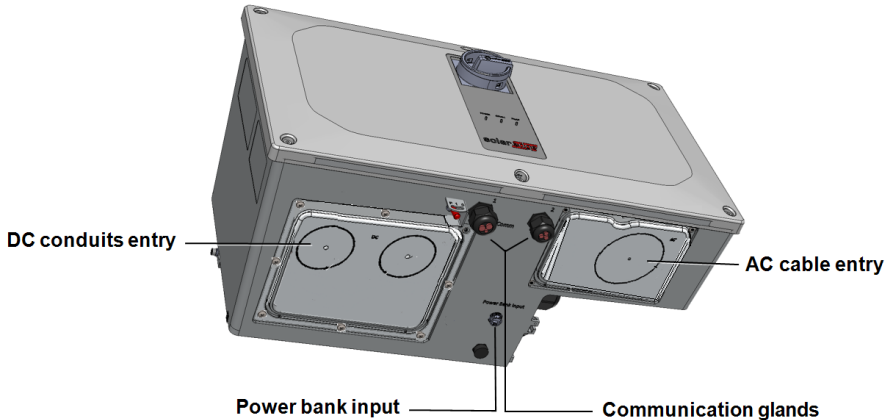

Figure 12: Synergy Manager - bottom view

- **AC Conduits Entry:** drill guides for conduits running AC cable from the grid
- **DC Conduits Entries:** drill guides for conduits running DC cables from the PV arrays
- **Power Bank Input:** power bank connection enables inverter pre-commissioning when AC power is not connected
- **Communication Glands:** two communication glands for connecting communication and antenna cables.

Synergy Unit Interface Connectors

The Synergy Unit connectors are used to interface the Synergy Unit to the Synergy Manager:



NOTE

Connect cables according to labels shown on the Synergy Manager.

- **DC connectors** for DC input from the Synergy Manager
- **Communication connector:** for communication with the Synergy Manager

- **AC connector:** for supply of AC power to the Synergy Manager

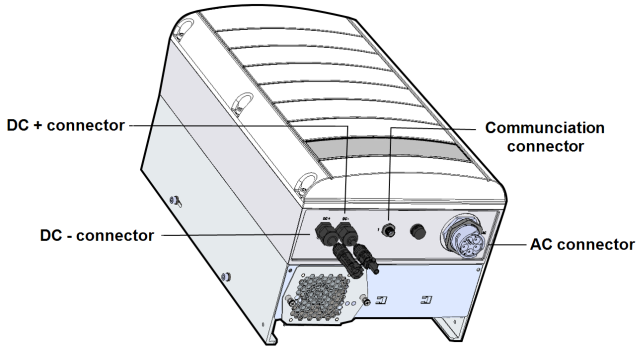

Figure 13: Synergy Unit Interface Connectors

Drilling Conduit Holes

This section describes how to drill AC and DC openings at the bottom of the Synergy Manager for connecting the AC and DC conduits.

This procedure must be performed before mounting the Synergy Manager.

→ **To open conduit drill guides:**

1. Ensure that the Safety Switch is set to OFF (0) and ON/OFF/P switch of the Synergy Manager is in OFF position.
2. Remove the screws securing the DC and AC panels and remove the panels from the bottom of the Synergy Manager enclosure.



CAUTION!

To avoid damage to the internal part of the Synergy Manager, always remove plates from unit before drilling holes.



NOTE

Unused conduit openings should always be sealed.

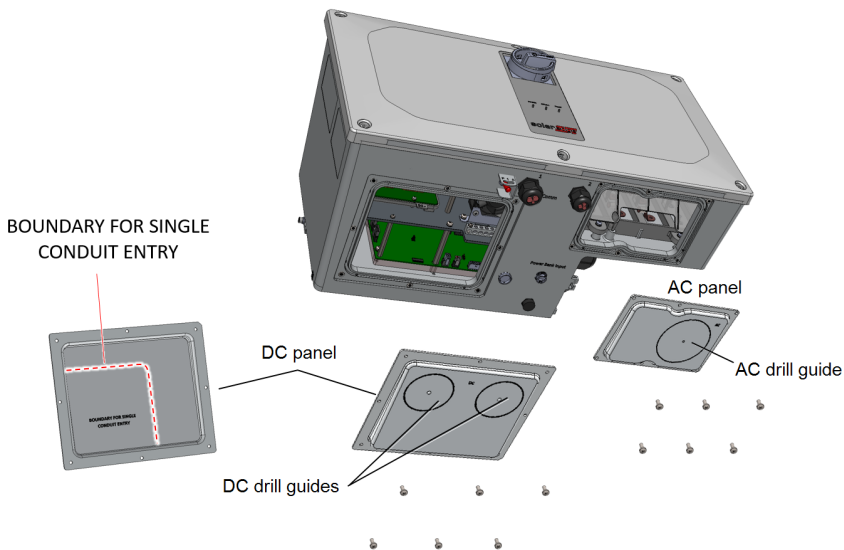

Figure 14: AC and DC panels with drill guides at the bottom of the Synergy Manager

3. Locate the drill guides for conduits on the DC and AC panels. Drill entry hole(s) for up to 2" conduit on the DC panel and 2.5" on the AC panel or drill entry hole for a single conduit, within the boundary marked on the inner side of the DC panel (see Figure 14).



NOTE

In some models, the DC panel has three drill entry hole(s) for up to 3" conduits.

4. Position the DC and AC panels back at the bottom of the Synergy Manager and torque the screws to 1.9 lb.*ft.

Mounting and Connecting the Synergy Manager and Synergy Units

This section provides instructions for vertical installation of the inverter and horizontal Inverter installed horizontally on a flat surface.

NOTE



Make sure the mounting surface or structure can support the weight of 82 kg (for inverter with two Synergy Units) or 114 kg (for inverter with three Synergy Units) of the inverter and brackets. Make sure that the mounting surface is at least 100.8 cm / 39.68" x 114.5 cm / 45".

CAUTION!

HEAVY OBJECT. To avoid muscle strain or back injury, use proper lifting techniques, and if required - a lifting aid.

**ATTENTION**

Objet lourd. Pour éviter la fatigue musculaire ou des blessures au dos, utilisez des techniques de levage appropriées et, si nécessaire - un auxiliaire de levage lors du retrait.

CAUTION!

SolarEdge inverters and Power Optimizers can be installed at a minimum distance of 50 m / 164 ft from the shoreline of an ocean or other saline environment, as long as there are no direct salt water splashes on the inverter or Power Optimizer.



For SolarEdge inverters installed at a distance of 200 m / 655 ft or closer to the shoreline, special brackets purchased separately from SolarEdge and SS304 stainless screws are required. For details, please contact your local sales representative.

ATTENTION!

Les onduleurs SolarEdge peuvent être installés à une distance minimum de 50m de la ligne d'eau de l'océan ou autre environnement salin, tant qu'il n'y a pas d'éclaboussements d'eau salée directs sur l'onduleur.

Pour les onduleurs SolarEdge installés à une distance de 200 m ou moins du rivage, des supports spéciaux achetés séparément auprès de SolarEdge et des vis inox SS304 sont nécessaires.

→ **To mount the inverter:**

1. Determine the inverter mounting location on a wall or stud framing. It is recommended to mount the inverter in a location protected from direct sunlight.

NOTE

When installing the inverter on a stud framing or a rail, avoid wobbly installation by adding back support at the lower back side of the Synergy Manager and Synergy Units (See *Figure 15*)

2. Allow for proper heat dissipation, follow the guidelines specified in [Application Note - Clearance Guidelines](#).

**NOTE**

Some Inverter models are provided with only two Synergy Units.

3. Level the mounting template horizontally against the wall and mark the drilling hole

locations for the bracket of the Synergy Units (see pencil icons in *Figure 15*).

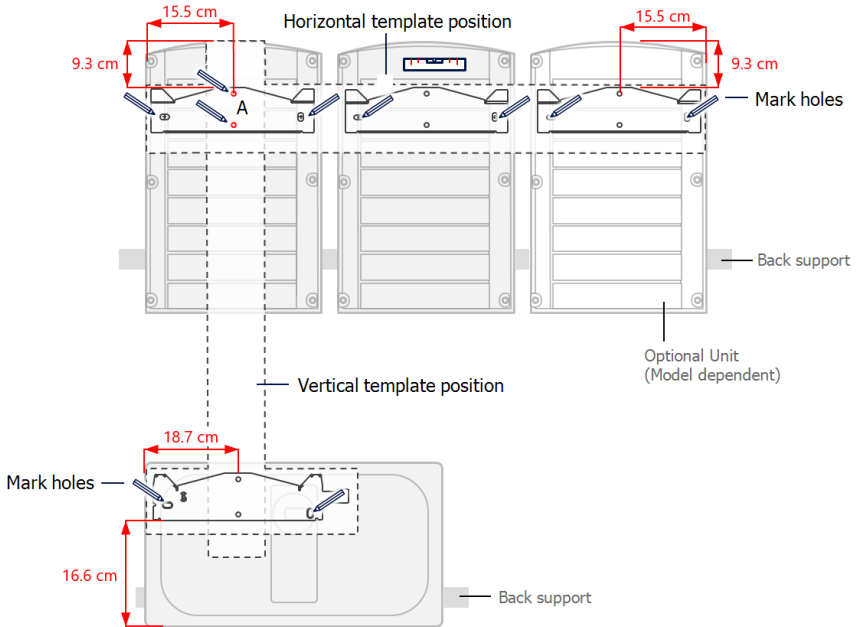

Figure 15: Marking the drilling holes locations

4. Place the mounting templates vertically against the wall and mark the drilling hole locations for the bracket of the Synergy Manager. Make sure that the template aligns with the two drilling holes marked A.
5. Drill two holes for each bracket and mount the brackets.
6. Position and secure the mounting brackets to the wall using at least two screws per bracket. Tighten the screws all the way and verify that the brackets are firmly attached to the mounting surface.
7. Mount the Synergy Units:



NOTE

When installing the Synergy Units, always install the center Synergy Unit first.

- Lift the Synergy Unit from the sides, or hold it at the top and bottom of the unit to lift into place.
- Align the two indentations in the enclosure with the two triangular mounting tabs of the bracket, and lower the unit until it rests on the bracket evenly (see *Figure 17*).

- For the right or left Synergy Units, insert only one screw through the outer (exposed) side of the unit and into the bracket. Tighten the screws to a torque of 2.9 lb.*ft (see *Figure 16*).

**NOTE**

For the center Synergy Unit, use both side screws.

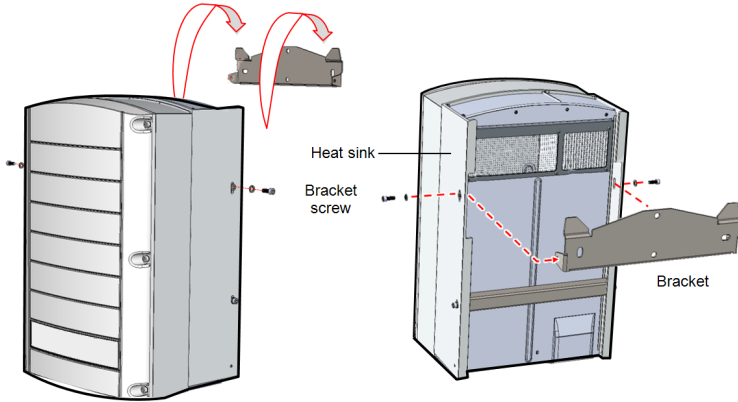

Figure 16: Hanging the Synergy Unit

- Hang the Synergy Manager:
 - Lift the Synergy Manager from its sides.
 - Align the two indentations in the enclosure with the two triangular mounting tabs of the bracket, and lower the unit until it rests on the bracket evenly (see *Figure 17*).
 - Insert the supplied bracket screw through the right side of the heat sink and into the bracket.

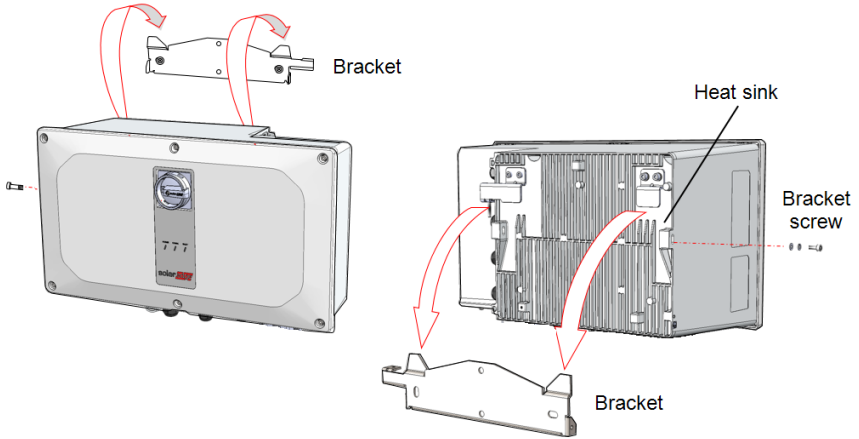

Figure 17: Hanging the Synergy Manager

Horizontal Mounting of the Inverter

The inverter can be installed horizontally, on a flat surface, at any tilt above 10° (see *Figure 18*). The inverter can be installed under or near the PV modules, thus saving roof space and using the PV modules for shading the inverter.

For more information on horizontal mounting, refer to [Horizontal Mounting of Three Phase Inverters](#).

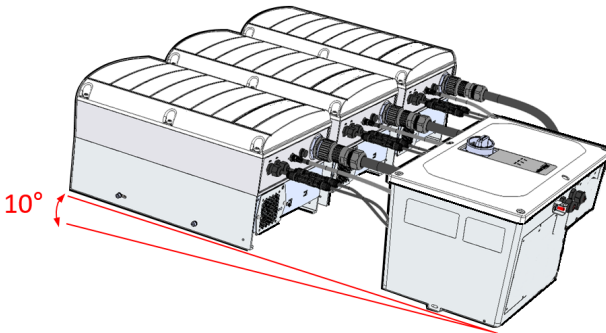

Figure 18: Horizontal mounting of the Inverter

Chapter 4: Connecting PV Modules and AC to the Synergy Manager

This section describes how to connect the inverter to the PV modules and to the AC.

Connecting PV Modules to the Synergy Manager

The Synergy Manager is designed to directly connect up to 12 PV strings or up to three PV arrays via an external combiner box.

CAUTION!



When installing a system with more than 3 PV strings per a single Synergy Unit (whether connected directly or via a combiner box), fuses are required. In SolarEdge system, 25A fuses must be used (See *Figure 19* and *Figure 20*)

Figure 19 shows the connection of PV strings and *Figure 20* shows the connection of PV arrays to the Synergy Manager.

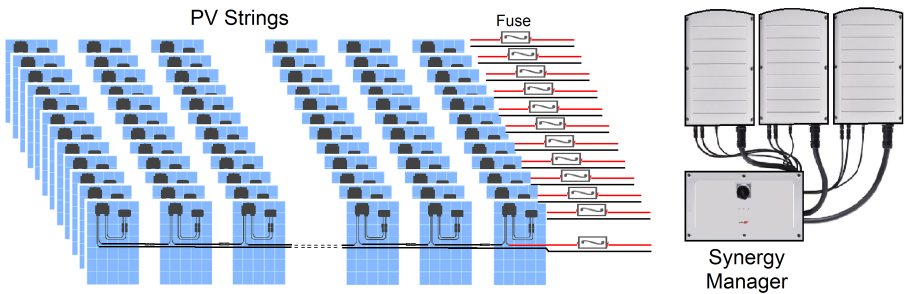

Figure 19: Connection of PV strings to the Synergy Manager

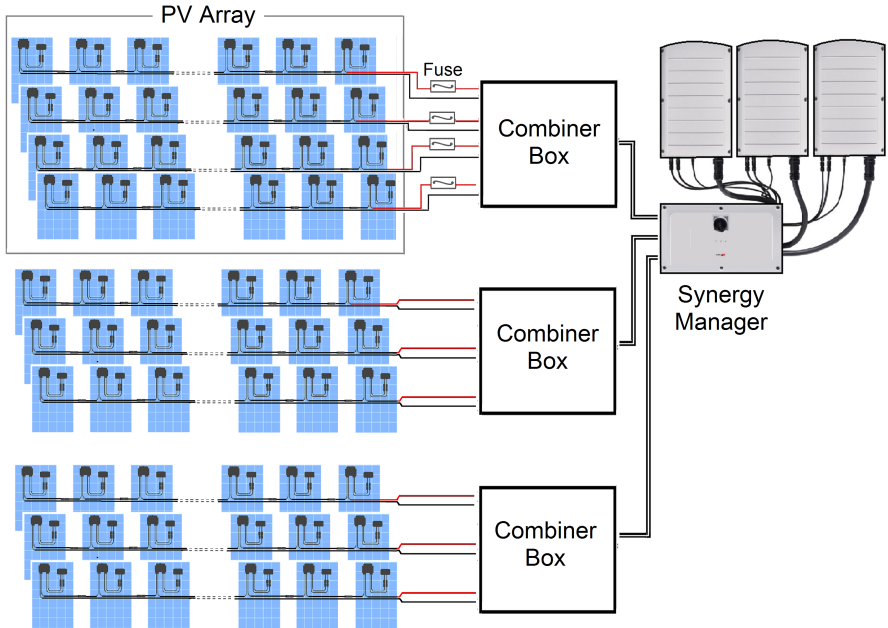

Figure 20: Connection of PV arrays to the Synergy Manager

Connection of PV arrays to the Synergy Manager is performed via a combiner box.

A combiner box is an electrical distribution box that may also host DC circuit breakers. The main purpose of the box is to combine multiple parallel strings of PV modules in the system into a single DC output. This DC output is then connected to a single input in the Synergy Manager of the inverter.

The combiner box should be installed and connected before connecting to the Synergy Manager. This simplifies the commissioning of the inverter by allowing testing and servicing the inverter.

Connection Methods

The Synergy Manager connects to the solar panels by the following interface methods:

- DC input terminals for three PV arrays inside the Synergy Manager
- DC input terminals (spring-clamps) for 12 PV strings inside the Synergy Manager

The DC Disconnect Switch of the Synergy Manager disconnects all ungrounded DC conductors in compliance with the National Electric Code (NEC; Specifically NEC690.35, which addresses ungrounded PV arrays). The Synergy Manager is rated to the maximum operating conditions of the inverter.

Figure 21 shows the various methods of connection of DC from the PV strings and PV arrays to Synergy Manager.

Synergy Manager with 12 PV Strings

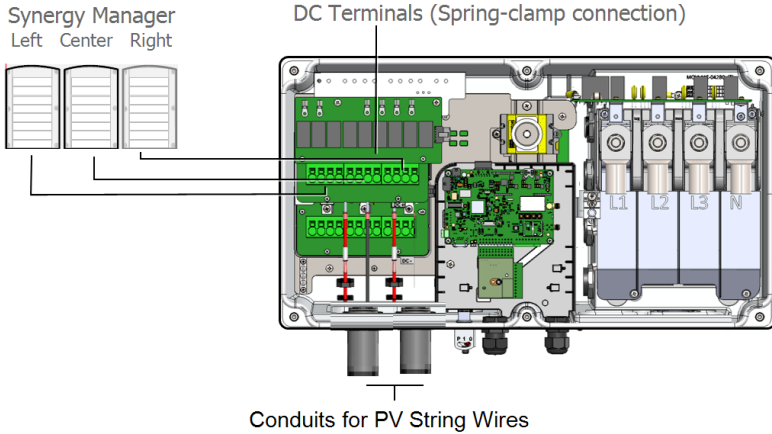

Synergy Manager with Three PV Arrays

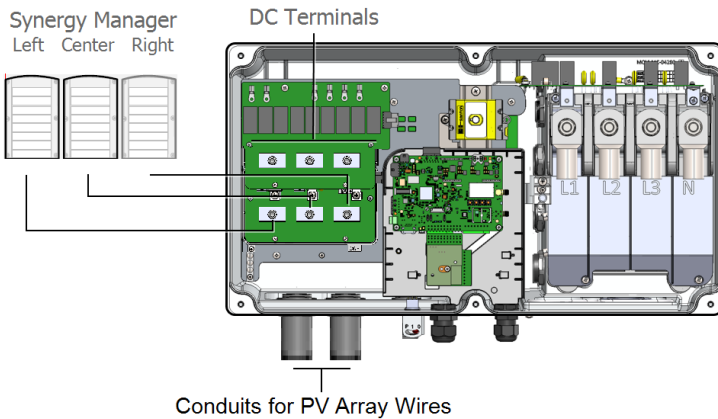

Figure 21: Connecting methods of PV Strings and PV arrays to Synergy Manager

NOTE



SolarEdge fixed input Voltage architecture enables parallel PV strings to be of different lengths. Therefore, they do not need to have the same number of Power Optimizers as long as the length of each PV string is within the permitted range.

- c. Insert the wire into the top opening (see *Figure 22*).
- d. Remove the screwdriver – the wire is automatically clamped.

**CAUTION!**

Ensure that the Plus (+) wire is connected to the + terminal and that the Minus (-) wire is connected to the Minus (-) terminal connector.

ATTENTION!

Veillez à ce que le câble Plus (+) soit connecté au terminal + et que le câble - soit connecté au connecteur terminal.

6. Close the Synergy Manager cover and secure it by tightening the six screws to a torque of 2.6 ft.*lb.
7. Ensure proper conduit sealing; inspect the entire conduit run and use standard conduit sealants to avoid water penetration.

Connecting PV Arrays to the Synergy Manager

When connecting cables from a combiner box, ensure that the cable pairs of the PV arrays are marked with DC+ and DC- labels.

→ To connect the PV arrays to a Synergy Manager with DC wire terminals:

1. Route the DC wires through the DC conduit.

NOTE



Use wires with 4 to 2 AWG cross section conductor.

When using fine stranded wires, crimp ferrules on wires.

2. Fasten the conduit nut and connect the 4-14 AWG ground wire of the conduit nut to the Grounding terminal block (bus bar) in the Synergy Manager. Fasten the screw of the bus bar to a torque of 2.2 lb.*ft.

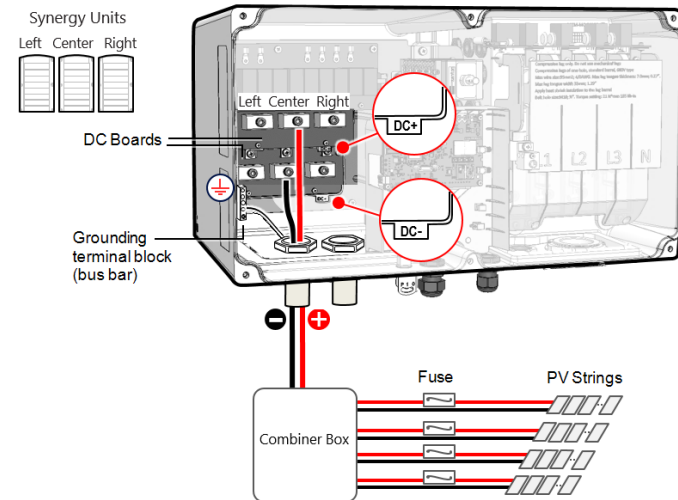

Figure 23: Connecting PV Arrays to the Synergy Manager

3. Loosen the Allen screws of the DC terminals.
4. Strip 7.9" / 200 mm of insulation from the DC wires.

NOTE

Before connecting aluminum wires to the terminals:



- a. Remove oxide from the exposed wires with emery paper or a steel wire brush
- b. Clean dust with a cloth and Isopropyl alcohol (IPA)
- c. Coat wires with a designated antioxidant aluminum wire grease immediately after cleaning

5. Route the DC wires to the DC+ and DC- terminals on the DC+ and DC- boards of the Synergy Manager (see DC+ and DC- labels on DC boards).

CAUTION!

The DC boards have three pairs of DC terminals. Each pair is connected to a single Synergy Unit (Left, Center and Right).

When installing a system with more than 3 PV strings per a single Synergy Unit (whether connected directly or via a combiner box), fuses are required. In SolarEdge system, 25A fuses must be used (see *Figure 23*).

NOTE

Functional electrical Earthing of DC-side negative or positive poles is prohibited because the inverter has no transformer. Grounding (earth ground) of module frames and mounting equipment of the PV string modules is acceptable.

6. Insert the DC wires into the DC terminals and fasten the Allen screw to a torque of 3.7 ft.*lb for 4 AWG wires or 5.9 ft.*lb for 3 to 2 AWG wires.

**CAUTION!**

Ensure that each Plus (+) wire is connected to its corresponding (-) terminal.

ATTENTION!

Veillez à ce que le câble Plus (+) soit connecté au terminal + et que le câble - soit connecté au connecteur terminal.

NOTE

For systems with four PV strings per unit or more, fuses may need to be installed in both the positive and negative conductors as required by NEC Article 690.9. For more information, refer to the "String Fusing Requirements in SolarEdge Systems" technical note at http://www.solaredge.com/files/pdfs/string_fusing_requirements.pdf.



7. Close the Synergy Manager cover and secure it by tightening the six screws to a torque of 2.6 ft.*lb.
8. Ensure proper conduit sealing; inspect the entire conduit run and use standard conduit sealants to avoid water penetration.

Connecting Ground and AC Wires to the Synergy Manager

This section describes how to connect AC and Ground (also referred to Protective Earth - PE) to the Synergy Manager.

For recommended circuit breaker size per model, refer to: Application Note:

[Determining the Circuit Breaker Size.](#)

The following wire configurations can be used to connect the Synergy Manager:

- L1, L2, L3, PE wires
- L1, L2, L3, N, PE wires



WARNING!

To avoid shock hazard conditions, the PE wire must be connected to the inverter before connecting the AC wires.

AVERTISSEMENT!

Pour éviter les risques d'électrocution, le fil de terre doit être connecté à l'onduleur avant de connecter les fils CA.

- Use AC line wires with a maximum of 4/0 AWG cross section conductor
- Use PE wire with a maximum of 1/0 AWG cross section conductor
- Use a PE wire with an outer diameter to a torque of 0.4 to 0.43"



CAUTION!

Over-current protection for the AC output must be provided by the installer.

Connecting Protective Earth (PE)



WARNING!

Turn OFF the AC before connecting the AC terminals. When connecting equipment Grounding wire, connect it before connecting the AC Line and Neutral wires.

AVERTISSEMENT!

Éteignez l'alimentation CA avant de connecter les bornes CA. Si vous souhaitez relier le fil de mise à la terre de l'équipement, faites-le avant de connecter la ligne CA et les fils du neutre.

→ To connect Protective Earth (PE) to the Synergy Manager:

1. Turn OFF and secure the main AC circuit breaker in OFF position at the circuit breakers panel.
2. Release the six Allen screws and carefully remove the cover of the Synergy Manager.

CAUTION!



When removing the cover, make sure not to damage internal components. SolarEdge will not be held responsible for any components damaged as a result of incautious cover removal.

ATTENTION!

Lors du retrait du couvercle, assurez-vous de ne pas endommager les composants internes. SolarEdge ne peut être tenue pour responsable des composants endommagés à la suite d'une imprudence dans le retrait du couvercle.

3. Insert the conduit with the AC lines and PE wire through AC opening at the bottom of the Synergy Manager.



CAUTION!

Ground the conduit nut if required by regulation.

Mettez à la terre l'écrou du conduit si la réglementation l'exige.



NOTE

Connect the equipment grounding before connecting the AC wires to the AC terminal block.

Veillez à relier le conducteur de PE (la terre) avant de connecter les fils CA au bornier CA.

4. Strip 0.4 to 0.43" / 10 to 11 mm of insulation from the PE wire.
5. Connect the PE wire to the PE terminal and fasten the Allen screw to a torque of 3.7 lb.*ft for wires of 10 to 4 AWG or 5.9 lb.*ft for wires of 3 to 1/0 AWG.

NOTE

Before connecting lugs to aluminum wires:



- a. Remove oxide from the exposed wires with emery paper or a steel-wire brush
- b. Clean dust with a cloth and Isopropyl alcohol (IPA)
- c. Coat wires with a designated antioxidant aluminum wire grease immediately after cleaning

**NOTE**

Use ferrule when connecting a fine stranded wire.

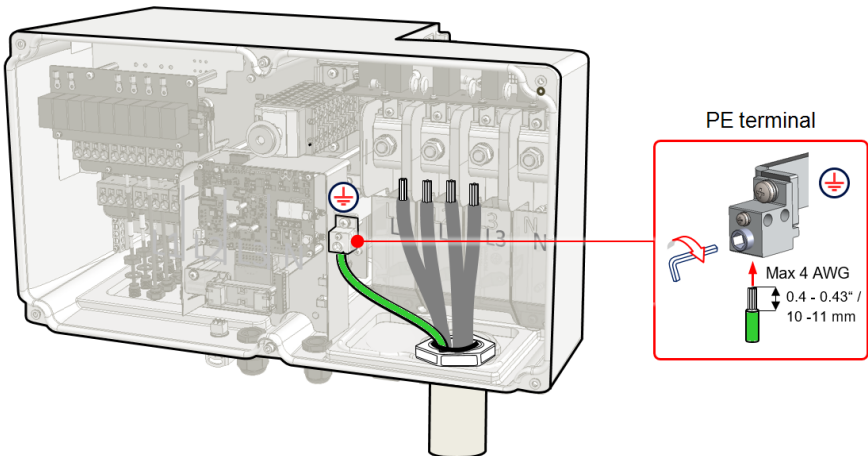

Figure 24: Connecting the Protective Earth (PE) wire

**NOTE**

Ground the conduit nut if required by regulation.

→ To connect AC wires to the Synergy Manager:

1. Verify that the main AC circuit breaker is in OFF position at the circuit breakers panel.
2. Remove the upper cover of the AC terminal block.

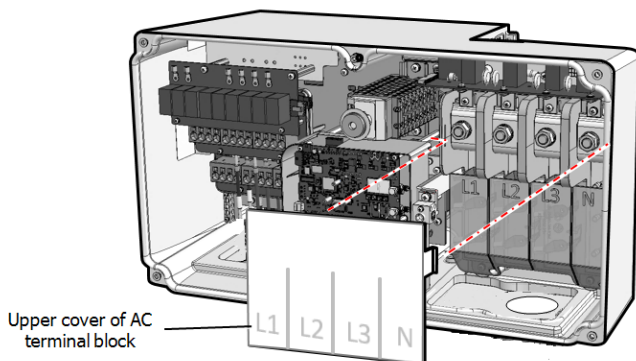

Figure 25: Upper cover of AC terminal block

3. Route the AC wires through the AC conduit.
4. Fasten the conduit nut inside the Synergy Manager.



NOTE

Ground the conduit nut if required by regulation.

5. Strip the required length of insulation from the AC cable and AC wires.

NOTE

Before crimping lugs on aluminum wires:



- a. Remove oxide from the exposed wires with emery paper or a steel wire brush
- b. Clean dust with a cloth and Isopropyl alcohol (IPA)
- c. Coat wires with a designated antioxidant aluminum wire grease immediately after cleaning

6. Crimp lugs on the AC wires.

CAUTION!



For aluminum wires, USE ONLY aluminum lugs.
For copper wires, USE ONLY copper tin-plated lugs.

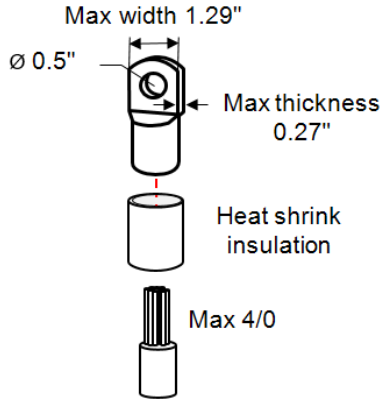

Figure 26: Crimping a lug on an AC wire

Lug parameters:

- Bolt hole diameter size: 0.5"
 - Compression lugs of the one-hole, standard barrel, 600V type.
 - Maximum wire size: 4/0 AWG 120 mm²
 - Maximum lug tongue thickness: 0.27 "
 - Maximum lug tongue width: 1.29 "
7. Use heat shrink to isolate the lug barrels.
 8. Remove the nut of the AC terminals.
 9. Connect the lug of the AC wires according to the labels on AC terminal block. Fasten the nut of the AC terminals to a torque of 15.4 lb.*ft.



NOTE

For easy installation of the AC wires, start connecting the wires from left to right: L1 → L2 → L3 → N (See Figure 27).

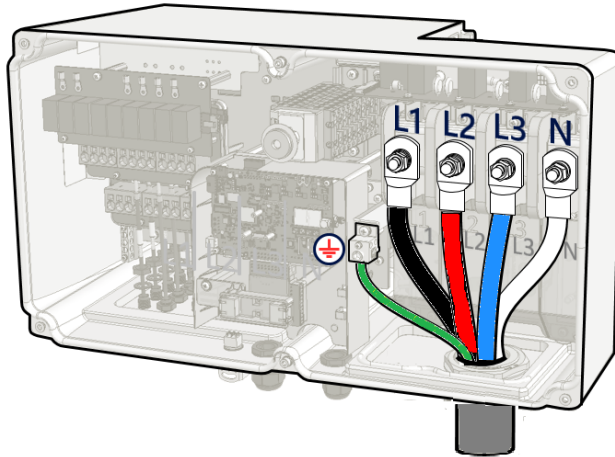

Figure 27: Connecting AC wires to the AC terminals

10. Place the upper cover of the AC terminal block and push until a lock click is heard. Close the Synergy Manager cover and secure it by tightening the six screws to a torque of $1\text{b}\cdot\text{ft}2.6$.

Chapter 5: Activating, Commissioning and Configuring the System

After the solar system is installed, it is important to activate and commission the solar system. Activation and commission of the system is performed using the inverter SetApp mobile application.

The solar system can be activated and commissioned in the following stages of system stage:

- On-grid: The inverter is connected to a utility grid
- Pre-commissioning (Off-grid): The inverter is not connected to a grid to enable:
 - Early validation and fault detection of system components, such as inverters, Power Optimizer, PV modules before activation
 - Ensure system integrity before connecting to the grid

During the activation and commissioning, the inverter discovers and communicates with all connected components in the solar system, such as: optimizers, peripheral communication devices and other linked inverters. When commissioning is performed, the user is required to set the grid parameters and backup Voltage information (if used).

Before starting the activation and commissioning, verify the all the communication hardware is properly connect. For communication options, refer to: *Setting Up Communication to the Monitoring Platform - Inverter Extended Version* on page 1.

Before arriving at the site, download SolarEdge SetApp application to your mobile device from Apple App Store or Google Play .

Before activation and commissioning, download the SetApp application from:



For downloading SetApp, Internet connection, one-time registration and logging are required. No registration is required for using the SetApp.

On-grid Commissioning of the inverter

Step 1: Activating the Installation

During system activation, a Wi-Fi connection is created between the mobile device and the inverter and the system firmware is upgraded.

Before activation

- Download, register (first time only) and login to SetApp on your mobile device. Verify that the application is updated with the latest version.
- If applicable, turn on all devices (battery, Energy Meter, Backup Interface) connected to the inverter, so that the devices may be auto-detected.

→ To activate the inverter:

1. Turn-on the AC circuit breaker on the main distribution panel.
2. Turn-on the DC Disconnect Switch (if applicable).
3. Open SetApp and follow the on-screen instructions (scan the inverter barcode; move the ON/OFF/P switch to P position for 2 seconds and release).
SetApp creates a Wi-Fi connection, upgrades the inverter firmware and activates the inverter.
4. When the activation is complete, do one of the following:
 - Select **Connect to Another Device** to continue activating additional inverters.
 - Select **Start Commissioning** for pairing and other system configuration.

Step 2: Commissioning and Configuring the Installation

This section describes how to use the SetApp menus for commissioning and configuring the inverter settings.

Menus may vary in your application depending on your system type.

→ To access the Commissioning screen:

Do one of the following:

- During first time installation: Upon activation completion, in the SetApp, tap **Start Commissioning**.

- If the inverter has already been activated and commissioned:
 - If not already ON - turn ON AC to the inverter by turning ON the circuit breaker on the main distribution panel.
 - Open SetApp and follow the on-screen instructions (scan the inverter QR code, move the ON/OFF/P switch to P position for 2 seconds and release).
The mobile device creates a Wi-Fi connection with the inverter and displays the main Commissioning screen.

Setting Country, Grid and Language

The inverter must be configured to the proper settings in order to ensure that it complies with the country grid code and functions. Unless these settings are selected, the inverter will not start production.

1. From the **Commissioning** screen, select **Country & Grid**.
2. From the **Country & Grid** drop-down list, select the required option and tap **Set Country & Grid**.
3. If relevant, from the **Language** drop-down list, select your language and tap **Set Language**.
4. To save the information to a read-only file, tap the **PDF** icon (iOS) or the **JPEG** icon (Android) at the bottom of the screen.

Pairing

1. From the **Commissioning** menu, select **Pairing**.
2. Tap **Start Pairing**.
3. When **Pairing Complete** is displayed, the system startup process begins:
Since the inverter is ON, the Power Optimizers start producing power and the inverter starts converting AC.

WARNING!



When you turn ON the ON/OFF/P switch, the DC cables carry a high Voltage and the Power Optimizers no longer output a safe output.

AVERTISSEMENT!

Après avoir mis l'interrupteur ON/OFF/P de l'onduleur monophasé sur ON, les câbles DC portent une haute tension et les optimiseurs de puissance ne génèrent plus la tension de sécurité.

When the inverter starts converting power after the initial connection to the AC, the inverter enters Wake up mode until its working voltage is reached. This mode is indicated by the flickering green inverter LED.

When working voltage is reached, the inverter enters Production mode and produces power. The steadily lit green inverter LED indicates this mode.

4. Tap **OK** to return to the **Commissioning** menu.

Communication

Communication settings can be configured only after communication connections are complete. Refer to *Setting Up Communication to the Monitoring Platform* on page 1.

- Select **Monitoring Communication** to configure communication with the monitoring platform.
- Select **Site Communication** to configure communication between multiple SolarEdge devices or external non-SolarEdge devices, such as batteries or loggers.

Power Control

Power control options are detailed in the *Power Control Application Note*, available on the SolarEdge website at: https://www.solaredge.com/sites/default/files/application_note_power_control_configuration.pdf.

For P(Q) diagram refer to: https://www.solaredge.com/sites/default/files/application_note_p_q_diagram_of_se_inverters_en_and_na.pdf.

NOTE



SolarEdge inverters with “Grid Support” functionality (as marked on the inverter certification label), are compliant with UL 1741 Supplement A. The functionality is built into the inverter and no additional external device is required.

Step 3: Verifying Proper Activation and Commissioning

1. Select **Information** and verify that the correct firmware versions are installed on each inverter.
2. Select **Status** and verify that inverter is operating and producing power.
3. Verify that additional configurations were properly set by viewing the relevant Status screens.
4. Verify that the green inverter LED is steadily lit.

Your SolarEdge power harvesting system is now operational.

Pre-commissioning (Off-Grid)

The following items are required for Pre-commissioning:

- Mobile device with SolarEdge SetApp application
- Power bank: 60W output port, USB-C Power Delivery (PD): 20V 3A (not provided)
- USB cable: 3.3 ft (1 meter), USB-C to USB-C (not provided)



IMPORTANT NOTE

Commissioning should be performed in full daylight.



NOTE

When pre-commissioning multiple inverters, each inverter need to be commission individually.

→ To pre-commission the inverter:

1. Turn OFF and secure the AC circuit breaker in OFF position in the circuit breakers panel.
2. Verify that SolarEdge SetApp is installed on your mobile device.
3. Turn the DC Disconnect Switch on the Synergy Manager to ON position (if applicable).
4. Remove the cover from the Power Bank input port at the bottom of the Synergy Manager. Connect the USB cable between the Power Bank and the input port - Upon connection, all LEDs light steady for one minute, and then alternate blue / green.



NOTE

Alternating red / blue LEDs indicate a problem with the power bank.

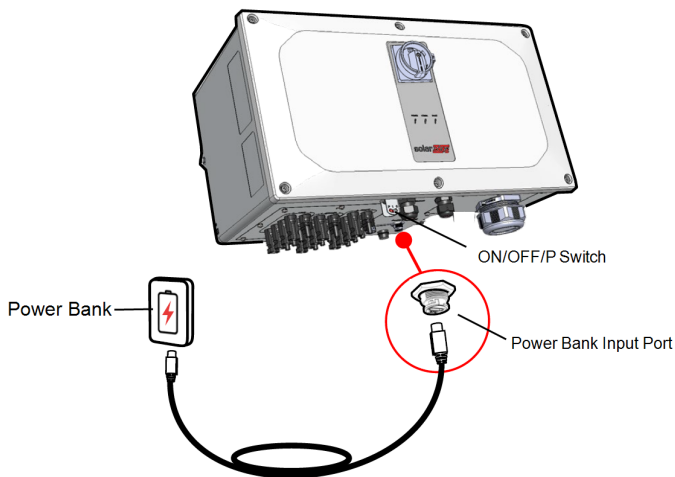

Figure 28: Pre-commissioning the inverter

5. Start SetApp on your mobile device and follow the on-screen instructions.
6. When instructed, hold the ON/OFF/P Switch in P position and release within two seconds and continue to follow the on-screen instructions.
7. Disconnect the power bank and cover the power bank input port.
8. Turn-off the DC Disconnect Switch and the ON/OFF/P Switch.
9. Wait until the inverter turns-off (all LEDs turn-off).

Reporting and Monitoring Installation Data

Monitoring the site requires connecting the inverter to the monitoring platform, using any of the wired or wireless options available from SolarEdge. Refer to *Setting Up Communication* on page 1.

The Monitoring Platform

The monitoring platform provides enhanced PV performance monitoring and inverter yield assurance through immediate fault detection and alerts at the module, PV array and system level.

Using the platform, you can:

- View the latest performance of specific components.
- Find under-performing components, such as modules, by comparing their performance to that of other components of the same type.

- Pinpoint the location of alerted components using the physical layout.

The monitoring platform enables accessing site information, including up-to-date information viewed in a physical or logical view:

- **Logical Layout:** Shows a schematic tree-layout of the components in the system, such as: inverters, Power Optimizers, PV arrays, modules, meters and sensors, as well as their electrical connectivity. This view enables you to see which modules are connected in each PV array, which PV arrays are connected to each inverter, and so on.
- **Physical Layout:** Provides a bird's eye view of the actual placement of modules in the site, and allows pinpoint issues to the exact location of each module on a virtual site map.

If you do not report the mapping of the installed Power Optimizers, the monitoring platform will show the logical layout, indicating which Power Optimizers are connected to which inverter, but will not show PV strings or the physical location of Power Optimizers.

The monitoring platform includes a built-in help system that guides you through the monitoring functionality.

For more information, refer to <https://www.solaredge.com/products/pv-monitoring#/>.



Creating Logical and Physical Layout using Installation Information

To display a logical layout, insert in the new site created in the monitoring platform. When the communication between the and the monitoring server is established, the logical layout is displayed.

To display a physical layout, you need to map the locations of the installed power optimizers. To map the locations, use one of the methods described in the next sections.

Designer

Designer recommends inverter and Power Optimizer selection per site size and enables report generation. You can create a project in Designer and export the site design with the PV array layout to the monitoring platform.

For more information, refer to

<https://www.solaredge.com/products/installer-tools/designer#/>.



Physical Layout Editor

1. If you are a registered installer, access the monitoring platform site creation page at <https://monitoring.solaredge.com/solaredge-web/p/home#createSites>. If you have not yet signed up, go to <https://monitoring.solaredge.com/solaredge-web/p/createSelfNewInstaller>.
2. Fill out all required information in the screen, which includes information about your installation, as well as details about its logical and physical mapping.



Signaling Options

Alternative Power Source

Energy-generation systems (such as PV inverters) connected to the grid may consist of different types of energy generating sources.

In some cases, when grid power is disconnected, PV inverters operate in parallel with other voltage sources, such as generators.

When inverters operate concurrently with generators, they may be subjected to voltage and frequency fluctuations that exceed trips, which are preset according to regional grid connection requirements. To support simultaneous operation of the inverter and a generator, the inverter extends its Voltage and frequency operating range once it receives a Power Reduction Interface (PRI) signal indicating that grid power is unavailable ("Alternative Power Source mode"). When the grid power is restored, the inverter automatically reverts to its default country setting, which includes the original Voltage and frequency operating range.

Figure 29, shows an Example of Alternative Power Source System.

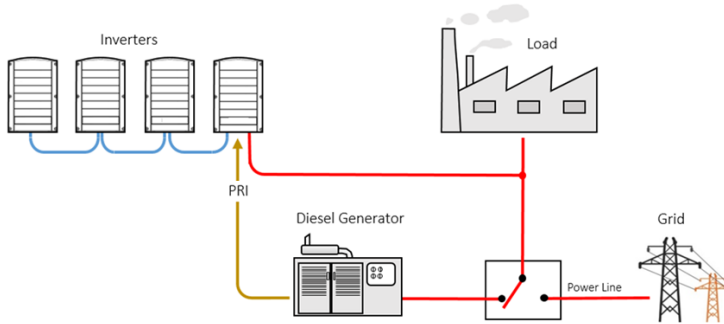

Figure 29: Example of Alternative Power Source System

The Power reduction Interface (PRI) terminal block on the communication board (See *Figure 30*) is used signaling the inverter to switch to Alternative Power Source mode.

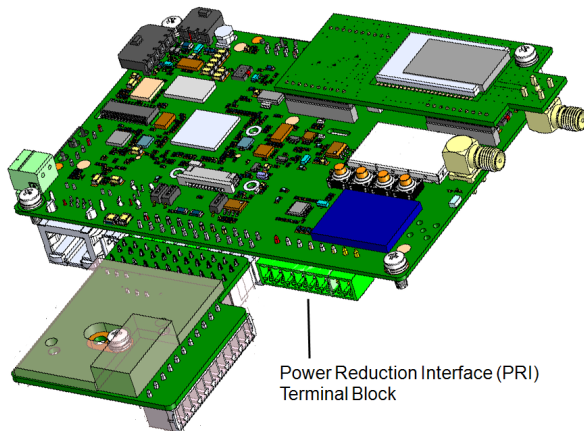

Figure 30: PRI Terminal Block Location on the Communication Board of the Inverter

For detailed connection and configuration of the inverter in alternative power source mode, refer to: <https://www.solaredge.com/sites/default/files/se-inverter-support-of-voltage-sources.pdf>

Appendix A: Errors and Troubleshooting

This chapter describes how to troubleshoot general system problems. For further assistance, contact SolarEdge Support.

Identifying Errors

Errors may be indicated in various system interfaces: On the inverter bottom panel, a red LED indicates an error. In the monitoring platform and SetApp, errors are displayed with codes.

For more information on the codes displayed for error and warning messages, refer to https://www.solaredge.com/sites/default/files/troubleshooting_for_se_inverter_insallation_guide_addendum_na.pdf. This document describes errors that appear in SetApp, monitoring platform, and LCD (for inverters with LCD). To identify the error types, use the methods described below.



→ To identify the error type using the inverter LEDs:

1. Move the ON/OFF/P switch to **P** position for **2 seconds** and release it.
2. Observe the LED lights and use the following table to identify the error type. For more information, refer to:

<https://www.solaredge.com/us/leds>.



Error Type	Inverter LED Color and State		
	Red	Green	Blue
Arc detected	ON	OFF	OFF
Isolation or RCD problem	Blinking	OFF	OFF
Grid error	OFF	ON	OFF
High temperature	OFF	Blinking	OFF
Pairing failed	OFF	OFF	ON
Other issue	OFF	OFF	Blinking

→ To identify the error type using the monitoring platform:

1. Open the site dashboard and click the **Layout** icon.
2. Right-click the inverter and select **Info** from the menu. The inverter details window is displayed.
3. Click the **Errors** tab. The list is displayed.

Power Optimizer Troubleshooting

Malfunction	Possible Cause and Corrective Action
Pairing failed	<p>Power Optimizers are shaded.</p> <p>If you connected the inverter to the monitoring platform, retry pairing remotely (during sunlight). Make sure to leave the inverter ON/OFF/P switch ON and that S_OK appears in the status screen.</p>
PV string Voltage is 0V	<p>Power Optimizer (s) output is disconnected.</p> <p>Connect all Power Optimizer outputs.</p>
PV string voltage not 0V but lower than number of Power Optimizers	<p>Power Optimizer(s) not connected in the PV string.</p> <p>Connect all Power Optimizers.</p>
	<p>Panel(s) not connected properly to Power Optimizer inputs (not applicable to smart modules).</p> <p>Connect the modules to the Power Optimizer inputs.</p>
	<p>PV string reverse polarity.</p> <p>Check PV string polarity using a voltmeter and correct if needed.</p>

Malfunction	Possible Cause and Corrective Action
<p>PV string Voltage is higher than number of Power Optimizers</p> <p>WARNING! If the measured voltage is too high, the installation may not have a safe low voltage. PROCEED WITH CARE! A deviation of $\pm 1\%$ per PV string is reasonable.</p> <p> AVERTISSEMENT! <i>Si la tension mesurée est trop haute, la tension basse de sécurité pourrait manquer dans l'installation. REDOUBLEZ DE PRECAUTION. Une déviation de $\pm 1\%$ par string est raisonnable.</i></p>	<p>Extra Power Optimizer(s) connected in the PV string (not applicable to smart modules). Check if an extra Power Optimizer is connected in the PV string. If not – proceed to next solution.</p> <p>A module is connected directly to the PV string, without a Power Optimizer (not applicable to smart modules). Verify that only Power Optimizers are connected in the PV string and that no module outputs are connected without a Power Optimizer. If the problem persists, proceed to the next step.</p> <p>Power Optimizer(s) malfunction.</p> <ol style="list-style-type: none"> 1. Disconnect the wires connecting the Power Optimizers in the PV string. 2. Measure the output voltage of each Power Optimizer to locate the Power Optimizer that does not output 1V safety Voltage. If a malfunctioning Power Optimizers located, check its connections, polarity, module, and Voltage. 3. Contact SolarEdge Support. Do not continue before finding the problem and replacing the malfunctioning Power Optimizer. If a malfunction cannot be bypassed or resolved, skip the malfunctioning Power Optimizer, thus connecting a shorter PV string.

Troubleshooting Communication

Troubleshooting Ethernet (LAN) Communication

The possible errors and their troubleshooting are detailed in the following table:

Error Message	Possible Cause and Troubleshooting
LAN cable disconnected	Physical connection fault. Check the cable pin-out assignment and cable connection.
No DHCP	IP settings issue. Check the router and configuration. Consult your network IT.
Configure Static IP or set to DHCP	
Gateway not responding	Ping to router failed. Check the physical connection to the switch/ router. Check that the link LED at the router /switch is lit (indicating phy-link). If OK - contact your network IT, otherwise replace the cable or change it from cross to straight connection.
No Internet connection	Ping to google.com failed. Connect a laptop and check for internet connection. If internet access is unavailable, contact your IT admin or your internet provider.

Troubleshooting RS485 Communication

➤ If the message **RS485 Leader Not Found** appears in the Status screen, check the connections to the leader device and fix if required.

➤ If after follower detection the number of followers displayed for the leader under **RS485-1 > Follower Detect** is lower than the actual number of followers, refer to the following application note to identify missing followers and troubleshoot connectivity problems:

https://www.solaredge.com/sites/default/files/troubleshooting_undetected_RS485_devices.pdf



Additional Troubleshooting

1. Check that the modem or hub/router is functioning properly.
2. Check that the connection to the internal connector on the communication board is properly done.
3. Check that the selected communication option is properly configured.
4. Use a method independent of the SolarEdge device to check whether the network and modem are operating properly. For example, connect a laptop to the Ethernet router and connect to the Internet.
5. Check whether a firewall or another type of network filter is blocking communication.

Appendix B: Adding Optional Components

This appendix describes the optional components available for the inverter. Before ordering component, verify that your inverter model supports the component and that the component is not already provided with the inverter.

Ordered Installation and replacement kits for components include procedures for removal and installation of the components.

NOTE



Replaced component or part may require being disposed according local regulations. If you wish to discard components or parts, contact your local authorities and ask for the correct method of disposal.

AC Surge Protection Device (SPD)

The AC SPD is a device designed to protect the inverter from Voltage spikes and surge attempts forming on the AC grid lines. The SPD limits the Voltage supplied to the inverter by either blocking or shorting to ground Voltages above a safe threshold. The SPD is installed inside the inverter and communicates with the SolarEdge Monitoring platform for reporting surge protection events and faults.

For installation and configuration of the AC SPD, refer to:

<https://www.solaredge.com/sites/default/files/se-synergy-manager-ac-spd-installation-guide.pdf>

DC Surge Protection Device (SPD)

The DC SPD is a device designed to protect the inverter from Voltage spikes and surge attempts, forming on the PV DC lines, mainly induces by lightning. The SPD limits the Voltage supplied to the inverter by either blocking or shorting to ground Voltages above a safe threshold. The SPD is installed inside the inverter and communicates with the SolarEdge Monitoring platform for reporting surge protection events and faults.

For installation and configuration of the DC SPD, refer to:

<https://www.solaredge.com/sites/default/files/se-synergy-manager-dc-spd-installation-guide.pdf>

Cellular Plug-in

The cellular plug-in provides wireless communication between the inverter and the SolarEdge monitoring platform. The Cellular Plug-in kit is provided with an antenna and user manual. For more information on the Cellular Plug-in, refer to:

https://www.solaredge.com/sites/default/files/cellular_gsm_installation_guide_for_inverters_with_setapp.pdf

<https://www.solaredge.com/sites/default/files/se-cellular-plug-in-for-inverters-with-setapp-installation-guide.pdf>

Appendix C: Mechanical Specifications

The following figure shows the dimensions of the Three Phase Inverter with Synergy Technology.

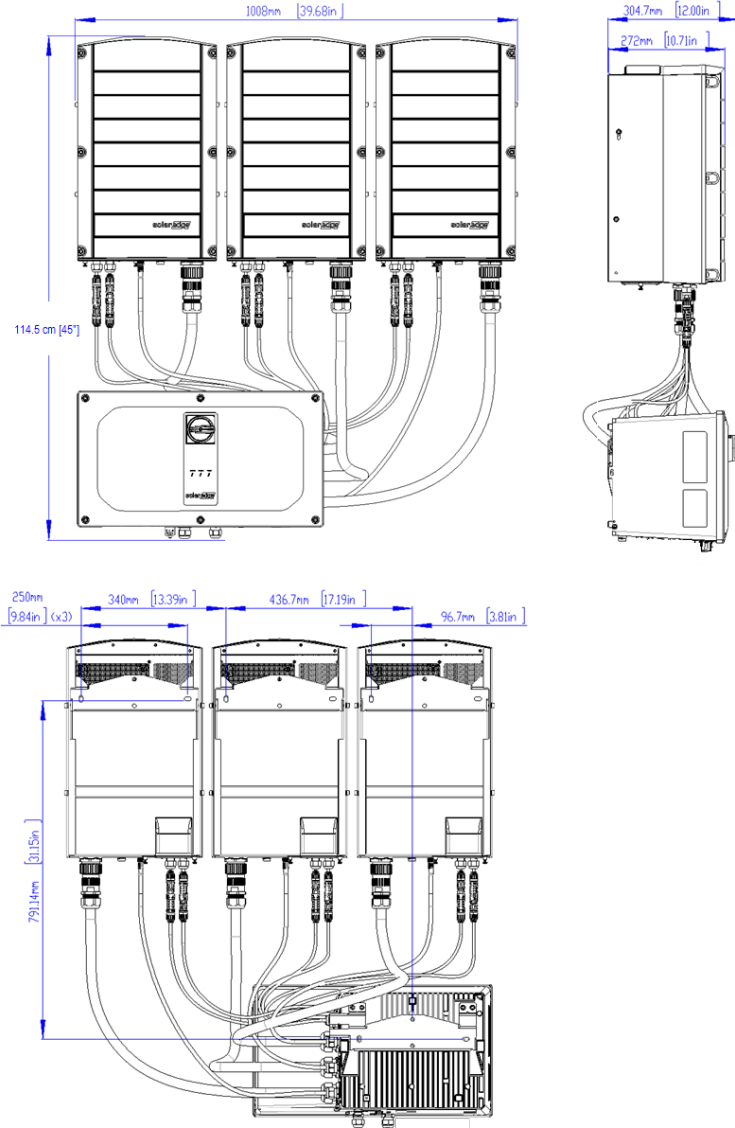

solaredge