

1. Accessories

Item	Description
A	AC Trunk Cable, 12/10 AWG Cable
B	M8 x 25 screws (Prepared by the installer)
C	Grounding Electrode
D	AC Trunk Connector
E	AC Trunk Port Cap
F	AC Trunk Port Disconnect Tool
G	AC Trunk End Cap
H	AC Trunk Connector Unlock Tool

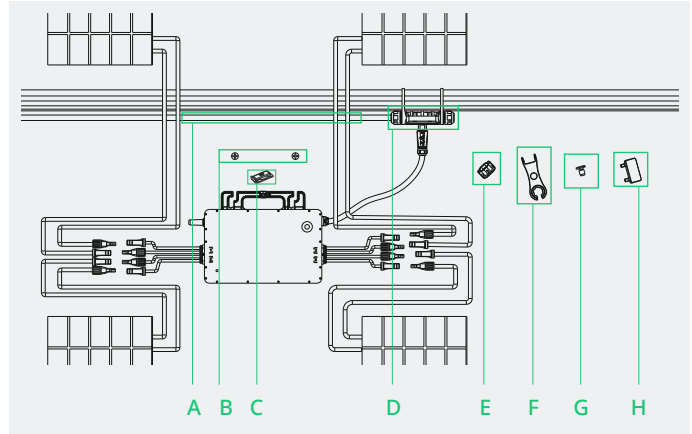

*Note: All accessories above are not included in the package and should be purchased separately.

2. Installation Steps

The order of Step 1 and Step 2 can be reversed according to your planned needs.

Step 1. Plan and install the Microinverter

A) Mark the position of each microinverter on the rail, according to the PV module layout.

B) Fix the screw on the rail.

C) Hang the microinverter on the screws, and tighten the screws. The silver cover side of the microinverter should be facing the panel.

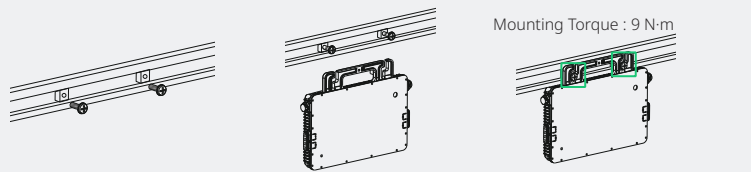

Note:

1. There is an earth wire inside the wire cable and the grounding can be done directly by this wire. If external grounding is needed, the grounding electrode, as shown on the right, can be used to bond the mounting bracket to the racking. Torque each grounding cleat screw to 2 N·m.
2. Install the microinverter and all DC connections under the PV module to avoid direct sunlight, rain exposure, snow buildup, UV, etc.
3. Leave at least 2 cm of space around the microinverter enclosure to ensure ventilation and heat dissipation.
4. Mounting torque of the 8 mm screws should be 9 N·m. Please do not over-torque.
5. Do not pull or hold the AC cable with your hand. Hold the handle instead.

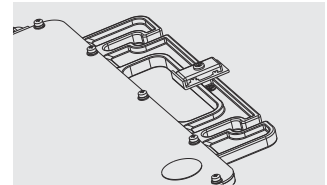

Step 2. Plan and build the AC Bus Cable

AC Trunk Cable is used to connect the microinverter to distribution box.

A) Select the appropriate AC Trunk Cable according to the spacing between microinverters. The connector spacing of the AC Trunk Cable should be close to spacing between microinverters to ensure that they are well-matched. (Hoymiles provides AC Trunk Cable with different AC Trunk Connector spacing.)

B) Determine how many microinverters you plan to install on each AC branch and prepare AC Trunk Connectors accordingly.

C) Take out segments of AC Trunk Cable as you need to make AC branch.

1) Disassemble the AC Trunk Connector and remove the cable.

- Use the AC Trunk Connector Unlock Tool to unlock the connector upper cover.

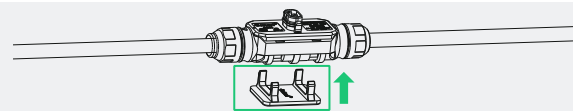

- Loosen the three screws with screwdriver. Untighten the cap and remove the cable.

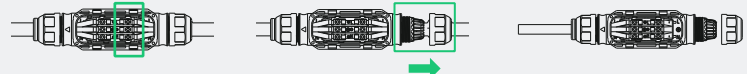

2) Install the AC Trunk End Cap at one side of AC Trunk Cable (The end of AC Trunk Cable)

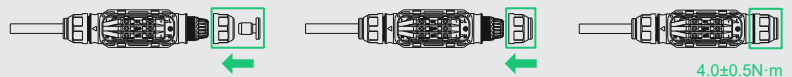

- Insert the AC Trunk End cap and screw the cap back to port, then tighten the cap.

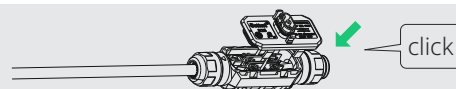

- Plug the upper cover back to the Trunk connector.

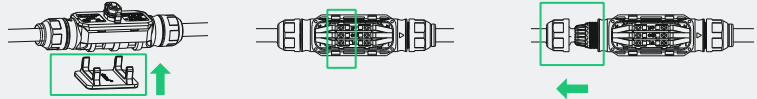
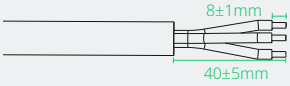
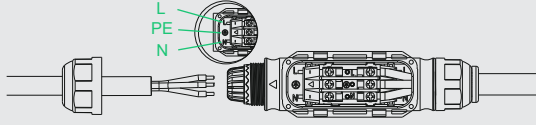
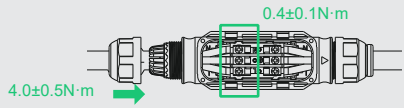

3) Install AC end cable on the other side of AC Trunk Cable (connected to the distribution box)

<p>- Unlock the port upper cover, loosen the screws with screwdriver and remove the extra cable. (Skip this step if there is no cable at this side.)</p>	
<p>- Prepare a segment of AC cable with suitable length to connect to the distribution box, with stripping requirements fulfilled.</p>	
<p>- Insert the cable into the cap in a way that the L, N and PE lines are in corresponding slots.</p>	
<p>- Tighten the screws and tighten the cap back to the port.</p>	
<p>- Plug the upper cover back to the Trunk connector.</p>	

Note:

1. Tightening torque of the cap: 4.0 ± 0.5 N·m. Please do not over-torque.
2. Torque of locking screw: 0.4 ± 0.1 N·m.
3. Do not damage the sealing ring in the AC Trunk Connector during disassembly and assembly.

D) Repeat the above steps, lay out the cable on the rail as appropriate so that the microinverters can be connected to the Trunk connectors.

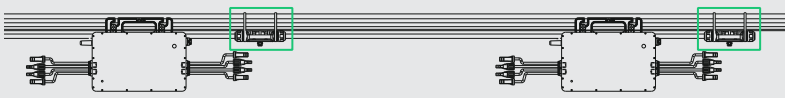
<p>E) Attach the AC Trunk Cable to the mounting rail and fix the cable with tie wraps.</p>	
--	---

Step 3. Complete the AC Connection

<p>A) Push the AC Sub Connector from microinverter to the AC Trunk Connector until it clicks.</p>	
---	--

B) Connect the AC end cable to the distribution box, and wire it to the local grid network.

<p>C) Please plug the AC Trunk Port Cap in any vacant AC Trunk Port to make it water and dust-proof.</p>	
--	--

Note:

1. Make sure that the AC Trunk Connectors are kept away from any water-channeling surface.
2. In case you need to remove the inverter AC cable from AC Trunk Connector, please use the AC Trunk Port Disconnect Tool and insert the tool into the side of AC Sub Connector to complete the removal.

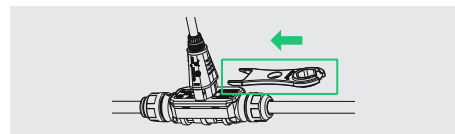

Step 4. Create an Installation Map

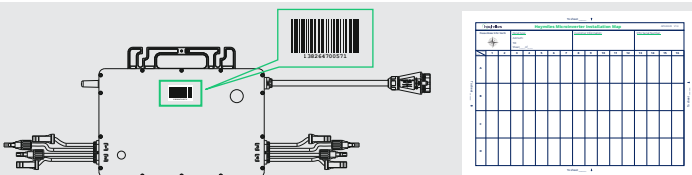
<p>A) Peel the removable serial number label from each microinverter. B) Affix the serial number label to the respective location on the installation map (please refer to the User Manual).</p>	
--	--

Step 5. Connect PV Modules

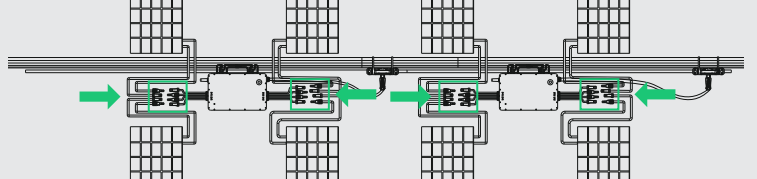
<p>A) Mount the PV modules above the microinverter. B) Connect the PV modules' DC cables to the DC input side of the microinverter.</p>	
---	--

Step 6. Energize the System

- A) Turn on the AC breaker for the branch circuit.
- B) Turn on the main AC breaker for the house. Your system will start to generate power in about two minutes.

Step 7. Set up Monitoring System

Please refer to the DTU User Manual or DTU Quick Installation Guide, and Quick Installation Guide for S-Miles Cloud to install the DTU and set up monitoring system.

Product information is subject to change without notice. (Please download reference manuals at www.hoymiles.com).