



MNE300ROSIE-240P MANUAL

Rosie E-Panel Owner's Manual





MNE300ROSIE-240P MANUAL

Table of Contents

Introduction	3
Safety Instructions	4
Battery Safety	5
How to KILL Your Batteries	7
How An Inverter/Charger Works	8
Wiring Requirements	8
DC Wiring and Over-Current Protection	9
AC Wiring and Over-Current Protection	10
Grounding / Arc Fault / Ground Fault	12
Installation	12
Mounting.....	14
Wiring The Rosie E-Panel	14
Internal Wiring	16
External Wiring.....	17
Charge Controller Wiring	19
How The E-Panel Works	20
Energizing the Rosie & E-Panel	21
Technical Drawings	26
Torque Requirements	28
Warranty	30

This entire manual is printed without color but is available for download—with many of the diagrams available in color—on our website at midnitesolar.com.



MNE300ROSIE-240P MANUAL

INTRODUCTION

The Rosie E-Panel is an AC and DC enclosure offering over-current protection (OCP) and disconnects for AC IN, AC OUT, and to the battery bank. The E-Panel is designed specifically for the MidNite Solar MNROSIE7048 inverter/charger.

Standard Features:

- Terminal blocks to attach optional MidNite Solar Surge Protection Devices
- Styled to match the MNROSIE7048 inverter/charger
- 80VDC, 300A, battery positive circuit breaker
- Listed to UL1741 and CSA 107.01 Standards (Pending)
- 60A AC Bypass circuit breaker assembly
- 60A AC IN and AC OUT circuit breakers
- Optional backplate for mounting
- Ground busbar

Physical Features:

- **E-Panel Dimensions**
 - 13.8" H x 13.94" W x 8.25" D
 - Weight – 17.5 lbs
- **Shipping Dimensions**
 - 20.125" H x 17.75" W x 11.5" D
 - Weight – 22 lbs



Pre-Wired MNROSIE7048RE
inverter/Charger with Classic 250 ...
Includes MNGP2 remote panel, PV
breaker, SPDs, and mounting plate.

The Rosie Inverter and E-Panel are shown with optional accessories. The Classic, SPDs, and mounting plate can be ordered separately.



IMPORTANT SAFETY INSTRUCTIONS SAVE THESE INSTRUCTIONS

THIS MANUAL CONTAINS IMPORTANT INSTRUCTIONS FOR THE MIDNITE SOLAR ROSIE E-PANEL THAT SHALL BE FOLLOWED DURING INSTALLATION AND OPERATION.

If you do not fully understand any of the concepts, terminology, or hazards outlined in these instructions, please refer installation to a qualified dealer, electrician, or installer. These instructions are not meant to be a complete explanation of a renewable energy system. Before using the Rosie and E-Panel, read all instructions and cautionary markings. The installation instructions are for use by qualified personnel only. Do not perform any installation other than that specified in this manual unless you are qualified to do so. Incorrect installation may result in a risk of electric shock, fire, or other safety hazard.

Safety Symbols

The following safety symbols have been placed throughout this manual to indicate dangerous and important safety instructions.

WARNING!

WARNING indicates a hazardous situation which, if not avoided, could result in death or serious injury.

CAUTION!

CAUTION indicates conditions or practices that could result in damage to the unit or other equipment.

INFO: Indicates information that emphasizes or supplements important points of the main text.

SAFETY PRECAUTIONS

- Live power may be present at more than one point since an inverter utilizes both DC (batteries) and AC (utility or generator) power. To reduce risk of electric shock, ensure all DC and AC wiring is disconnected prior to installing or performing maintenance on the



MNE300ROSIE-240P MANUAL

inverter. Turning off the inverter will **NOT** reduce this risk; the inverter must be totally disconnected from all sources.

- System grounding is the responsibility of the system installer and must comply with local and national electrical codes and standards.
- This product is a Type 1 enclosure, designed for indoor/compartment installation only. It must not be exposed to rain, snow, moisture, or liquids of any type.
- Listed or labeled equipment shall be installed and used in accordance with any instructions included in the listing or labeling.
- Over-current protection of the AC & DC wiring must be provided as part of the system installation.
- All electrical work must be performed in accordance with local and national electrical codes.
- Use Class 1 wiring methods for field wiring connections to terminals of a Class 2 circuit.
 - There are no Class 2 circuits in the Rosie E-Panel.
- Use insulated tools to reduce the chance of electrical shock or accidental short circuits.
- Torque all wiring and cable connections to the required torque values.
- Use only copper wires with a minimum temperature rating of 90°C.
- Always verify proper wiring prior to starting the inverter.
- Battery cables should be no less than **#4/0 AWG**.
- The Rosie E-Panel must be properly mounted.

BATTERY SAFETY

- Wear eye protection and avoid touching your eyes and face when working with batteries to keep any fluid/corrosion on the battery from contact with eyes and skin. Have plenty of fresh water and soap nearby and thoroughly wash in case battery acid contacts skin, clothing, or eyes. In the event of exposure to the eyes, flood them for at least 15 minutes with running water and seek immediate medical attention. Baking soda neutralizes lead acid battery electrolyte and vinegar neutralizes spilled NiCad and NiFe battery electrolyte; depending on your battery type, keep a supply on hand near the batteries.
- Read and follow the battery manufacturer's safety precautions before installing the inverter and batteries. Always verify proper polarity and voltage before connecting the batteries to the inverter. Once the batteries are connected to the inverter, ensure the maintenance and charging requirements (i.e., charge voltage and charge rate) provided by the battery manufacturer are followed to extend the life of the batteries and to prevent damage to the batteries while charging.
- The battery bank should be installed in a clean, dry, ventilated environment that is protected from high and low temperatures. If installed in a vehicle/boat, the batteries must be mounted upright (if using liquid batteries) and securely fastened. The location must be fully accessible and protected from exposure to heat producing devices, and away from any fuel tanks.



MNE300ROSIE-240P MANUAL

- Batteries can produce explosive gasses, so install batteries in a well-ventilated area. For compartment or enclosure installations, always vent batteries from the highest point to the outside. Design the battery enclosure to prevent accumulation and concentration of hydrogen gas in pockets at the top of the compartment.
- Remove all jewelry such as rings, watches, bracelets, etc., when installing or performing maintenance on the batteries and inverter. A battery can produce a short-circuit current high enough to weld metal jewelry, causing severe burns.
- Use insulated tools and be very careful when working around batteries, they can produce extremely high currents if short-circuited (e.g., dropping a metal tool across the battery terminal), which could cause a fire or explosion.
- When replacing some of the batteries in a bank, always replace with the **same** model, size, Ah capacity, charging voltages, and type of the old batteries. Types include: (Flooded, Lithium, NiFe, sealed, etc.).
- To prevent a spark at the battery and to reduce the chance of explosion, always connect the cables to the batteries first. Then connect the cables to the inverter.
- Never work alone. Always have someone within the range of your voice or close enough to come to your aid when working around batteries.
- Never use old or untested batteries. Check each battery's label for age, type, and date code to ensure all batteries are identical.
- Proper disposal of batteries is required. Refer to your local codes for disposal requirements.
- Batteries are sensitive to changes in temperature. Install batteries in a stable environment.
- Provide at least one inch of air space between batteries to provide optimum cooling.
- For batteries that require the addition of water, follow these important safety tips:
 - Electrolyte Level – NO exposed plates! Ensure plates are covered in electrolyte and slightly below the bottom “funnel” of the battery fill hole.
 - Add distilled water as needed. Do **NOT** fill to the bottom of the funnel neck before you equalize. The electrolyte will probably spill out.
 - Use the MidNite Solar's MNHYDROMETER to measure the specific gravity. Check with your battery manufacturer for the specific gravity values.
- Use proper lifting techniques when working with batteries.
- Never smoke or allow a spark near batteries.
- Never charge a frozen battery.

WARNING!

A battery can present a risk of electrical shock, burn from high short-circuit current, or fire or explosion from vented gases with flooded lead-acid batteries.

(NOTE - Sealed batteries do not vent.)



MNE300ROSIE-240P MANUAL

STANDARDS

The MidNite Solar MNE300ROSIE-240P is listed to *UL 1741, 3rd Edition - UL Standard for Safety Inverters, Converters, Controllers, and Interconnection System Equipment for Use with Distributed Energy Resources* and to *CSA 22.2, No. 107.1, 4th Edition - Power Conversion Equipment* is pending.

HOW TO KILL YOUR BATTERIES

Batteries are delicate and require proper attention, especially when off-grid. Think of your batteries and solar equipment as a small nuclear power plant, hydro dam, or natural gas-fired power plant. Just like any of those, your system needs DAILY attention to ensure it is performing correctly and safely. We recommend the use of an independent battery monitor/alarm if you have an expensive battery bank. Below is a list of some of the most common ways we have seen people kill their battery bank.

- Using more than three parallel strings and not using common bus bars. With lead-acid batteries, when you use more than three strings, it is very hard to properly charge the middle strings. The only safe way to do this is to wire each string with equal length cables to a common bus bar. Connect inverter cables to the farthest points on the busbars.
- Not watching to verify the Absorb or EQ times are set properly and that the equipment actually charges for that period of time. Some equipment will have settings like “End Amps” that can terminate Absorb early and, if set up wrong, can damage a battery.
- Not using ALL EQUAL LENGTH interconnect cables on each string. It is important that ALL strings be wired EXACTLY the same. Any variance in resistance on one string versus another will cause an imbalance and the batteries will suffer a shortened lifespan.
- Trusting a State of Charge (SOC) meter, which can lose calibration over time and give you false readings. You need to verify specific gravity and or verify the charge voltage is being met. Never fully rely on the SOC %; it is just a good, quick reference.
- Routinely using more than 50% of the capacity of the lead acid battery. Using more than half the battery capacity drastically shortens the batteries life; occasionally is fine, but daily will kill lead acid batteries in months.
- Not leaving ample space between cells for cooling. We recommend at least one inch between the cells for cooling. Ask the battery manufacturer what they recommend.
- Not having enough charge current to properly charge the size of the battery you have. Consult the battery manufacturer for the minimum charge current.
- Using tap water or other liquids instead of distilled water in a flooded battery. The minerals in the tap water will destroy a battery.
- Not verifying the temperature compensation neutral point (typically 25°C) and the milli volts per degree C per cell (typically -5mV).



MNE300ROSIE-240P MANUAL

- Not verifying you are charging to the voltage supplied by the battery manufacturer.
- Not fully charging your lead acid batteries at least once a week.
- Failing to keep all connections clean.

HOW AN INVERTER/CHARGER WORKS

Inverter Mode

When the inverter is properly connected to batteries and turned on, the direct current (DC) from the batteries is transformed into a pure sine wave alternating current (AC). This AC is similar to the voltage provided by your utility and is used to power any electrical appliances (AC loads) connected to the inverter's output.

Standby (Charger) Mode

When an external source of AC power (utility power or generator) is connected and qualified on the inverter's AC input, it operates in Standby mode. In Standby mode, the unit operates as a battery charger to convert the incoming AC power into DC power to recharge the batteries; at the same time, the inverter automatically closes an internal AC transfer relay to pass the incoming AC power directly to the inverter's output to continue powering the connected electrical appliances.

WIRING REQUIREMENTS

- The NEC (*National Electric Code, ANSI/NFPA 70*) for the United States and the CEC (*Canadian Electrical Code, Part 1*) for Canada provide standards for safely wiring residential and commercial installations. The NEC/CEC lists the requirements for wire size, over-current protection, and installation methods.
- Do not mix AC and DC wiring in the same panel unless specifically approved/designed for both AC and DC wiring. Where DC wiring must cross AC or vice-versa, try to make the wires at the crossing point perpendicular (90 degrees) to one another.
- AC and DC wires to and from the inverter must be protected as required by code. This can be done by using jacketed wires or by feeding the wires through conduit or a conduit box. The **MNE300ROSIE-240 E-Panel** satisfies this requirement.
- Always check for existing electrical, plumbing, or other areas of potential damage prior to making cuts in structural surfaces or walls.
- Wiring should meet all local codes and standards and be performed by qualified personnel such as a licensed electrician.
- Both AC and DC over-current protection must be provided as part of the installation.



MNE300ROSIE-240P MANUAL

- Coordination of conductor sizes and over-current protection shall be done in accordance with the *Canadian Electrical Code, Part 1*.
- Use only copper wires with a minimum temperature rating of 90°C.
- The equipment ground is marked with this symbol: 

CAUTION!

The Rosie E-Panel is designed for indoor installation or installation inside a weatherproof enclosure. It must not be exposed to rain and should be installed out of direct sunlight.

WARNING!

Wait **5 minutes** after deenergizing (breakers opened, fuses removed) all sources of DC power (batteries) and AC power (utility or AC generator) to the Rosie inverter before opening the cover and/or touching any circuits.

DC Wiring

- Minimize the number of connections between the Rosie and the battery bank. Exceptions are the DC breaker —required at the battery to protect the DC wiring—in the positive line, and a DC shunt—to allow battery charge state monitoring—in the negative line. Additional connections will contribute to voltage drops, and these extra connection points may loosen during use.
- DC cables should be tied together with wire ties or electrical tape approximately every 6". This helps improve the surge capability and reduces the effects of inductance, which improves the inverter waveform and reduces wear of the inverter's filter capacitors.
- The DC cables/wires must be color coded with colored tape or heat shrink tubing: RED for positive (+); WHITE for negative (-) if solidly grounded or BLACK if using a GFP breaker; and GREEN for DC ground.
- All wiring to the battery terminals should be checked monthly for proper torque/tightness. If you don't have a torque wrench, ensure all DC terminals are tight and cannot move.
- The DC cables must be fine strand, super flexible, such as Cobra cable (or equivalent) and be approved for residential wiring per the NEC (THW for example).
- Do not use the inverter's chassis in place of the battery negative connection for grounding. The inverter requires a reliable return path directly to the battery.
- Use tinned copper 5/16" terminal lug on the Batt+ cable to the 300A breaker. Crimp the lug on, then heat-shrink the union of cable to lug. Batt- to the shunt requires 3/8" lug.



MNE300ROSIE-240P MANUAL

- A readily accessible battery disconnect is required and must be located within sight of the battery system (NEC 480.7).
 - If the batteries are external to the location of the Rosie, then the battery installation must be done in accordance with the storage battery rules of the *Canadian Electrical Code, Part 1*.
- Ensure cables have a smooth bend radius and do not become kinked. Follow existing wire runs where possible.
- Ensure both DC cables pass through the same knockout and conduit to allow the inductive currents to cancel.
- Limit cable length to 6' or less from Rosie E-Panel to battery bank.
- **The battery bank voltage MUST be 48V!**

DC Over-Current Protection (OCP)

- The NEC requires both over-current protection (UL489 standards) and a disconnect switch. If a circuit breaker is used as the over-current protection device, it can also be used as the required DC disconnect.
- The DC over-current protection device must be installed on the positive DC cable and it must be correctly sized according to the size of DC cables being used, which means it is required to open before the cable reaches its maximum current carrying capability.
- The MNE300ROSIE-240 E-Panel satisfies the above NEC DC OCP requirements.

AC Wiring

- The wire sizes recommended in this manual are based on the ampacities given in Table 310.17 (in free air) of the NEC, ANSI/NFPA 70, for 90°C copper wire based on an ambient temperature of 30°C (86°F).
- Always use properly rated circuit breakers. If using an electrical sub-panel, circuit breakers can be moved from the main electrical panel to the sub-panel only if the breakers are also listed to be installed in the sub-panel.
- The AC wiring must be protected from short circuits and overloads by an over-current protection device (UL1077 standards) and have a means to disconnect the AC circuits.
- **DO NOT** connect the inverter's output to an external AC power source. This could cause severe damage to the inverter and is not covered under warranty.
- An AC generator wired into the Rosie E-Panel must have an emergency shutdown device located outside the dwelling at a readily accessible location (NEC 445.18).
- AC loads powered by the inverter will need to be installed into an electrical sub-panel with branch breakers to power the AC loads.
- Use **#6 AWG** (or larger), 600V wire for the AC IN and AC OUT wires.



MNE300ROSIE-240P MANUAL

WARNING!

Do NOT connect the E-Panel's AC OUT to an external AC power source.

WARNING!

In most electrical systems, the neutral-to-ground bond is located in the main utility service entrance panel. Remove any bond downstream from the inverter to prevent multiple bonds. If there is an inverter sub-panel—separate from a main electrical panel—it should have a removable wire that allows the neutral bus to be unbonded from the ground busbar.

AC Ground Fault Circuit Interruption (GFCI)

UL standards require the use of GFCI outlets or breakers on the AC output of an inverter.

WARNING!

RISK OF ELECTRIC SHOCK! Use only ground-fault circuit interrupters [receptacle(s) or circuit breaker(s)] compatible with your inverter/charger.

AC Over-Current Protection (OCP)

- Over-current protection for power-feeder conductors from the inverter shall be within seven inches of the output connections or may be within 40 inches of the output connections if the unprotected insulated conductors are contained throughout their entire distance in a sheath or enclosure such as a conduit/junction box or enclosed panel.
- The full AC continuous pass-thru capacity of the Rosie inverter/charger is limited to 60A. **AC IN to the inverter requires a 60A continuous duty rated breaker**, which corresponds to a minimum cable size of #6 AWG. **AC OUT requires a 60A breaker.**
- The AC over-current protection device must be a circuit breaker or a fuse/disconnect and be properly sized and branch circuit rated for the wire it is protecting and the appliances being powered.
- The **MNE300ROSIE-240** E-Panel satisfies the above NEC AC OCP requirements.

Grounding

- The negative battery conductor should be solidly bonded to the grounding system at only one point in the system. The size for the conductor is determined by the size of the largest phase conductor, per the NEC/CEC.



MNE300ROSIE-240P MANUAL

- The AC neutral and equipment ground should only be bonded in one location for the entire system.

Arc Fault - The NEC requires any PV system DC circuit operating at 80VDC or greater must be protected by an arc fault (AF) circuit interrupter.

Ground Fault - Since 2008 the NEC requires a DC Ground Fault (GF) Protection device on all PV systems to indicate when a GF condition exists.

CAUTION!

The Rosie E-Panel may be used in a positive grounded or negative grounded installation. For a grounded system, bond either Battery Negative to Ground, or bond Battery Positive to Ground (but not both at the same time!!).

Installations should be performed by a licensed or certified electrician. It is the installer's responsibility to determine which safety codes apply.

INSTALLATION

Before installing, read the entire installation section to determine how you are going to install your Rosie and E-Panel. The more thoroughly you plan in the beginning, the better your overall system needs will be met.

Location Considerations

- Locate the Rosie as close to the batteries as possible. Long DC wires tend to lose efficiency and reduce the overall performance of an inverter. However, the unit should not be mounted where it will be exposed to gases produced by the batteries. These gases are corrosive and will damage the inverter; also, if these gases are not ventilated and if allowed to collect, they could ignite and cause an explosion.
- The NEC requires 30" clear on the wall. The Rosie may be located anywhere within this 30". The NEC also requires 36" free and clear of obstructions in front of the charge controller.

The 36" clear area in front of all electrical panels is to provide a space to fall back into in case of electrical shock.

- Do not cover or block the Rosie's ventilation openings or install in an area with limited airflow. The Rosie uses four fans to provide forced air cooling; allow at the minimum an



MNE300ROSIE-240P MANUAL

airspace clearance of 6” at the vents and 3” everywhere else to provide adequate ventilation.

- The area must be free from any risk of condensation, water, or any other liquid that can enter or fall on the inverter. The Rosie is indoor rated and should not be placed outside unless precautions are taken to keep rain and moisture off the system.
- Ensure the Rosie is accessible after it is mounted. The Rosie is programmed and data points monitored via a remotely-mounted MNGP2 (MidNite Graphics Panel). You will need to access the MNGP2 during and after installation.
- The Rosie should be protected from direct sun exposure or equipment that produces extreme heat. The ambient temperature around the Rosie must not exceed 77°F (25°C) to meet power specifications.
- If installed in an enclosure, a fresh air intake opening must be provided directly to the bottom side (intake vents) of the inverter and an exhaust opening on the top side (exhaust vents) of the inverter.
- Keep any flammable/combustible material (e.g., paper, cloth, plastic, etc.) that may be ignited by heat, sparks, or flames at a minimum distance of 2’ away from the inverter.
- Mount at least 2’ from any flammable or combustible fluid or components (i.e., paper, cloth, plastic, etc.) that may be ignited by heat, sparks, or flames.

WARNING!

- Do **NOT** install the Rosie in an area that contains extremely flammable liquids like gasoline or propane.
- The Rosie is for use in non-hazardous locations in accordance with the rules of CSA C22.1, *Canadian Electrical Code, Part I*.

- The Rosie should not be installed in an area that allows dust, fumes, insects, or rodents to enter or block the ventilation openings.
- The Rosie weighs 43.5 pounds and the E-Panel weighs 17.5 pounds. The mounting surface and hardware must be capable of supporting at least twice the weight.
- Plan any conduit runs now. Typical wiring and routing examples:
 - AC IN from Grid or Genny or transfer switch
 - AC OUT to service or sub-panel
 - DC cables to battery bank
 - Battery Temp Sensor
- Mount vertically on a flat, **non-combustible** surface.

Mounting – Rosie and E-Panel with Backplate (Figure 1)

1. It is easier to assemble and wire the units together (Backplate lying flat on a workbench) then attach the assembled system to the wall. The assembled system will be heavy and requires two persons to mount to the wall.
 - a. Wire the Rosie and Rosie E-Panel as detailed on page 16.
2. To mount separately:
 - a. Mark wall, pre-drill pilot holes for the Backplate.
 - b. If not using the Backplate, reference keyhole spacing on page 26.
 - c. Mount Backplate to wall using appropriate hardware.
 - d. Attach Rosie E-Panel to Backplate, secure with 4 mounting bolts provided.
 - e. Install two bolts into top holes on Backplate for the Rosie.
 - f. Align the top keyholes (**Figure 1**) on the back flange of the Rosie to the top two bolts. Before mating the Rosie to the E-Panel ... Carefully insert E-Panel wires into bottom access holes on the Rosie.
 - g. Insert bottom mounting bolts for Rosie.
3. Remove the AC conduit adapter cover from Rosie before mating Rosie to E-panel (**Figure 2**).
4. Torque Backplate mounting bolts to 6 inch-pounds.



Figure 1



Figure 2

CAUTION!

Do **NOT** mount this inverter in a zero-clearance compartment, nor cover or obstruct the ventilation openings—overheating may result.

WIRING THE ROSIE E-PANEL

- Take a moment to study the various connections of the Rosie to the E-Panel as shown in **Figure 3**.
- Reference the overall system wiring diagram on page 24.
- Wire the Rosie to the Rosie E-Panel following the numbered steps below.

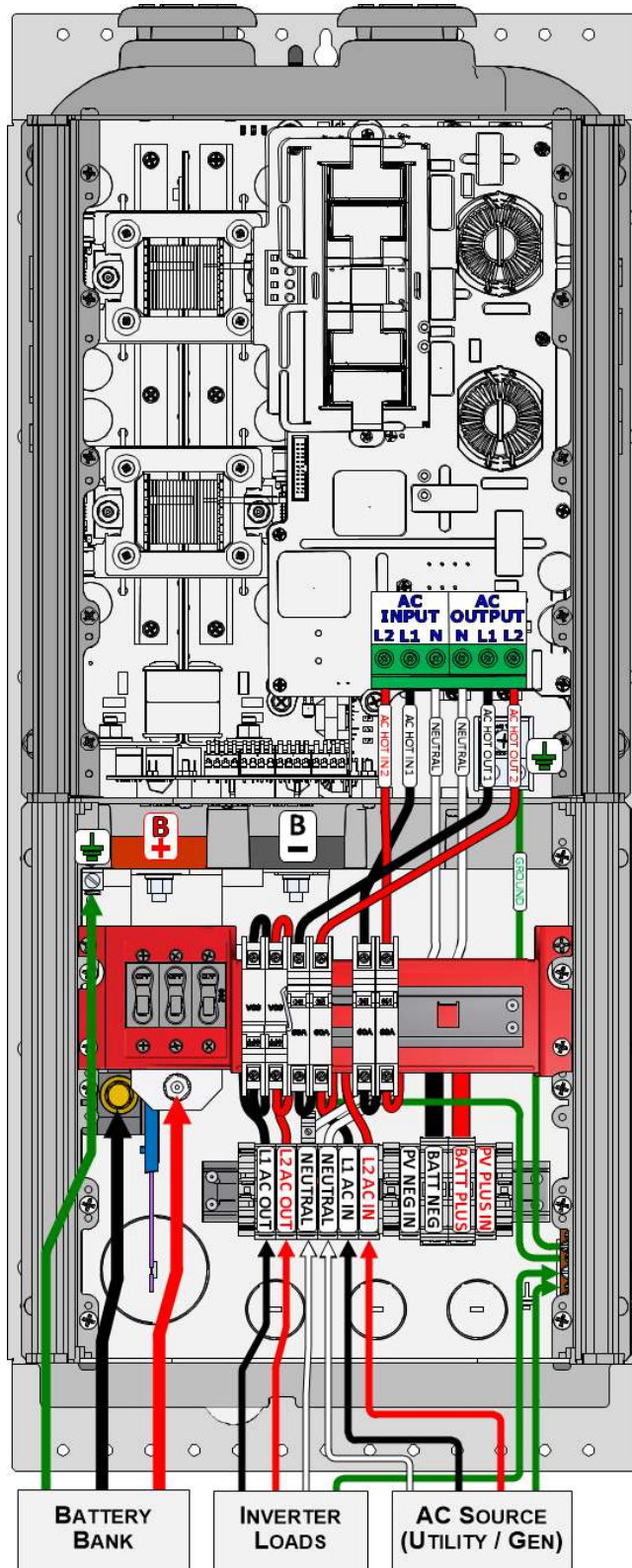

Figure 3



MNE300ROSIE-240P MANUAL

Internal Wiring (Figures 4/5)

Batt Busbars (#1)

1. Ensure all breakers are off (down).
2. Connect the pre-installed Batt+ busbar to the Rosie Batt+ terminal.
3. Connect the pre-installed Batt- busbar to the Rosie Batt- terminal.
4. **Torque.** See page 26 for torque specs.

AC IN Wires (#2A/2B)

1. Ensure all breakers are off (down).
2. Connect the pre-installed AC IN wires to the Rosie AC IN (L1 and L2) terminals.
3. **Torque.**

AC OUT Wires (#3A/3B)

1. Ensure all breakers are off (down).
2. Connect the pre-installed AC OUT wires to the Rosie's AC OUT (L1 and L2) terminals.
3. **Torque.**

AC Neutral Wires (#4A/4B)

1. Ensure all breakers are off (down).
2. Connect the pre-installed AC Neutral wires to the Rosie's AC Neutral terminals.
3. **Torque.**

Ground Wire (#5A/5B)

1. Ensure all breakers are off (down).
2. Connect the pre-installed ground wire to the Rosie's ground terminal.
3. **Torque.**

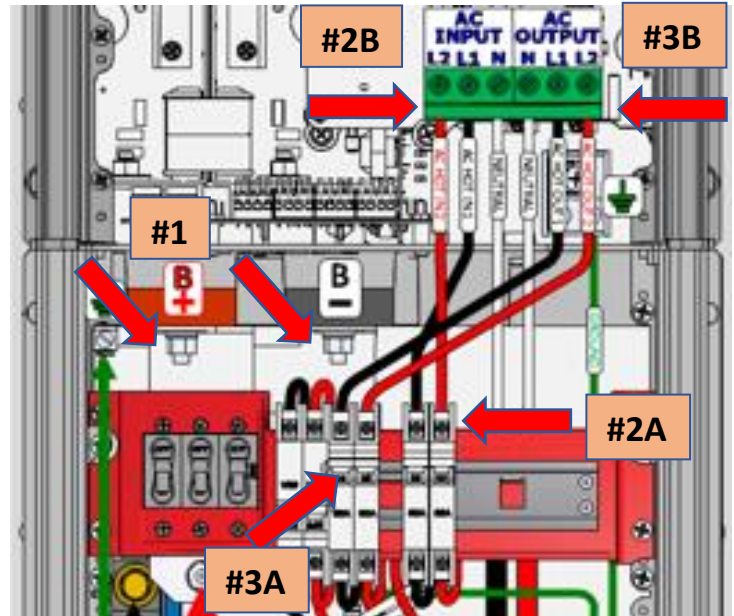

Figure 4

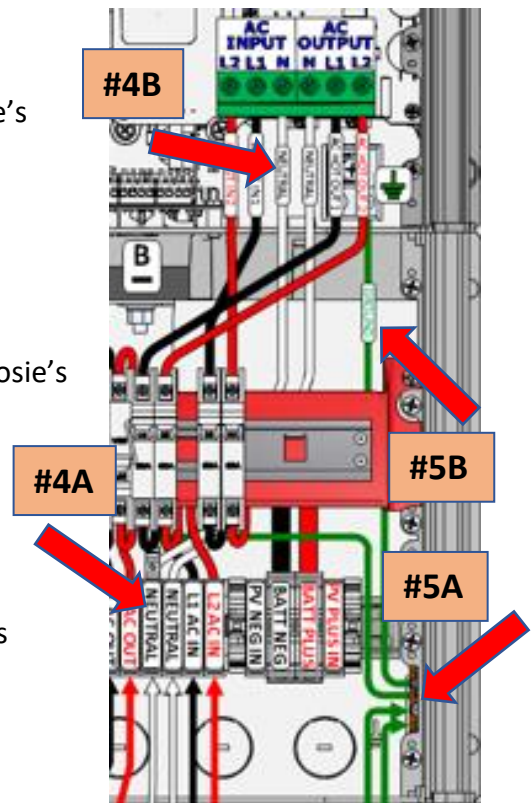

Figure 5

Surge Protection Devices (SPDs) (Figure 6)

1. Install pick-offs at the bottom of the various feed-through terminals (**#6**) to wire in SPDs.
2. **AC OUT** – Connect SPD (MNSPD300AC) red and black wires to AC OUT L1 and L2. Green to ground busbar.
3. **AC IN** – Connect SPD (MNSPD300AC) red and black wires to AC IN L1 and L2. Green to ground busbar.
4. **BATT** – Connect SPD (MNSPD115) red to Batt+, SPD black to Batt-. Green to ground busbar.
5. **PV** – Connect SPD (MNSPD300DC or MNSPD600) red to PV+, SPD black to PV-. Green to ground busbar.
6. **Torque.**

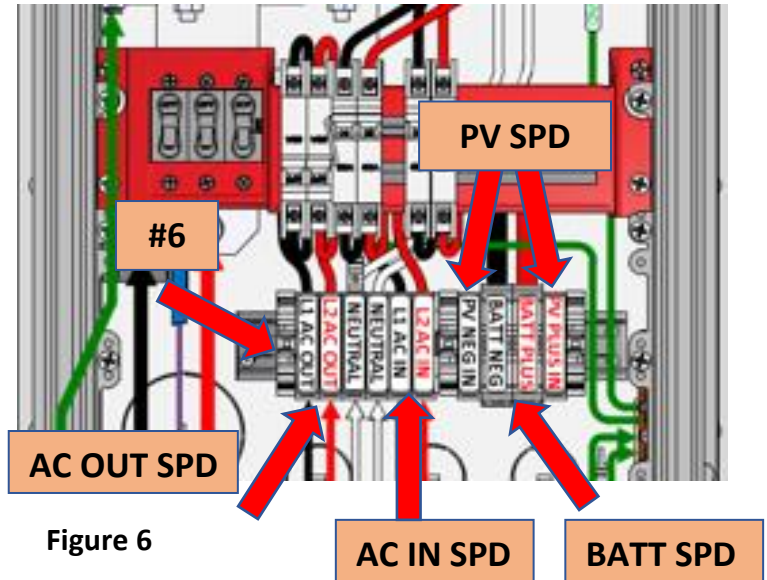

Figure 6

External Wiring (Figures 7/8)

Batt Cables (#7A/7B)

1. Ensure all breakers are off (down).
2. Connect **#4/0 AWG** Batt- cable to battery bank then to E-Panel Batt- terminal (shunt) (**#7A**). **Shunt requires 3/8" lugs.**
3. Connect the **#4/0 AWG** Batt+ cable to battery bank then to E-Panel Batt+ breaker (**#7B**).
4. **Torque.**

AC OUT Wiring (#8)

1. Ensure all breakers are off.
2. Connect two **#6 AWG** wires (L1 & L2) between E-Panel AC OUT terminals and AC electrical sub-panel.
3. **Torque.**

AC IN Wiring (#9)

1. Ensure all breakers are off.

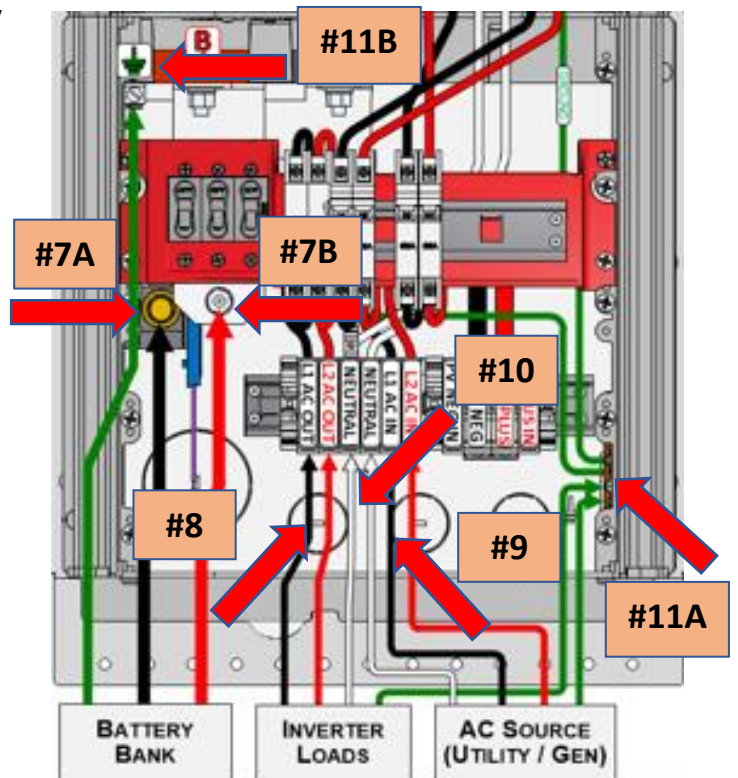

Figure 7



MNE300ROSIE-240P MANUAL

2. Connect two #6 AWG wires (L1 & L2) between E-Panel AC IN terminals and AC grid or generator source.
3. **Torque.**

WARNING!

Verify correct polarity with a multimeter **BEFORE** connecting the battery cables to the Rosie. The Rosie will trip the battery breaker if wired reverse polarity.

AC Neutral Wiring (#10)

1. Ensure all breakers are off.
2. Connect two #6 AWG Neutral wires between:
 - a. Rosie E-Panel AC Neutral terminal and AC grid or generator source.
 - b. Rosie E-Panel AC Neutral terminal and AC electrical sub-panel.
3. **Torque.**

WARNING!

Do **NOT** connect the E-Panel's AC OUT to an external AC power source unless used in an AC-Coupled PV System.

CAUTION!

Only **ONE** Neutral-to-ground bond can exist in this AC system wiring. Pick a spot: 1) At the AC source; 2) In the Rosie E-Panel; 3) At the critical load panel (sub-panel).

Ground Wiring (#11A/11B)

1. Ensure all breakers are off.
2. Connect two ground wires (Equipment Grounding Conductors) between:
 - a. Rosie E-Panel Ground busbar (#11A) and AC (IN) grid or generator source.
 - b. Rosie E-Panel Ground busbar (#11A) and AC (OUT) electrical sub-panel.
3. Connect DC equipment grounding conductor between the Rosie DC equipment ground terminal (#11B) and the Ground busbar (#11A). Installer to supply this ground wire.
4. **Torque.**

Gauge of ground wires is determined by how the overall ground system is constructed. See **page 22** of the Rosie Owner's Manual for more grounding information.

Whiz Bang Jr (WBJr) Wiring (#12)

1. Connect WBJr purple wire to the External Sensor board in the Rosie inverter/charger, terminal marked "WBJR."
2. See **Rosie Manual**, page 26.

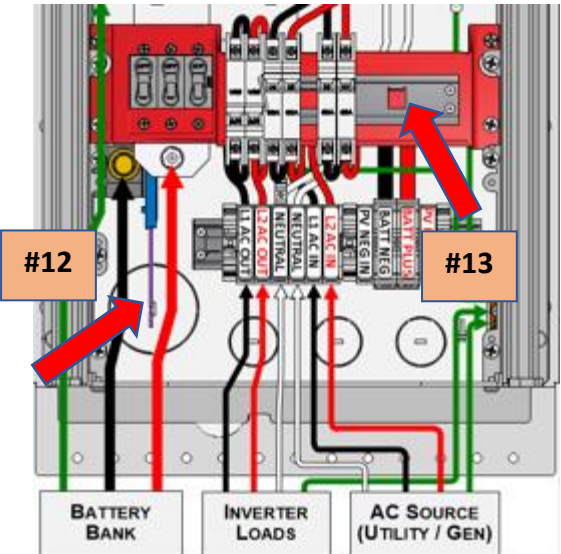

Figure 8

Charge Controller Wiring (Figures 9/10)

PV/Batt Breakers (#13)

1. If using a charge controller in your system, install PV and Battery breakers on the DIN rail (#13).

PV Wires (#14/17/18)

1. Ensure all breakers are off (down).
2. Connect PV+ wire from the PV array to the PV+ terminal (#14).
3. Connect PV+ wire from PV+ terminal (#14) to the PV IN breaker (#17).
4. Connect PV+ wire from the PV IN breaker (#17) to charge controller's PV+ terminal (#18).
5. Connect PV- wire from the PV array to the PV- terminal (#14).
6. Connect PV- wire from the PV- terminal (#14) to the charge controller's PV- terminal (#18).
5. Torque.

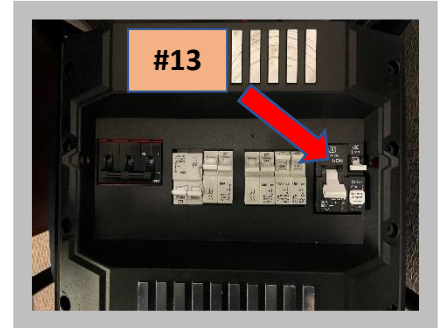

Figure 9

Batt Wires (#15/16/18)

1. Ensure all breakers are off (down).
2. Connect charge controller's Batt+ wire to Rosie's 300A DC Batt breaker (#15A) then to charge controller's Batt+ breaker ("MPPT OUT") (#15B).
3. Connect Batt+ wire from MPPT OUT breaker (#15B) to charge controller's Batt+ terminal (#18).
4. Connect charge controller's Batt- wire to Rosie's Batt- busbar (#16) then to charge controller's Batt- terminal (#18).
6. Torque.

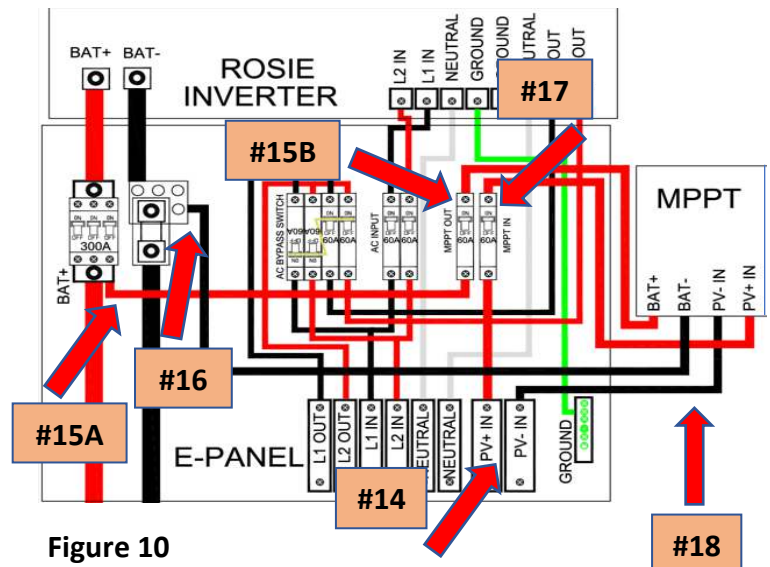

Figure 10

CAUTION!

Recheck all torques after an hour. Conduct a pull test. Copper is a relatively soft metal and will continue to move under inadequate clamping pressure.

HOW THE E-PANEL WORKS (Figures 11/12/13)

NOTE: Yellow arrows show AC path. To minimize clutter, only L1 is marked; L2 flows the same as L1.

AC IN (Figure 11)

With AC IN wired from the AC Source (#1), and the AC IN breaker (#2) on, AC IN flows from (#1) through the AC IN breaker (#2) to the Rosie AC IN terminal (#3).

The Rosie uses the AC IN to charge the batteries (as needed) and supplies AC OUT to the AC electrical panel (sub-panel). The “AC OUT” though is from the grid or genny, not from the Rosie – the AC OUT passes through the Rosie.

AC OUT (Figure 12)

With the Bypass breaker (#2) in the Invert position (slide up; Bypass breaker is OFF, AC OUT breaker is ON), when the Rosie is inverting (using battery power to make AC), AC flows from the Rosie (#1) through the AC OUT breaker (#2, right-side breaker) to the AC OUT terminal (#3), then to the AC electrical sub-panel.

Bypass ON (Figure 13)

With AC IN wired from the AC Source (#1), when the Bypass breaker (#2) is in the Bypass position (slider down; Bypass breaker is ON, AC OUT breaker is OFF), AC IN flows from (#1 - AC IN) through (#2 - Bypass breaker) to (#3 - AC OUT).

The AC IN breaker (#4) may remain in the ON position because when the Bypass breakers (#2) are turned ON, doing so turns off the AC OUT breaker (#2, right-side breaker), thus no AC OUT from the Rosie. The utility of the bypass breaker is to ensure that two AC Sources are never present at the AC OUT busbar at the same time.

There are several reasons why you may need to use the bypass breaker:

- The Rosie has failed.

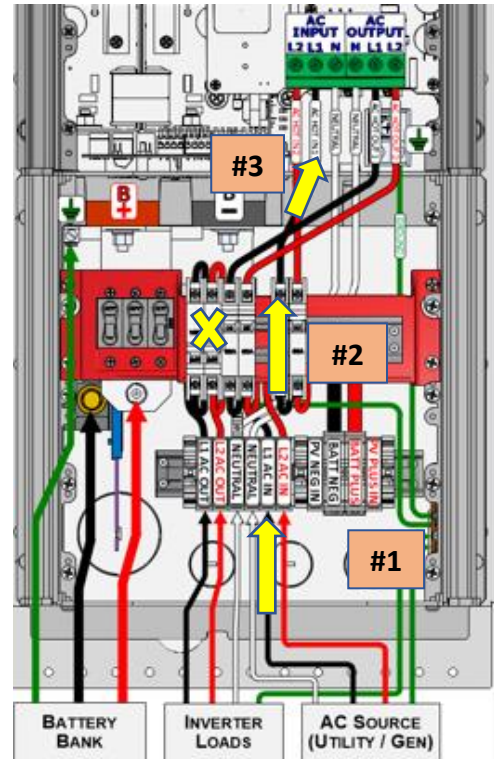

Figure 11

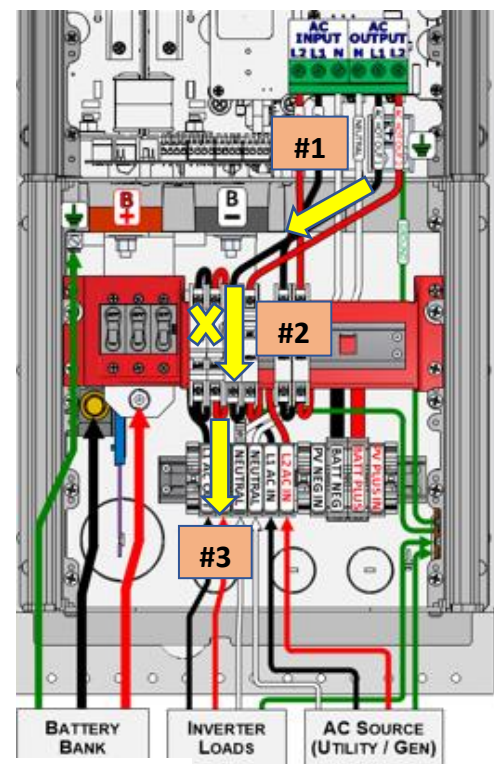

Figure 12



MNE300ROSIE-240P MANUAL

- Turn on the generator, move bypass breakers to the Bypass position (move Bypass slider down), now the generator is passing directly from AC IN to AC OUT.
- You want to run AC loads (via grid or genny) without using Rosie to charge the batteries.
- Troubleshooting.

ENERGIZING THE ROSIE & E-PANEL

Before using the Rosie, the wiring installation must be tested. Follow the steps below:

Step #1 – Turn OFF all breakers

Step #2 - Battery

- **Voltmeter** – Measure for battery bank voltage (40-65VDC) between the E-Panel Battery breaker (at bottom of breaker) and the battery bank negative terminal (at the shunt is OK).
 - Battery bank voltage present?
 - **Yes** – Good (40-65VDC)
 - **No** – Check DC wiring to the battery. Check batteries.
 - Correct polarity shown on the voltmeter?
 - **Yes** – Good
 - **No** – Reverse the DC wiring.
- Turn ON (close) the E-Panel Battery breaker.
- **Voltmeter** – Measure for battery bank voltage between the Rosie’s Batt+ and Batt- terminals.
 - Battery bank voltage present?
 - **Yes** – Good. The Rosie will automatically turn on now.
 - **No** – Check DC wiring or battery breaker.

Step #3 – Program Rosie (See Rosie Owner’s Manual)

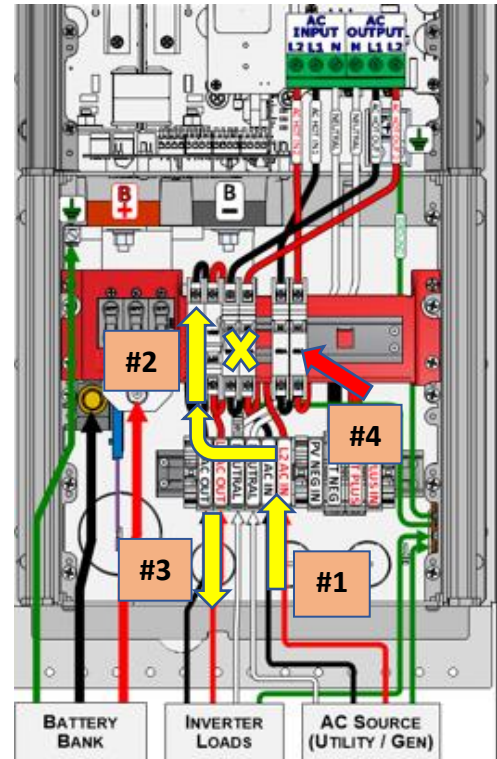

Figure 13



MNE300ROSIE-240P MANUAL

Step #4 – AC OUT (Shown in Figure 12)

- Ensure AC Bypass breakers are OFF (Bypass slider is up, in the INVERT position).
- **Voltmeter** – Measure for 120VAC between Rosie’s AC L1 OUT and AC Neutral terminal.
 - 120VAC present?
 - **Yes** – Good
 - **No** – Check Rosie programming.
- **Voltmeter** – Measure for 120VAC between Rosie’s AC L2 OUT and AC Neutral terminal.
 - 120VAC present?
 - **Yes** – Good
 - **No** – Check Rosie programming.
- **Voltmeter** – Measure for 240VAC between Rosie’s AC L1 OUT and AC L2 OUT terminals.
 - 240VAC present?
 - **Yes** – Good
 - **No** – Check Rosie programming.
- **Voltmeter** – Measure for 120VAC and 240VAC at the AC electrical sub-panel.
 - 120VAC and 240VAC present?
 - **Yes** – Good
 - **No** – Check AC wiring. Check AC OUT breaker.

Step #5 – AC IN (Shown in Figure 11)

- Ensure AC Bypass breakers are OFF (Bypass slider is up, in the INVERT position).
- Turn ON (close) the AC IN breaker.
- Turn ON AC IN source (grid or genny).
- **Voltmeter** – Measure for 120VAC between Rosie’s AC L1 IN and AC Neutral terminal.
 - 120VAC present?
 - **Yes** – Good
 - **No** – Check AC source, connections, or AC IN breaker.
- **Voltmeter** – Measure for 120VAC between Rosie’s AC L2 IN and AC Neutral terminal.
 - 120VAC present?
 - **Yes** – Good
 - **No** – Check AC source, connections, or AC IN breaker.
- **Voltmeter** – Measure for 240VAC between Rosie’s AC L1 IN and AC L2 IN terminals.
 - 240VAC present?
 - **Yes** – Good



MNE300ROSIE-240P MANUAL

- **No** – Check AC source or connections.
- Repeat same measurements for **Step #4 – AC OUT**. Checking for AC OUT while AC IN is active.
- Check that the batts are being charged.
 - Yes – Good
 - No – Check Rosie programming.

Step #6 – AC Bypass ON (Shown in Figure 13)

- Turn ON (close) AC Bypass breakers (Bypass slider is down, in the BYPASS position).
- Turn ON AC IN source (grid or genny).
- **Voltmeter** – Measure for 120VAC between E-Panel AC L1 OUT and AC Neutral terminal.
 - 120VAC present?
 - **Yes** – Good
 - **No** – Check AC source, connections, or Bypass breakers.
- **Voltmeter** – Measure for 120VAC between E-Panel AC L2 OUT and AC Neutral terminal.
 - 120VAC present?
 - **Yes** – Good
 - **No** – Check AC source, connections, or Bypass breakers.
- **Voltmeter** – Measure for 240VAC between E-Panel AC L1 OUT and AC L2 OUT terminals.
 - 240VAC present?
 - **Yes** – Good
 - **No** – Check AC source, connections, or Bypass breakers.

If the above steps check good, the Rosie and E-Panel are ready for operation.



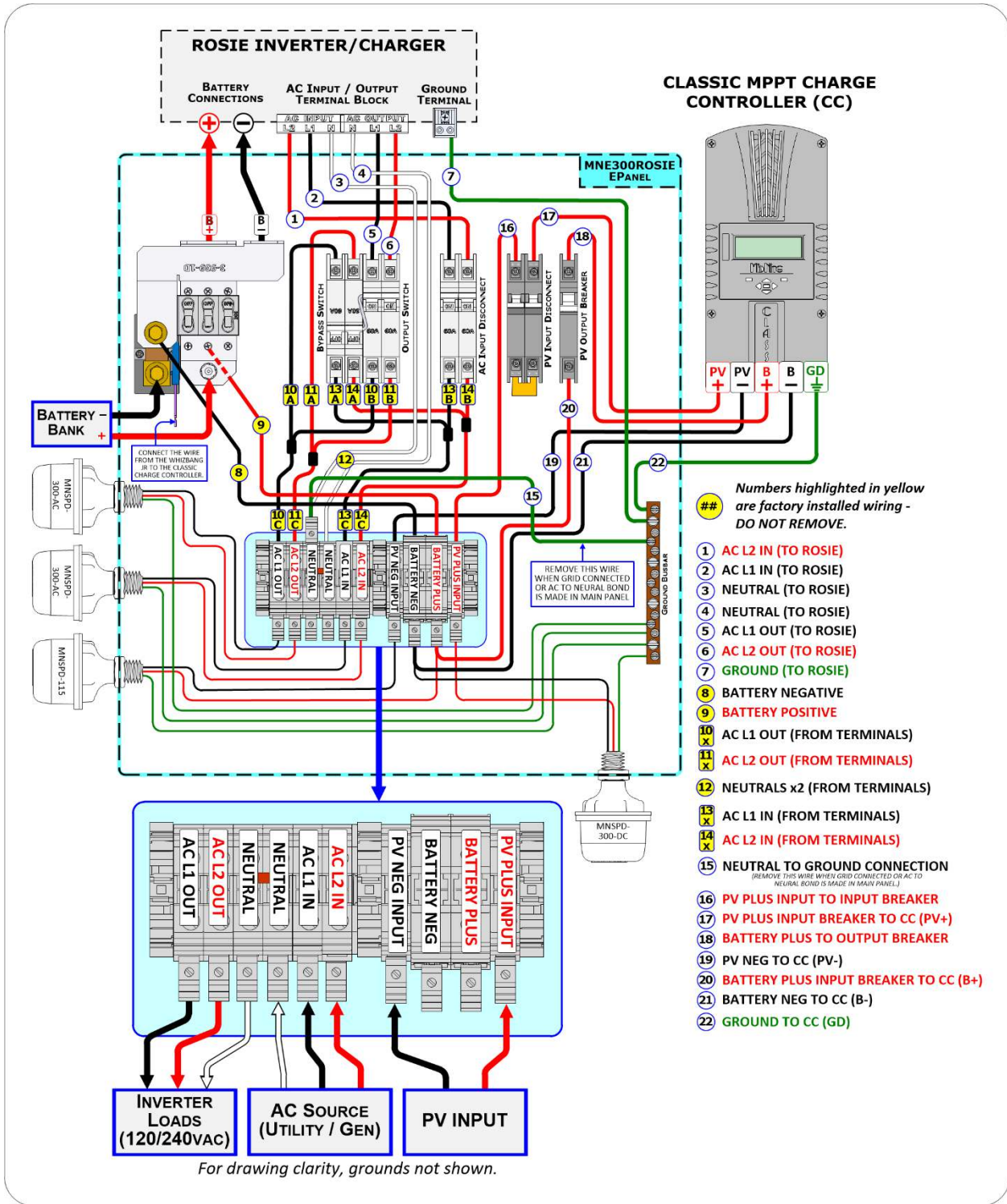



MNE300ROSIE-240P MANUAL

STACKED ROSIE SYSTEM

14KW, 240VAC Rosie System – Primary & Follower

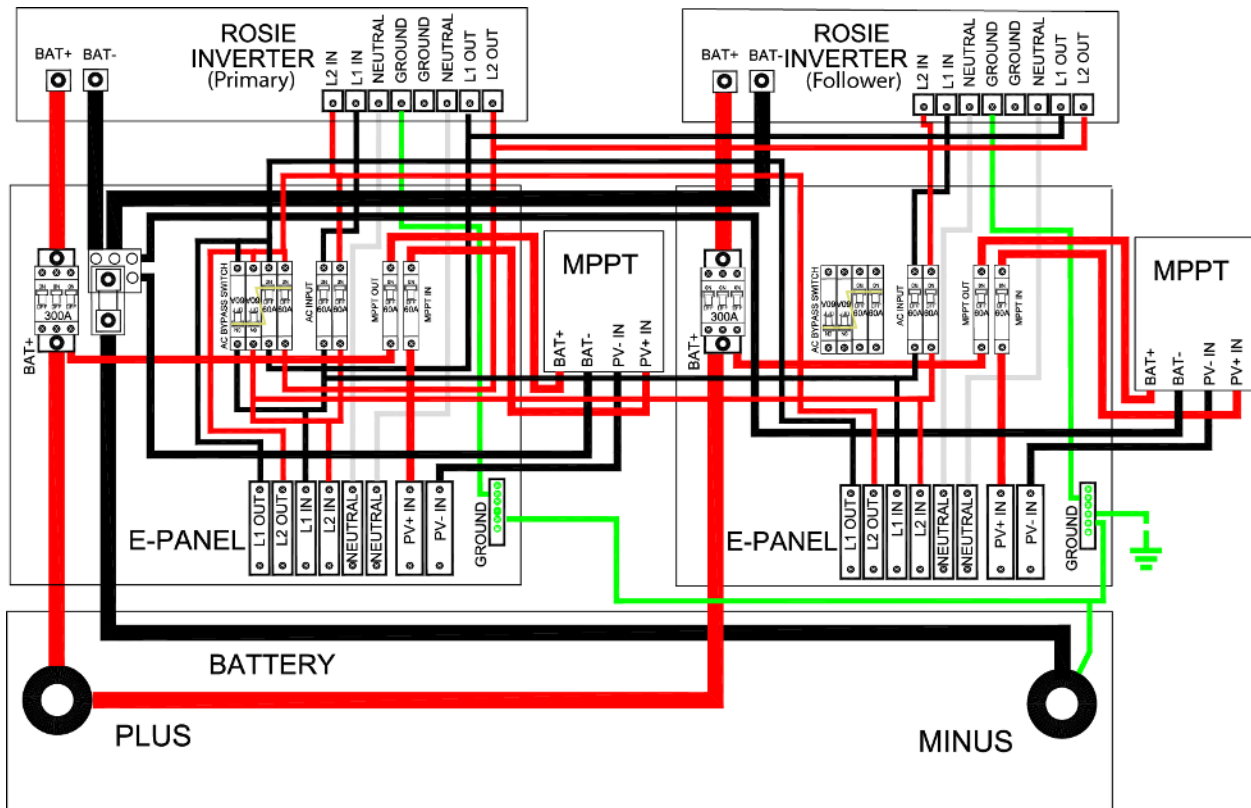

The Rosie Inverter/Charger may be stacked in a dual system configuration to achieve 14KW at 240VAC using the Rosie **MNE300ROSIE-240P** E-Panel as Primary and the **MNE300ROSIE-240F** as Follower. The Follower E-Panel offers AC and DC OCP for the second Rosie. AC wires and DC cables from the Follower E-Panel are routed to the Primary E-Panel. E-Panels offer numerous advantages, such as ease of installation, NEC compliance, and full over-current protection.

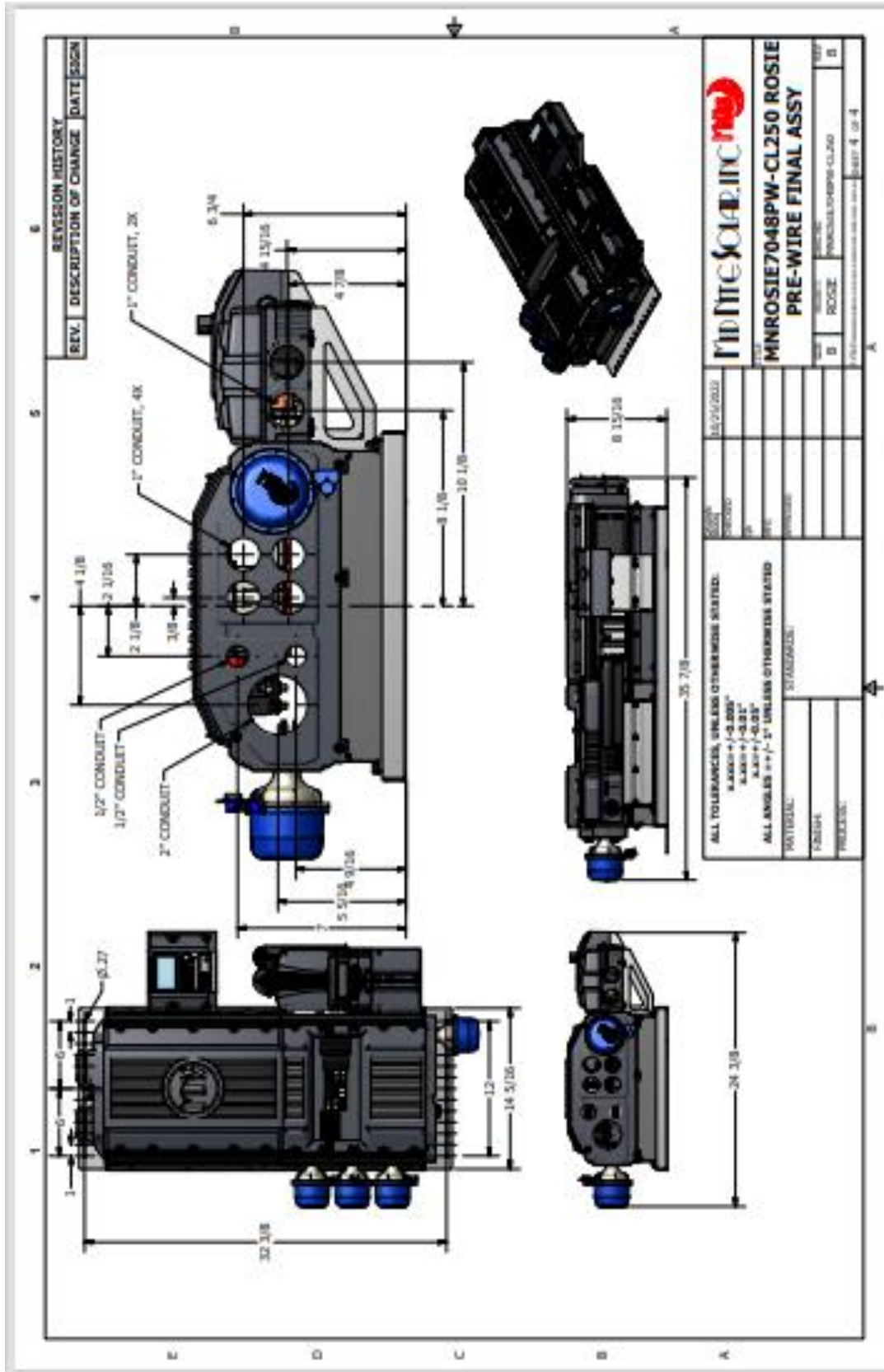



MNE300ROSIE-240P MANUAL

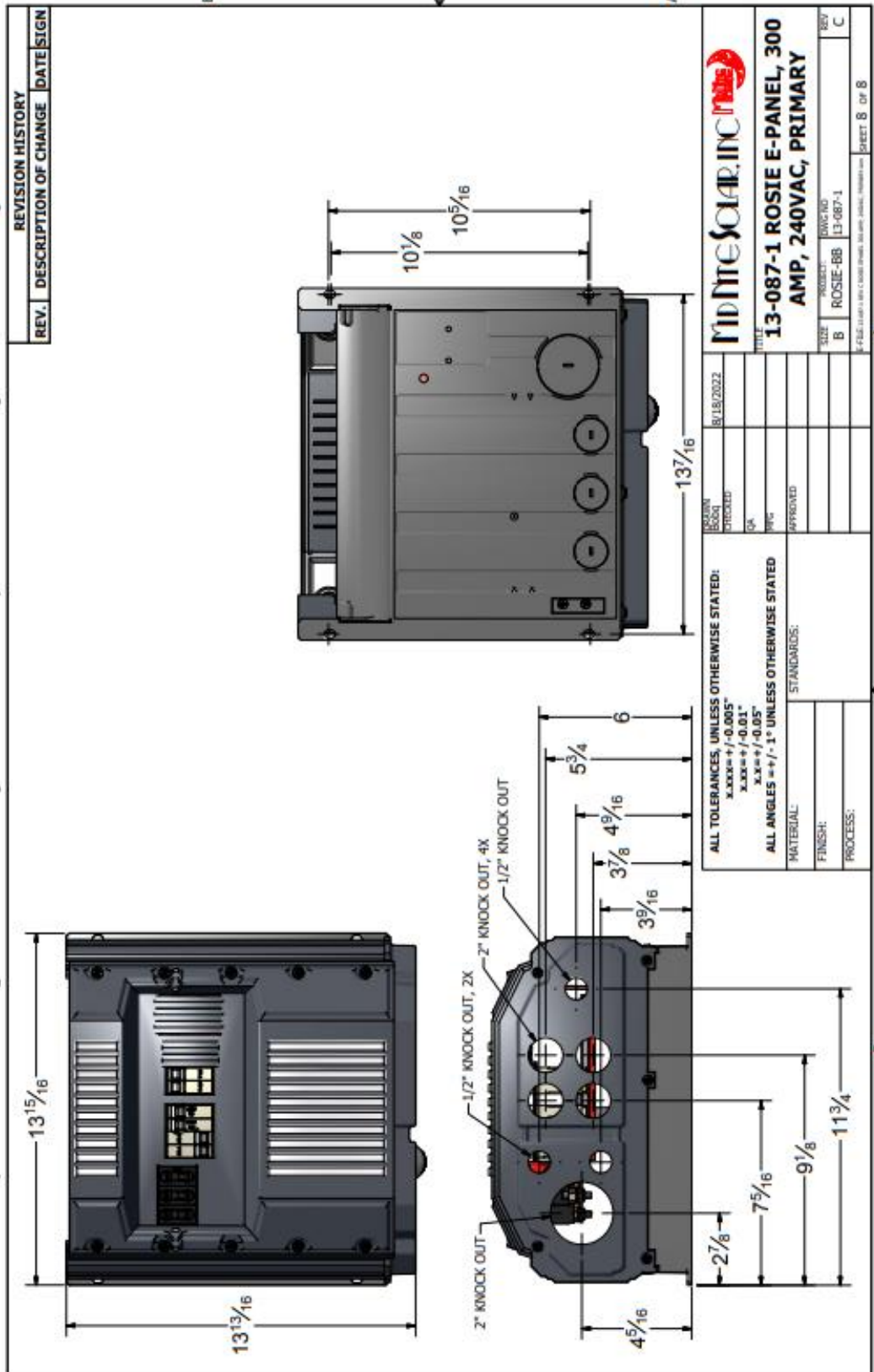

Torque Requirements

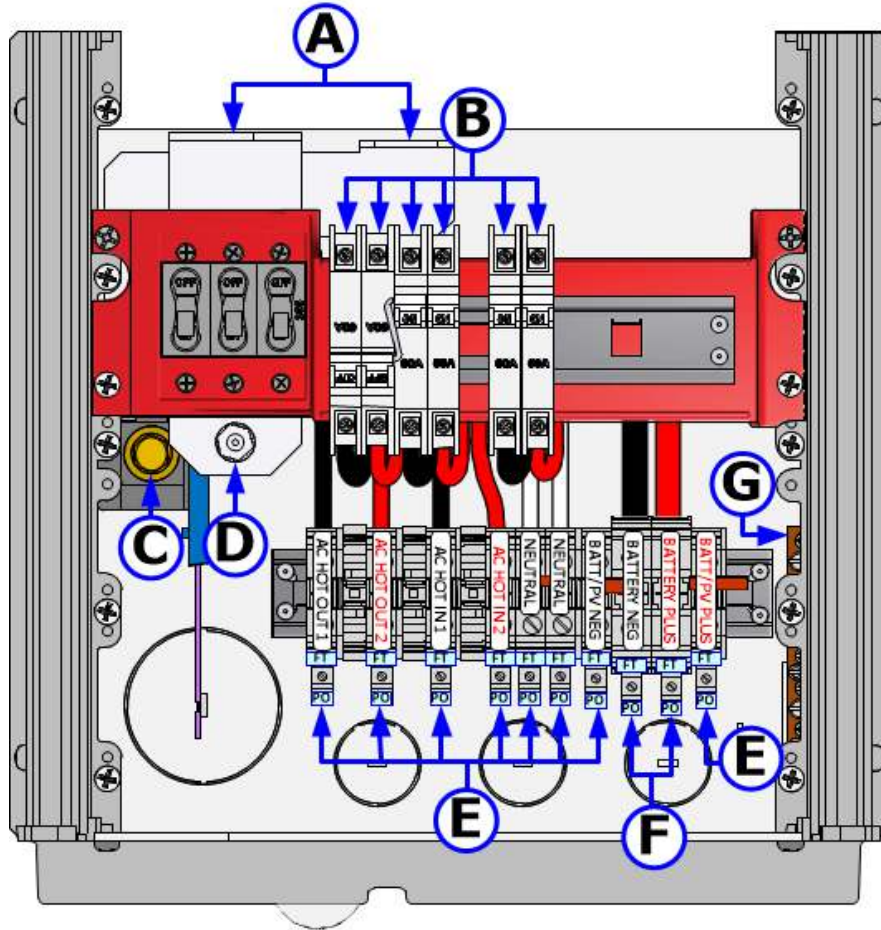

MNE300ROSIE-240 Tightning Torque Requirements		
LABEL	DESCRIPTION	TORQUE
A	Battery Input Busbar (+) to Rosie	10 - 12 ft-lbs
	Battery Input Busbar (-) to Rosie	(13.6 - 16.3 N-m)
B	AC Bypass & Input Terminals to Rosie (Pozi driv #2 Combi head screws)	2 AWG (35 in-lbs / 3.9 N-m) 4 AWG (28 in-lbs / 3.2 N-m) 18 - 8 AWG (20 in-lbs / 2.3 N-m)
C	Battery Negative Input / DC Shunt (3/8"-16 bolt with 9/16" hex head)	16 - 20 ft-lbs (13.6 - 16.3 N-m)
D	Battery Positive Input / 300A Breaker (8 X 1.25mm KEP Nut)	24 ft-lbs (32 N-m)
E	Feed-Thru (FT) Terminals: AC Input/Output (16- 4AWG)	22 - 27 in-lbs (2.5 - 3 N-m)
	Pick-Off (PO) Terminals: AC Input/Output (26- 10 AWG)	5.3 - 7.1 in-lbs (0.6 - 0.8 N-m)
F	Feed-Thru (FT) Terminals: AC Input/Output (14 - 1/0 AWG)	28 - 33 in-lbs (3.2 - 3.7 N-m)
	Pick-Off (PO) Terminals: AC Input/Output (26 - 10 AWG)	5.3 - 7.1 in-lbs (0.6 - 0.8 N-m)
G	Ground Busbar (small screws)	20 in-lbs (2.3 N-m)
	Ground Busbar (large screws)	45 in-lbs (5.1 N-m)

CAUTION: BONDING BETWEEN CONDUIT CONNECTION IS NOT AUTOMATIC AND MUST BE PROVIDED AS PART OF THE INSTALLATION.
USE ONLY WITH COPPER CONDUCTORS RATED 90°C MIN.

ATTENTION: L'INTERCONNEXION DES CONDUITS NE SUFFIT PAS POUR ASSURER LA MISE À LA MASSE, ELLE DOIT FAIRE PARTIE INTÉGRANTE DE L'INSTALLATION.
UTILISER UNIQUEMENT AVEC CONDUCTEURS DE CUIVRE NOMINALE MINIMALE DE 90° C.

MNE300ROSIE-240P
 MNE300ROSIE-240F
 MNE300ROSIE-120F

OPERATING TEMPERATURE RANGE -40°F TO 60°C
 TORQUE BATTERY BREAKER TO: 24W/6 25 IN-LBS, 4 AWG 28 IN-LBS, 18-6 AWG 30 IN-LBS
 TORQUE AC BREAKER TO 28 IN-LBS
 AFTER ONE HOUR RE-TORQUE ALL BREAKERS.
 MAX INPUT INTERRUPT 3,000 AAC, 5,000 ADC
 AC BREAKERS - RINGAC SERIES 5-80 AMP
 DC BREAKER RMEDC-200300-60PNP, MINIPV SERIES
 INPUT AC VOLTAGE RANGE: 80 TO 140 VAC PER LEG.
 BATTERY DC INPUT / OUTPUT RANGE: 40 TO 60 VDC
 USE 4/0 OR LARGER BATTERY CABLE.

CAUTION: RISK OF ELECTRIC SHOCK - MORE THAN ONE DISCONNECT SWITCH MAY BE REQUIRED TO DE-ENERGIZE THE EQUIPMENT BEFORE SERVICING.
AVERTISSEMENT: CET ÉQUIPEMENT RÉFÈRE PLUSIEURS CIRCUITS SOUS TENSION, VOIR LE SCHEMA.
CAUTION: BONDING BETWEEN CONDUIT CONNECTION IS NOT AUTOMATIC AND MUST BE PROVIDED AS PART OF THE INSTALLATION.
ATTENTION: L'INTERCONNEXION DES CONDUITS NE SUFFIT PAS POUR ASSURER LA MISE À LA MASSE, ELLE DOIT FAIRE PARTIE INTÉGRANTE DE L'INSTALLATION.
USE ONLY WITH COPPER CONDUCTORS RATED 90°C MIN.
UTILISER UNIQUEMENT AVEC CONDUCTEURS DE CUIVRE NOMINALE MINIMALE DE 90° C.

Conforms to: IEC 61841-1:2014
 Power Converters/Inverters and Power Converter/Inverter Systems for Land Vehicles and Marine Crafts
 #22822

19115 62nd Ave NE
 Arlington, Wa
 98223 USA
 MANUFACTURE DATE
 Q1 Q2 Q3 Q4
 23 24 25 26 27
www.midnitesolar.com

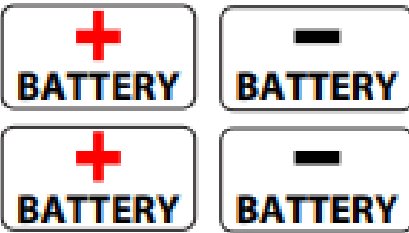

TORQUE (P/N) BREAKERS TO 28 IN-LBS (2.5NM) TORQUE ENERTRONIC TERMINAL BLOCKS TOOL A - 0.8NM

GROUND

TORQUE LANCE SCREWS TO 45 IN-LBS (5.1 NM), TORQUE SMALL SCREWS TO 20-30 IN-LBS (2.5NM) USE 1/0 WIRE

TORQUE BATTERY TERMINALS TO 21 LBF (28.5 NM)

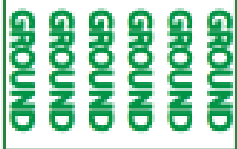
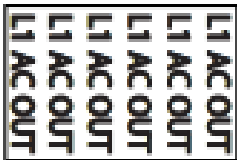
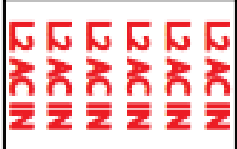

GROUND LUG TORQUE
 4-6 AWG 35 IN-LBS (4 Nm)
 8 AWG 25 IN-LBS (2.8 Nm)
 10-14 AWG 20 IN-LBS (2.3 Nm)

10-562-1 REV B



MNE300ROSIE-240P MANUAL

MIDNITE SOLAR INC. LIMITED WARRANTY

MidNite Solar Power electronics, sheet metal enclosures and accessories

MidNite Solar Inc. warrants to the original customer that its products shall be free from defects in materials and workmanship. This warranty will be valid for a period of five (5) years.

MidNite Solar will not warranty third party inverter components used in MidNite's pre-wired systems. Those components are warranted by the original manufacturer.

At its option, MidNite Solar will repair or replace at no charge any MidNite product that proves to be defective within such warranty period. This warranty shall not apply if the MidNite Solar product has been damaged by unreasonable use, accident, negligence, service, or modification by anyone other than MidNite Solar, or by any other causes unrelated to materials and workmanship. The original consumer purchaser must retain original purchase receipt for proof of purchase as a condition precedent to warranty coverage. To receive in-warranty service, the defective product must be received no later than two (2) weeks after the end of the warranty period. The product must be accompanied by proof of purchase and Return Authorization (RA) number issued by MidNite Solar. For an RMA number contact MidNite Solar Inc., (360) 403-7207. Purchasers must prepay all delivery costs or shipping charges to return any defective MidNite Solar product under this warranty policy. Except for the warranty that the products are made in accordance with, the specifications therefore supplied or agreed to by customer:

MIDNITE SOLAR MAKES NO WARRANTY EXPRESSED OR IMPLIED, AND ANY IMPLIED WARRANTY OF MERCHANTABILITY OR FITNESS FOR A PARTICULAR PURPOSE WHICH EXCEEDS THE FOREGOING WARRANTY IS HEREBY DISCLAIMED BY MIDNITE SOLAR AND EXCLUDED FROM ANY AGREEMENT MADE BY ACCEPTANCE OF ANY ORDER PURSUANT TO THIS QUOTATION. MIDNITE SOLAR WILL NOT BE LIABLE FOR ANY CONSEQUENTIAL DAMAGES, LOSS OR EXPENSE ARISING IN CONNECTION WITH THE USE OF OR THE INABILITY TO USE ITS GOODS FOR ANY PURPOSE WHATSOEVER. MIDNITE SOLAR'S MAXIMUM LIABILITY SHALL NOT IN ANY CASE EXCEED THE CONTRACT PRICE FOR THE GOODS CLAIMED TO BE DEFECTIVE OR UNSUITABLE.

Products will be considered accepted by customer unless written notice to the contrary is given to MidNite Solar within ten (10) days of such delivery to customer. MIDNITE SOLAR is not responsible for loss or damage to products owned by customer and located on MIDNITE SOLAR'S premises caused by fire or other casualties beyond MIDNITE SOLAR'S control. This warranty is in lieu of all other warranties expressed or implied.

MIDNITE SOLAR INC.



MNE300ROSIE-240P MANUAL

NOTICE OF COPYRIGHT

MidNite Solar's MNE300ROSIE-240P E-Panel User's Manual.
Copyright © 2023 All rights reserved.

MidNite Solar, Inc. reserves the right to revise this document and to periodically make changes to the content hereof without obligation or organization of such revisions or changes unless required to do so by prior arrangement.

DISCLAIMER

Unless specifically agreed to in writing, MidNite Solar Inc.: (a) Makes no warranty as to the accuracy, sufficiency, or suitability of any technical or other information provided in its manuals or other documentation; (b) Assumes no responsibility or liability for loss or damage whether direct, indirect, consequential, or incidental, which might arise out of use of such information. The use of any such information will be entirely at the user's risk.

CONTACT

360.403.7207

customerservice@midnitesolar.com

www.midnitesolar.com

