

Titan Lite 2L - Installation Manual

Fixed Ground Mount



Install Solar Faster

www.fast-rack.ca



Section	Pg
1.0 Using this Manual	1
2.0 Safety	2
3.0 Scope of Delivery	3
4.0 Base Connections	4
4.1 Base Spacing	5
4.2 Angle Selection	6
5.0 Preparing to Install the Frames	7
5.1 Installing the Elevation Bar	8
5.2 Installing the Back Bar	9
5.3 Installing the Cross Brace	10
6.0 Preparing to Install the Rails	11
6.1 Installing the Rails	12
7.0 Preparing to Install the PV Modules	13
7.1 Installing the PV Modules (72 Cell)	14
7.2 Installing the PV Modules (60 Cell)	15
8.0 PV Module Bonding	16
9.0 Installing the HL Brace	17
10.0 Inspection & Maintenance	18
11.0 Design Limitations	19



Introduction

This manual is an illustrated guide on how to install a Titan Lite 2L system. It is meant to cover each individual step of the assembly process. Throughout the guide, references will be called to the parts list in order to assist in easily identifying the items required for a specific section. The guide is broken into several sections, each covering the milestone assembly steps, with sub assembly steps in-between where necessary. Each assembly step will include an illustrated list of hardware to be used during that assembly process. Where specified, some assembly sections include a preparation process. It is necessary to follow these preparations in order for the installation to continue smoothly, with no need for back tracking.

Throughout the guide there are reference markings for warnings, and recommendations, identified by these symbols:



Be sure to look for and read these markings. They will provide information such as guidelines to prevent damage to equipment, safety measures to prevent serious injury or bodily harm, and advice on how to make the assembly quicker.

Liability

The installer and/or contractor or developer of each project shall be responsible and liable for safe and proper installation of each system, and also to initiate, maintain and supervise all safety programs and precautions for each project and project site, and to provide all required protection to prevent damage, injury, loss or death to any or all persons, property and work present or located on the project site.

ChargeSolar™ does not install any portion of its mounting systems and therefore will not have, and hereby specifically disclaims, any duty or responsibility for safe and proper installation of any mounting system or jobsite safety as to any jobsite where installation of any of its mounting systems occurs. Please follow the drawings and instructions, and report any issues or discrepancies to ChargeSolar™.

Compliance

The Fast-Rack photovoltaic bonding components meet the requirements of CSA TIL No. A-40 and are individually certified to recognized to UL Standard 2703 and ETL listed to UL Standard 467.



Personal Safety

Prior to starting the installation, it is important to identify all potential hazards and implement a safety plan denoting how to deal with these hazards.

Examples of some potential personal hazards which may be encountered during an installation are:

- Fall Hazards – Ensure compliance with OSHA regulations for working at height. Use fall protection, or fall prevention equipment and practices as necessary.
- Electrical Hazards – Observe the location of overhead and underground conductors/electrical equipment. When possible disconnect/lockout circuits in the work area.
- Lifting Hazards – Use proper lifting techniques to prevent work place injuries when moving components on the ground and lifting between the ground and array location.
- Environmental Hazards – Rain, snow, wind, sun and heat. All of these have the potential to injure personnel and property if not properly prepared for.

Once the hazards specific to the installation have been identified, it is critical to devise a plan should a workplace accident occur. Some things to have prepared and discussed prior to start of work are:

- Location of nearest hospital, emergency phone number
- Trained and certified on-site first-aid attendant and location of first-aid kit
- Devise method for extracting injured personnel
- Communication and awareness of potential hazards
- Trained and certified fall protection training for all personnel working at height

ChargeSolar[™] offers regular training courses for Fall Protection Awareness, while Occupational First Aid courses can be found in most municipalities often through local fire departments.

Site Safety

Evaluate and identify potential safety hazards and injuries that could occur on the job site. This includes specific work situations and understanding the potential injuries from the identified hazards. Maintaining safety policies and general jobsite safety practices goes a long way to ensuring a smooth and safe install.

Ground-mounted installations often involve the use of heavy equipment for moving materials, grading or clearing land and installing foundations. Ensure machines are being used properly by trained professionals and all workers are familiar with the safety risks of working on a site that uses heavy equipment.

To mitigate the risk of injury and theft on the jobsite, proper fencing, signage and policies should be used. Ensure all construction practices are being implemented as per the Ministry of Labour. Workers, supervisors and employers are all responsible for safety.



Components

ID	PART	CODE	QTY
1	Foot	TL-FOOT	4
2	Elevation Bar	TL-ELEV-BAR	2
3	Back Bar	TL-BB	2
4	Cross Brace	TL-CROSS-BRACE	1
5	Pivot Bracket	TL-PIVOT	2
6	Typhoon Rail	TYP-HDRAIL-19.5	4

Hardware

ID	SIZE	TYPE	QTY
A	0.500 x 1.250	Hex Bolt	24
B	0.500	Flat Washer	48
C	0.500	Hex Nut	24
D	0.312 x 1.000	Hex Bolt	32
E	0.312	Flat Washer	32
F	0.312	Nylock Nut	32
G	0.312	Typhoon Clip C	32
H	0.312	Bonding Washer	12
I	0.250 x 0.750	Hex Bolt	48
J	0.250	Flat Washer	48
K	0.250	Nylock Nut	48
L	0.250	Rail Clip A	48

Tools

- 3/4" Open end wrench, socket & ratchet
- 1/2" Open end wrench, socket & ratchet
- Torque wrench

! Upon receipt of goods, make sure to check all packaging to ensure delivery of all parts required.

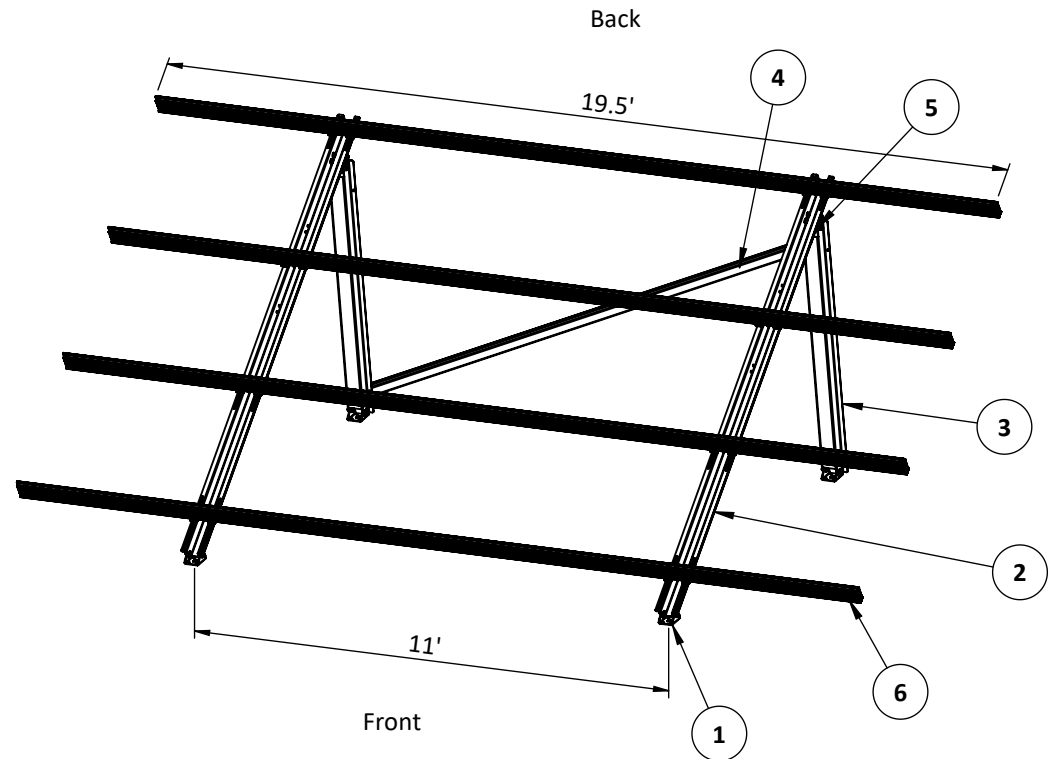



The two most common concrete foundations are the Pier Base and Pad Base. They both use 3/4" anchor bolts that are embedded in the concrete.

The racking may also be installed to a wood or metal frame using 3/8" lag screws or bolts. Alternative foundation options may be used if approved by an engineer.

Spacing of the anchor bolts must be followed to ensure the racking fits together properly.

⚠ Consult with an engineer before proceeding with the base installation

⚠ Anchor bolts must be 3/4". Embedment and concrete dimensions to be confirmed by an engineer.

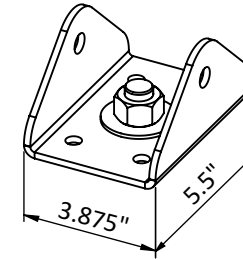
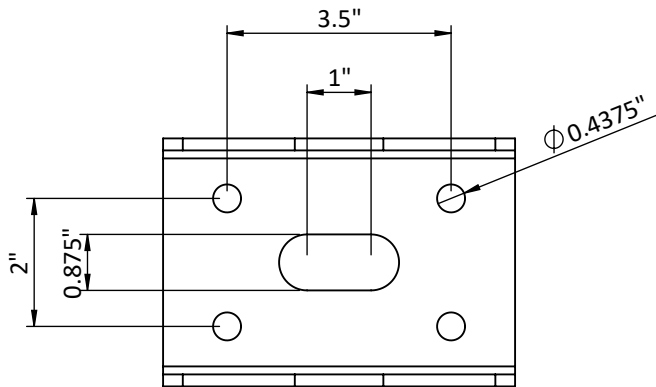

Bolted Connection

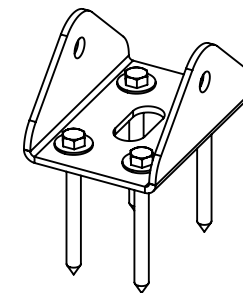

Lag Screw Connection



4.1 Base Spacing

The rack spacing shown is generic and based on a typical system. It is important to verify array dimensions and determine the allowable shadow angle. This will minimize the footprint of the system while limiting shading between rows.

- i** Other spacing may be used. Ensure there is enough space between the racks.
- i** Take into account uneven terrain to limit shading. On some sites it may be recommended to increase the spacing.

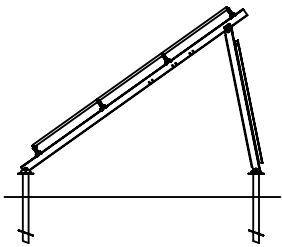

Piles

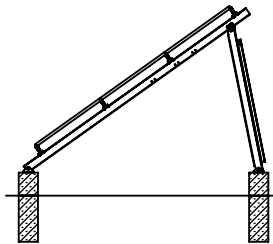

Piers

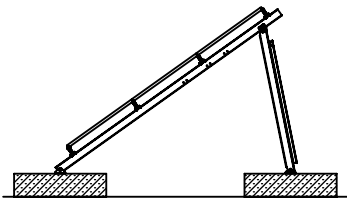

Pads

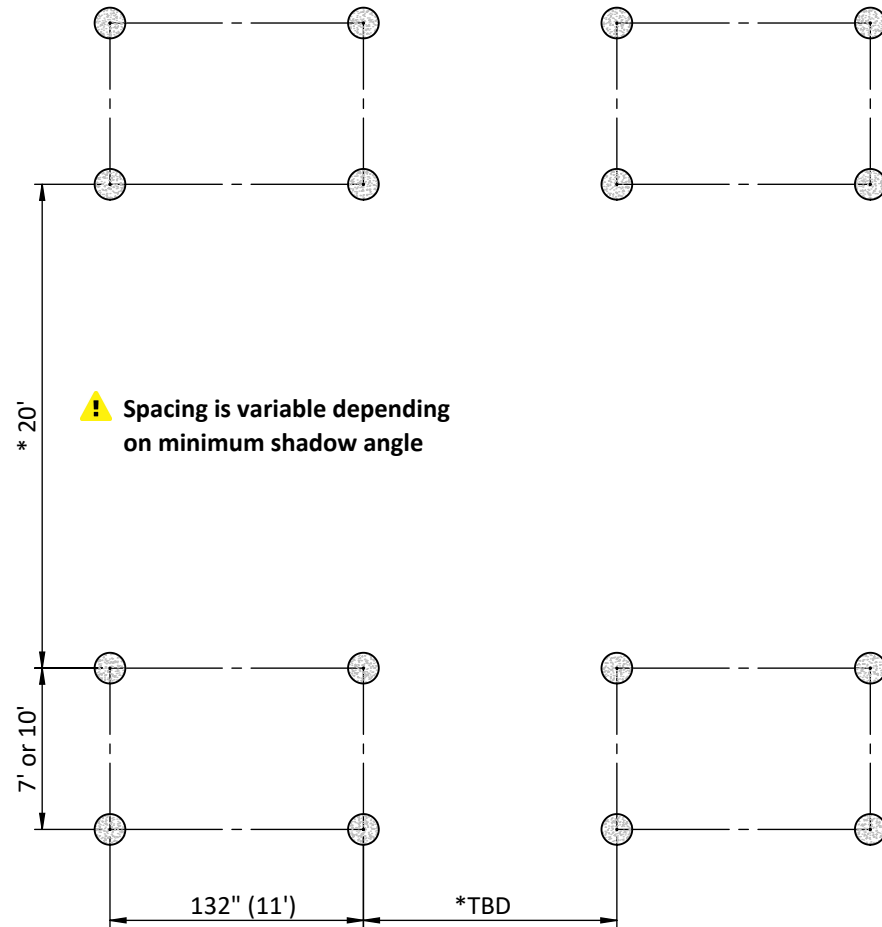

! Spacing is variable depending on minimum shadow angle

! Spacing is variable depending on PV module length and desired space between arrays.



4.2 Angle Selection

The Titan Lite can be installed at angles ranging from 35° to 55°. Use the following chart to properly space and position your system to the desired angle.

The foundations are to be spaced at the 7' or 10' marks as required.

ANGLE	POSITION	SPACING
35	P1	10'
40	P2	10'
45	P2	7'
50	P3	7'
55	P4	7'

 **Tilt angle must be selected before constructing the foundations.**

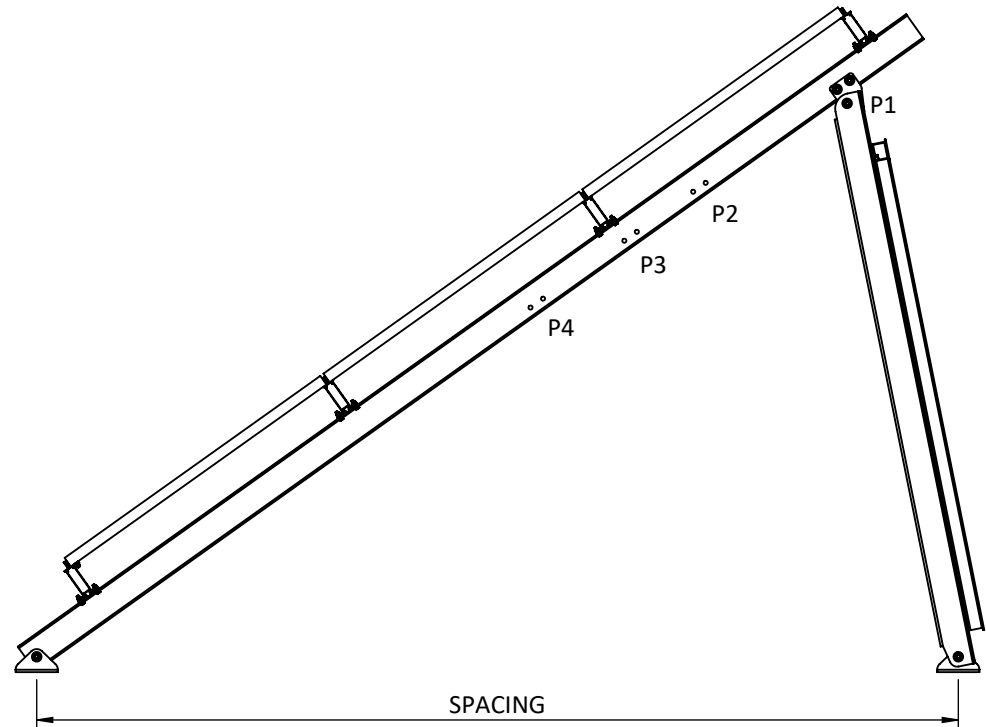



5.0 Preparing to Install the Frames

Before installing the frames, ensure the Feet are secured and properly aligned. All feet for the system should be installed prior to beginning with the frame assembly.

Frames must be fully assembled with Cross Braces to avoid putting unnecessary stress on the Foot connections. Avoid leaving them standing unsupported.

- i** Refer to markings to correctly orient the Elevation Bar and Back Bar.

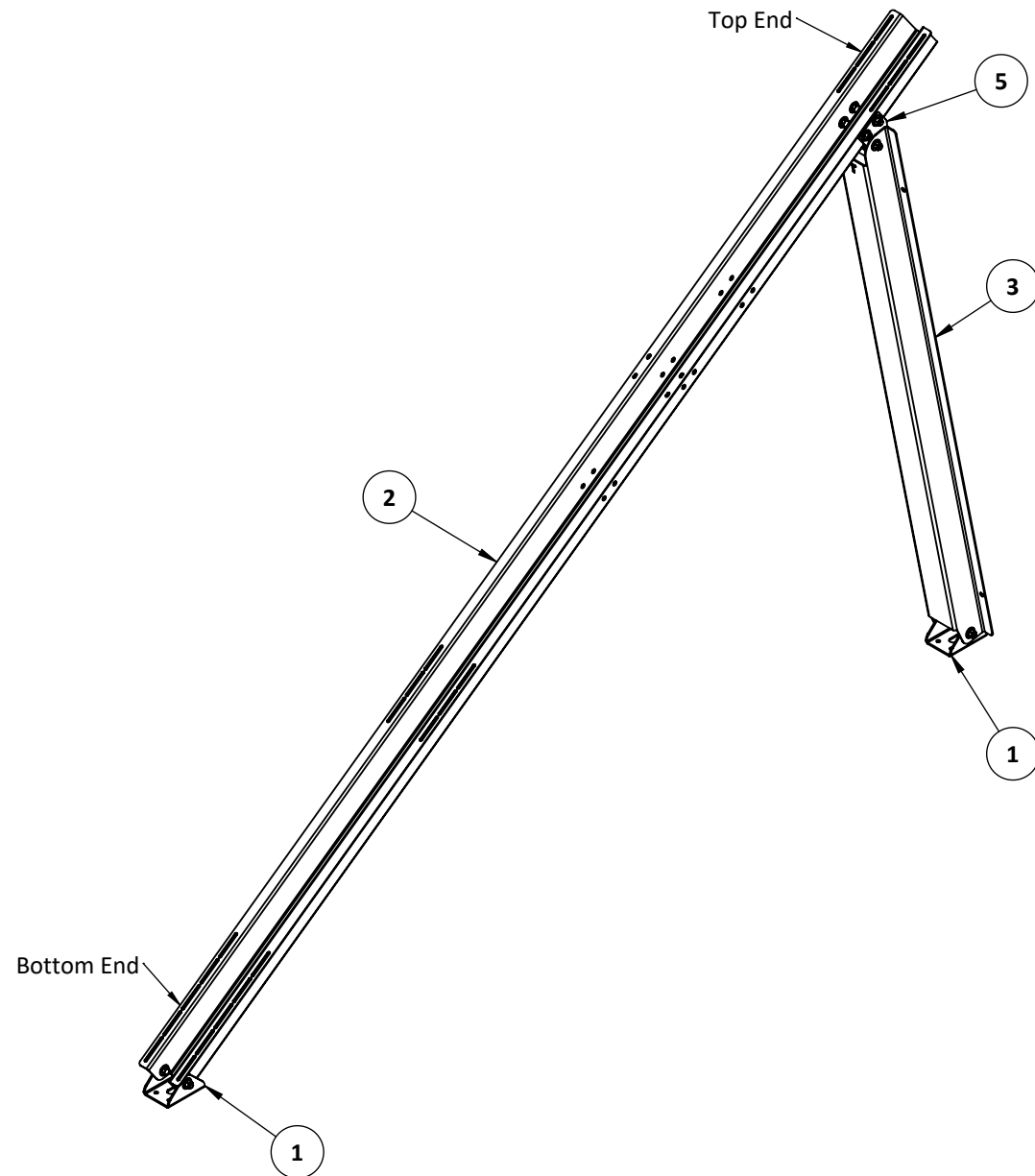



5.1 Installing the Elevation Bar

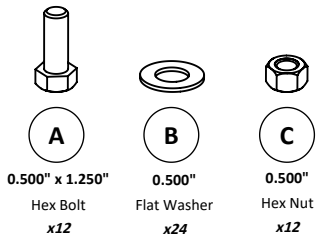

Connect the bottom end of the Elevation Bar to the front Foot. Bolt through both sides as shown. Leave these bolts loose so the angle of the Elevation Bar can be set.

Fasten the Pivot Bracket to the top end of the Elevation Bar. Install the through bolts and fully tighten. Ensure the Pivot Bracket opening is facing outwards as shown.

- i** The end of the Elevation Bar with 3 slots is the top.
- i** Install the Foot bolts with the nut on the outside to allow easier access for tools.

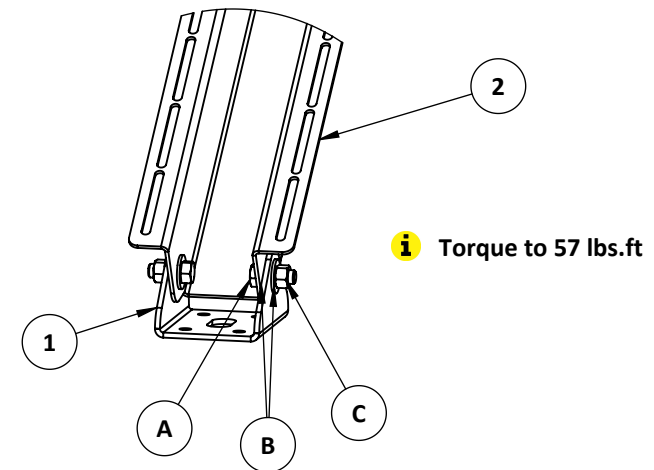
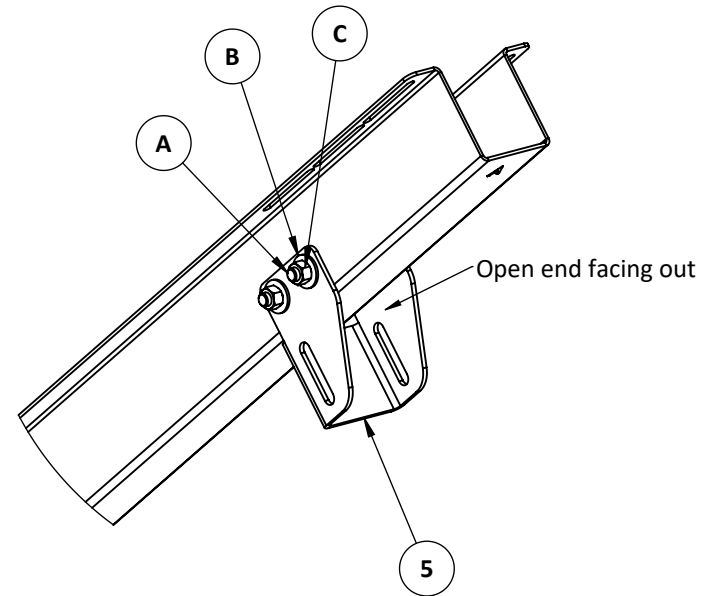



5.2 Installing the Back Bar



A

0.500" x 1.250"

Hex Bolt
x8



B

0.500"

Flat Washer
x16



C

0.500"

Hex Nut
x8

Connect the bottom end of the Back Bar to the back Foot. Bolt through both sides as shown. Leave these bolts loose so the angle of the Elevation Bar can be set.

Fasten the top end of the Back Bar to the Pivot Bracket. Allow the slot to bottom out. This can be adjusted as required to keep adjacent frames level and aligned.

i The end of the Back Bar with the 'T' marking is the top.

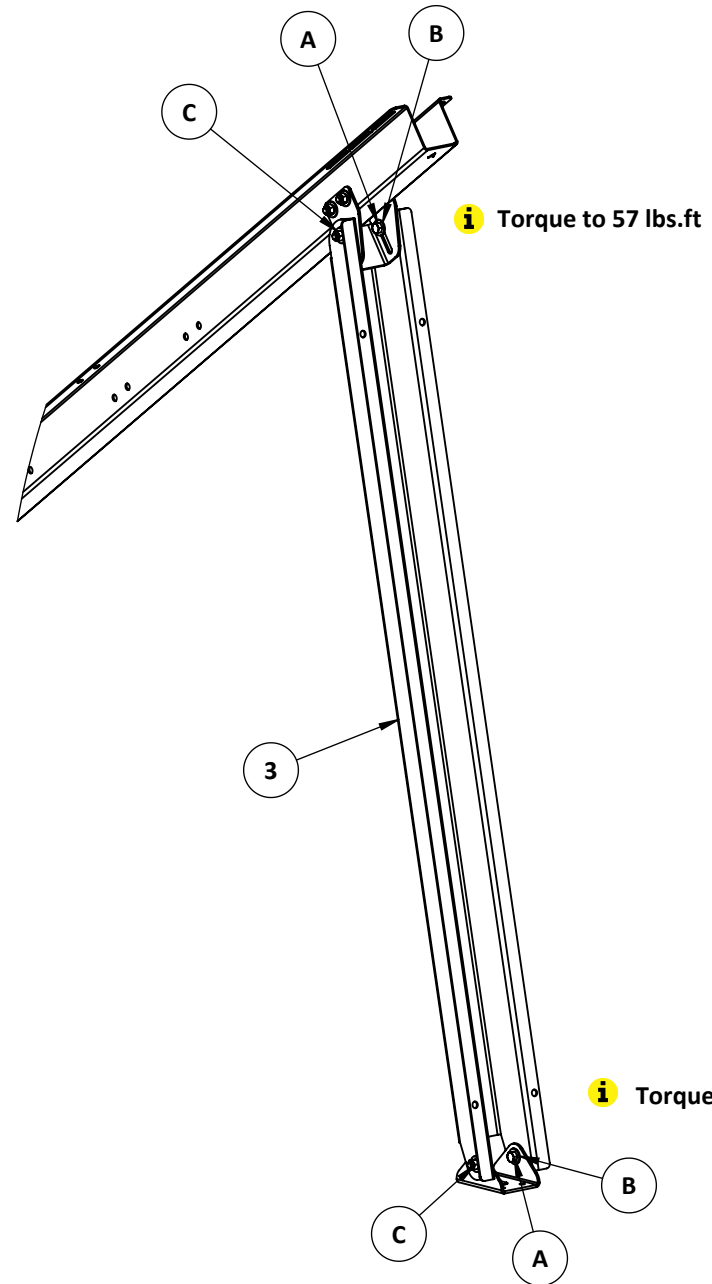



5.3 Installing the Cross Brace

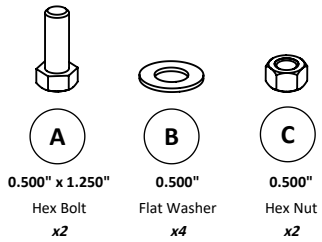

The Cross Brace bolts to the Back Bars. It connects from the top end of one side, to the bottom end of the other side. Attach at the mounting holes as shown using the provided hardware.

Install the end with the hole first. Swing the Cross Brace until the slotted end aligns with the mounting hole on the adjacent Back Bar.

Once the Cross Brace is installed, check the system for alignment. Make adjustments as required to level the system by moving along the Pivot Bracket slot. Once the frames are level, torque all hardware.

i Torque to 57 lbs.ft

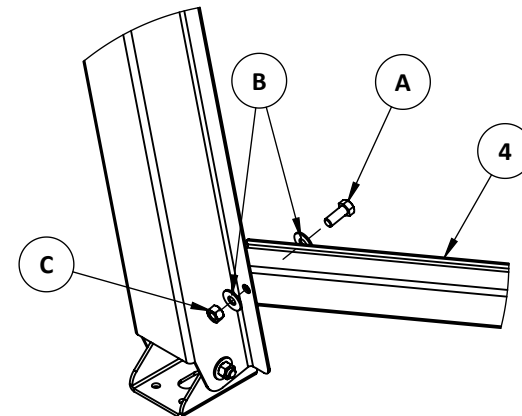
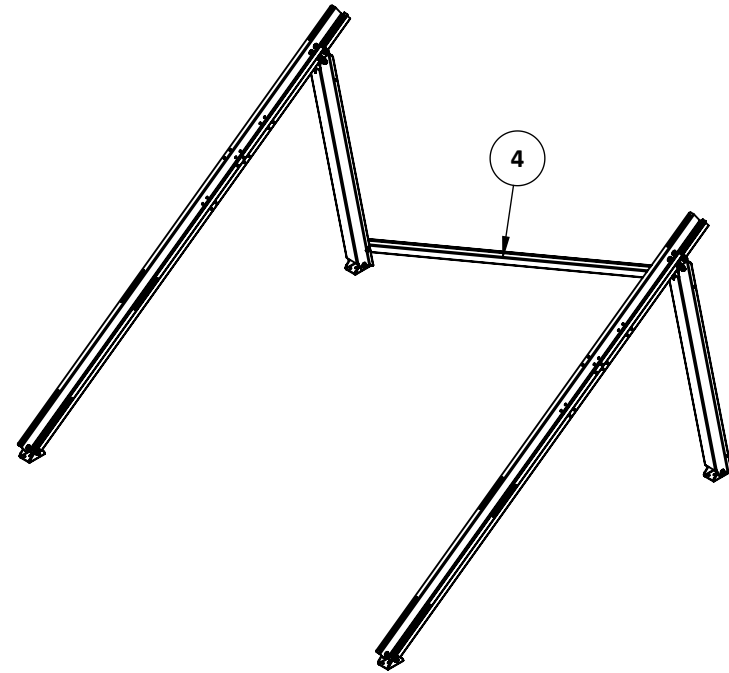



6.0 Preparing to Install the Rails

Position the Rails on the Elevation Bar in line with the slotted connection points. Measure the spacing based on the width of the PV Modules.

Center the Rails over the frames so that the overhang is even on both ends. The Elevation Bar is slotted to allow adjustment. Fasten the rail in the 'Starter Position' and adjust adjacent rails as required.

⚠ Do not torque until rails are properly spaced.

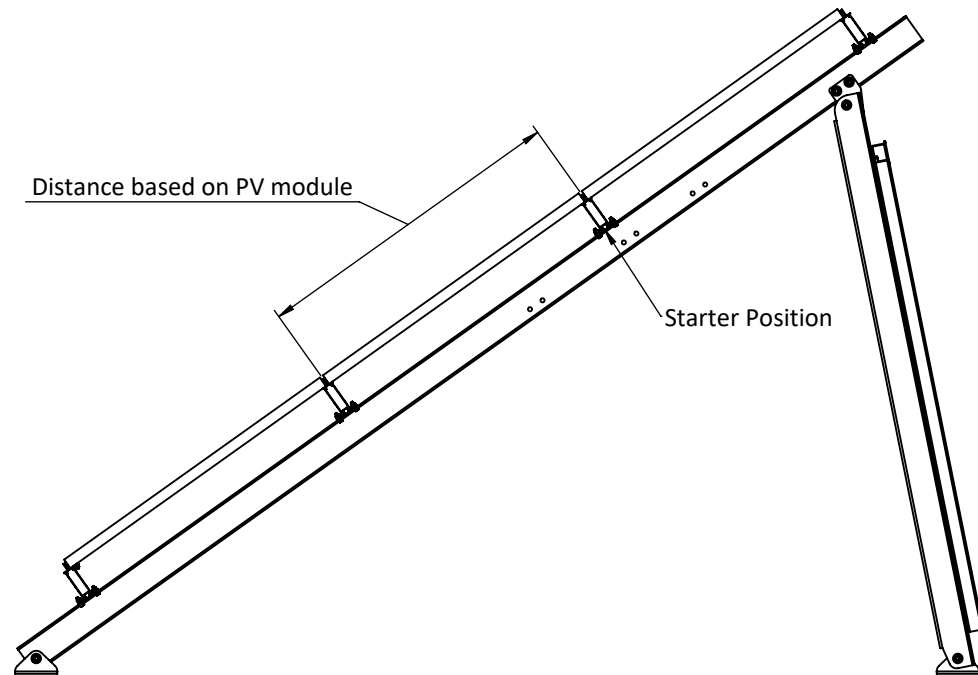



6.1 Installing the Rails



D

0.312" x 1.000"
Flanged Hex Bolt
x32



E

0.312"
Flat Washer
x64



F

0.312"
Nylock Nut
x32



G

Typhoon
Clip C
x32

Once the Rails have been centered, roll the Typhoon Clip B into the groove of the Rail and position it over top of the bolting holes on the Elevation Bar. Use the hardware provided to bolt it in place.

i Ensure the Rail spacing fits the modules correctly before tightening connections.

i Torque to 15 lbs.ft

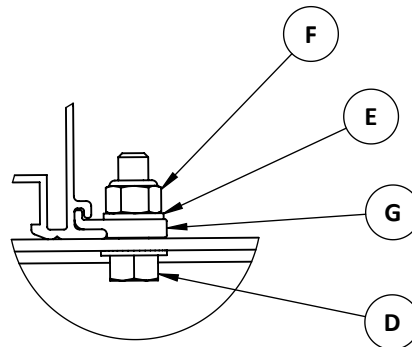
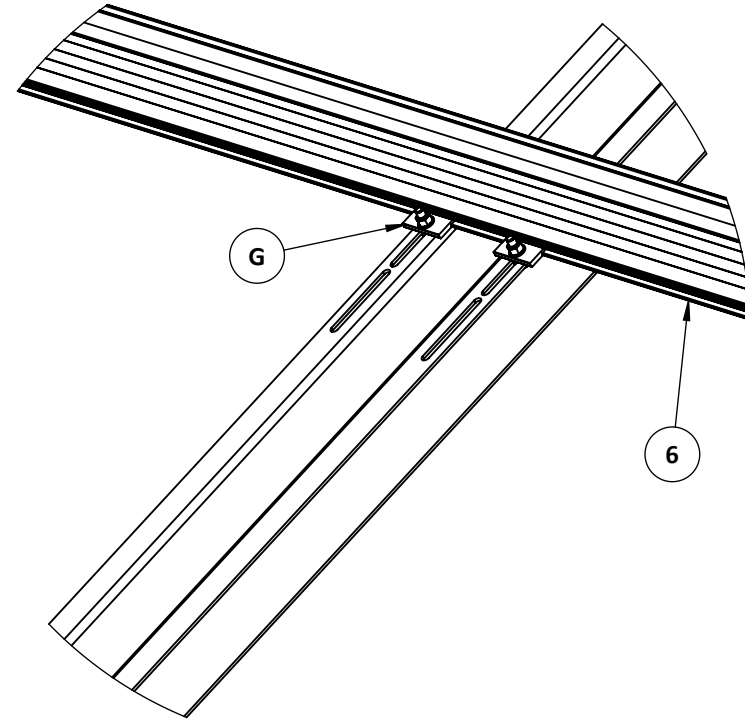



7.0 Preparing to Install the PV Modules

To prepare for installing the PV-Modules, begin by spacing the Typhoon Rails. They are to be spaced according to the PV-modules. The bolting holes in the module frames must overhang the flange of the Typhoon Rail.

Verify the spacing before torquing the Rail hardware. Ensure the spacing is even across the length of the Rails.

The PV-Modules will rest on the flanges of the Typhoon Rails. The modules should be centered on the Rails.

⚠ PV Modules must be bolted at 4 points

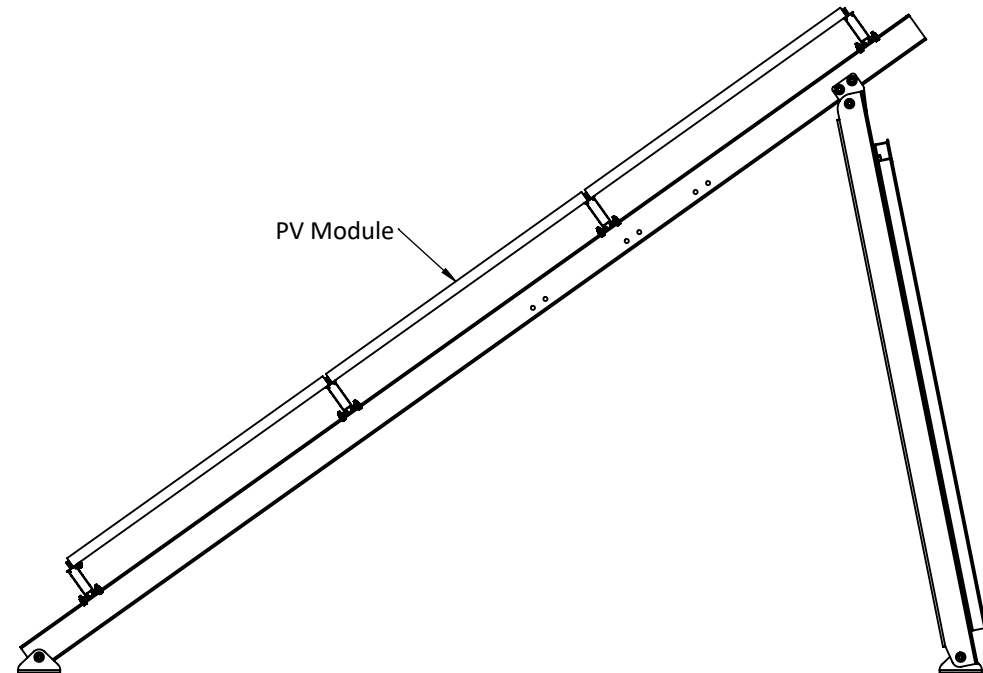



7.1 Installing the PV Modules (72 Cell)



I

0.250" x 0.750"
Hex Bolt
x36



J

0.250
Flat Washer
x36



K

0.250
Nyloc Nut
x36



L

Typhoon
Clip A
x36

The PV-modules rest on flanges along the Typhoon Rails. The center rails will hold a module on each side. Place all of the PV-modules onto the rails and check their positioning.

i Make sure to arrange the PV-modules so that they are centered along the length of the Rails.

Once the PV-modules have been positioned and any adjustments have been made, secure the PV-modules down using the Typhoon Clip C's and the provided hardware.

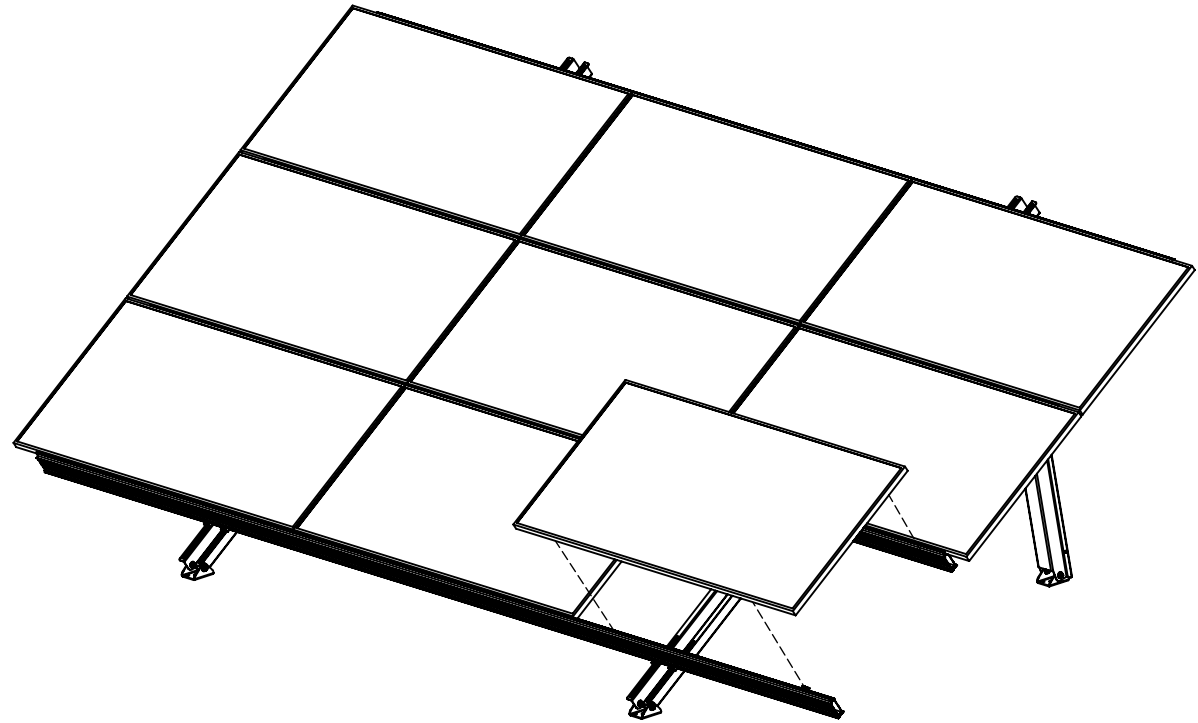

i Torque to 5 lbs.ft

i There may be a gap here

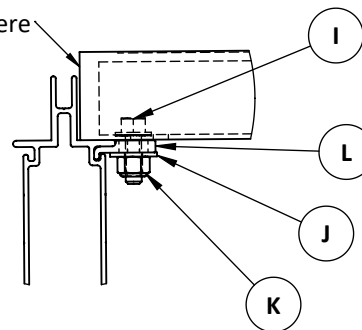



7.2 Installing the PV Modules (60 Cell)



I

0.250" x 0.750"
Hex Bolt
x48



J

0.250
Flat Washer
x96



K

0.250
Nyloc Nut
x48



L

Typhoon
Clip A
x48

The PV-modules rest on flanges along the Typhoon Rails. The center rails will hold a module on each side. Place all of the PV-modules onto the rails and check their positioning.

- i** Make sure to arrange the PV-modules so that they are centered along the length of the Rails.

Once the PV-modules have been positioned and any adjustments have been made, secure the PV-modules down using the Typhoon Clip C's and the provided hardware.

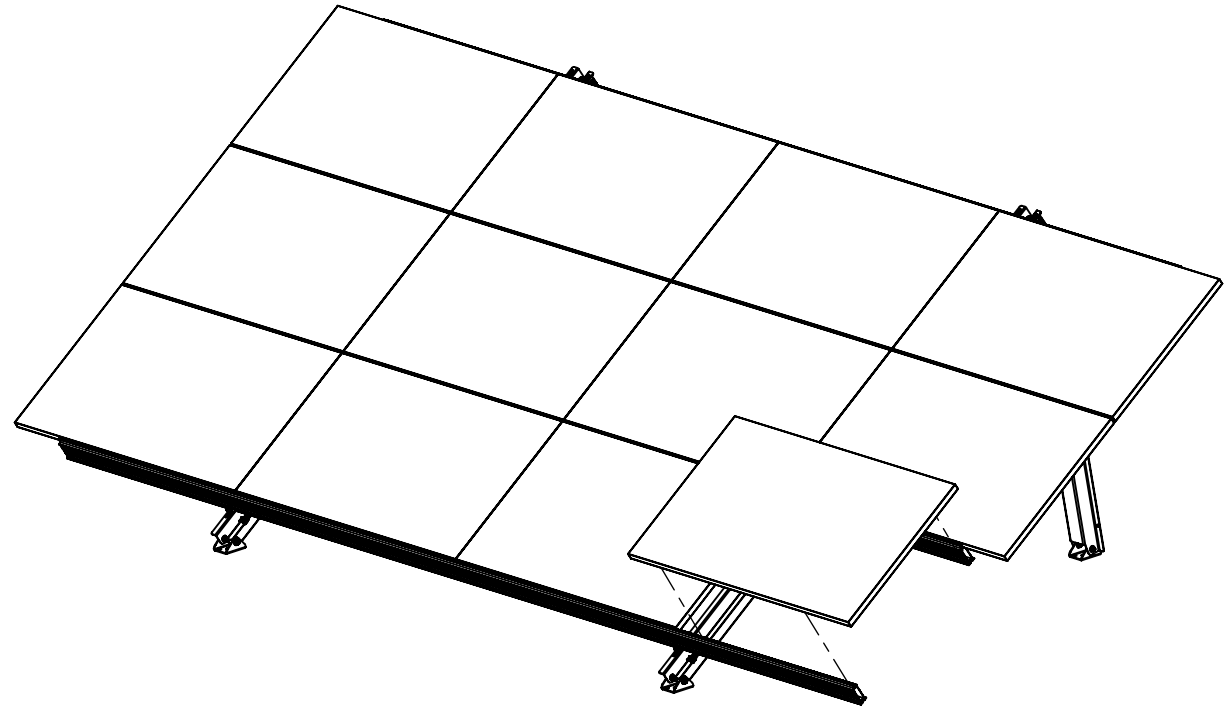

- i** Torque to 5 lbs.ft

- i** There may be a gap here

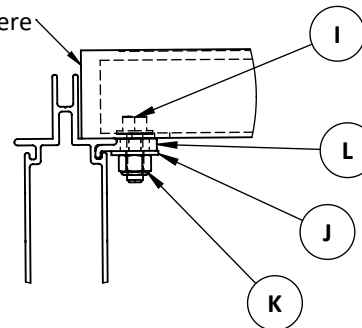



The PV-Modules are bonded to the rails using disc bonding washers. Each PV-module requires at least one bonding washer.

The bonding washer must be located in between the PV-Module frame and the rail flange. Bolts must be properly torqued.

i Torque to 5 lbs.ft

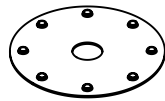

Bonding Washer (H)

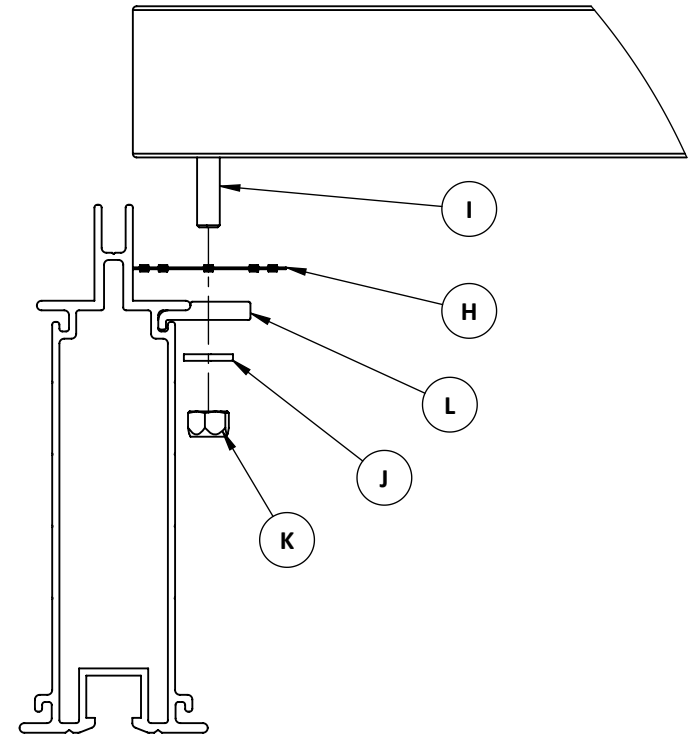



9.0 Installing the HL Brace



A

0.500" x 1.250"
Hex Bolt
x12



B

0.500"
Flat Washer
x24



C

0.500"
Hex Nut
x12

OPTIONAL

i The HL Brace is an optional support used for high snow load locations, or for installations with piles to add rigidity to the system.

Fasten the second Pivot Bracket to the Elevation Bar at the lowest connection point. Install the four bolts and fully tighten.

Loosen the bolts on the back foot and slide in the HL Brace. The slots allow it to be installed without fully removing the hardware. Swing it up and bolt the top end to the Pivot Bracket.

i The HL Brace is only designed to work with the racking installed at 35°

i Torque to 57 lbs.ft

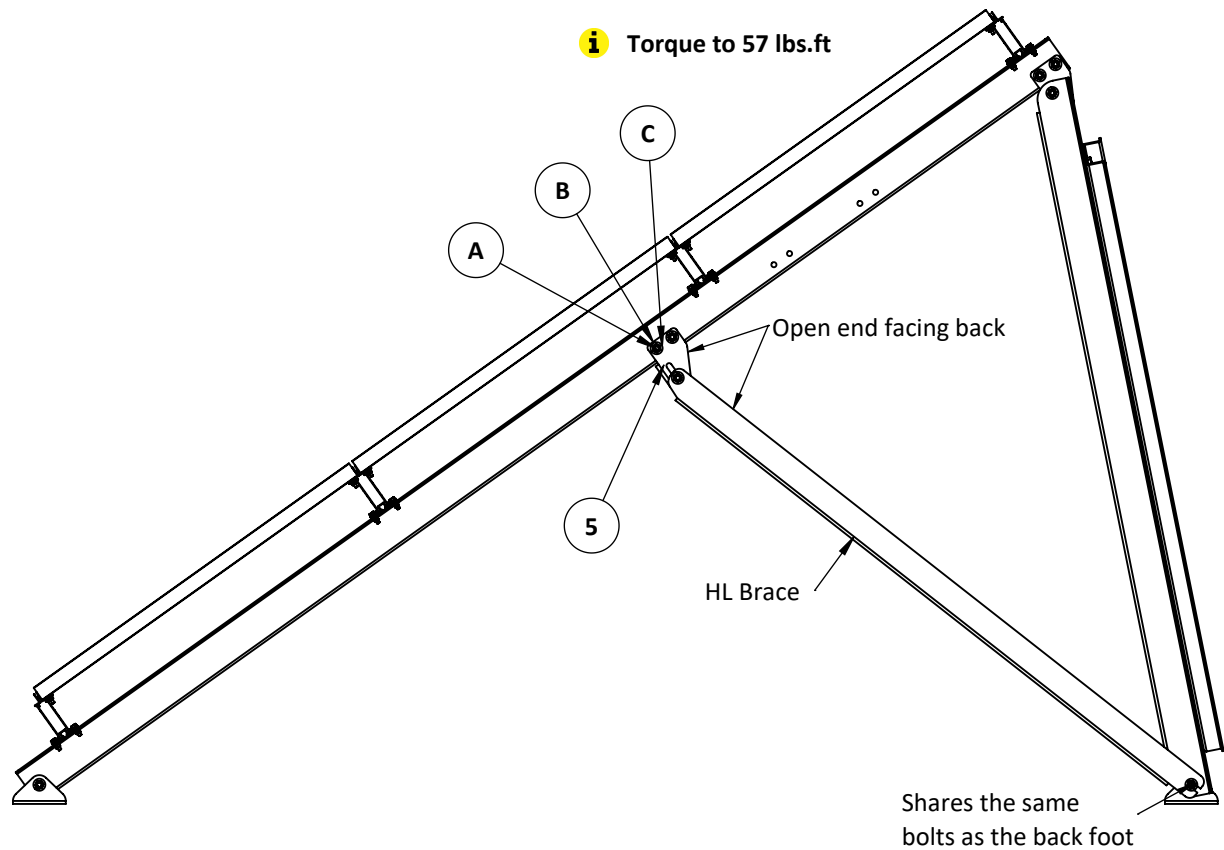



Introduction

The primary purpose of regular inspection and maintenance is to ensure the safe and efficient operation of your ground mount solar racking system. By following these guidelines, you can identify and address issues before they lead to performance degradation or safety concerns.

Safety Precautions

Before conducting any inspection or maintenance activities, adhere to the following safety precautions:

- **Safety Gear:** Wear appropriate personal protective equipment (PPE), including safety glasses, gloves, and a hard hat.
- **Secure Access:** Ensure you have safe and secure access to the solar racking system. Use ladders or scaffolding when necessary, and be aware of potential fall hazards.
- **Electrical Safety:** If inspecting electrical components, follow electrical safety procedures. Always de-energize and lockout/tagout electrical systems before inspection.
- **Teamwork:** Whenever possible, work with a partner who can assist with safety measures and procedures.

Regular Inspection

Visual Inspection

Perform visual inspections on a regular basis to identify any visible issues:

- Check for loose or missing bolts, nuts, or fasteners.
- Inspect for signs of corrosion or rust on steel and aluminum components.
 - Replace components with excessive corrosion as needed.
 - Remove surface corrosion with a light abrasive.
- Examine the overall condition of the racking structure for any damage.
- Ensure that the solar panels are securely fastened and not damaged.

Torque Check

Regularly check the torque of bolts and nuts to maintain the structural integrity of the system:

- Use a torque wrench to verify that all fasteners are tightened to the manufacturer's specifications.

Electrical Inspection

Inspect electrical components to ensure safe and efficient operation:

- Examine electrical connections for signs of wear, corrosion, or loose wires.
- Check the condition of junction boxes, wiring, and connectors.
- Monitor the performance of inverters and other electrical equipment as per the manufacturer's recommendations.

Structural Integrity

Ensure the structural integrity of the racking system:

- Check for any signs of settling or shifting of foundations.
- Inspect for any signs of stress or damage to the mounting rails and supports.

Frequency

Regular inspection intervals are essential to maintain the reliability of your solar racking system. Consider the following recommended inspection frequencies:

- **Annually:** Electrical inspections, structural integrity checks, bolt torque check, and a comprehensive visual inspection.

However, it's essential to adapt the inspection frequency to your specific environmental conditions. If your system is exposed to harsh weather or other challenging factors, more frequent inspections may be necessary.



MODULE AREA	STANDARD TITAN LITE (35-55 DEGREES)	45 DEGREE STANDARD TITAN LITE	35 DEGREE HIGH LOAD TITAN LITE
Less than 1.83 m ² (19.7ft ²)	2.41 kPa (50.32 psf)	4.18 kPa (87.20 psf)	6.06 kPa (126.67 psf)
Less than 1.95 m ² (21.0 ft ²)	3.00 kPa (62.59 psf)	5.19 kPa (108.46 psf)	7.54 kPa (157.55 psf)
Less than 2.17 m ² (21.4 ft ²)	2.69 kPa (56.23 psf)	4.67 kPa (97.45 psf)	6.78 kPa (141.55 psf)
Less than 2.32 m ² (25.0 ft ²)	2.53 kPa (52.78 psf)	4.38 kPa (91.46 psf)	6.36 kPa (132.86 psf)
Less than 2.37 m ² (25.5 ft ²)	2.46 kPa (51.47 psf)	4.27 kPa (123.56 psf)	6.20 kPa (129.56 psf)
Less than 2.56 m ² (27.6 ft ²)	2.29 kPa (47.81 psf)	3.97 kPa (82.86 psf)	5.76 kPa (120.37 psf)

The above table presents the design load limitations of the Titan Lite 2L system. The values represent maximum combined wind and snow loads factored as per the NBCC 2015 and exclude the dead load associated with the modules.

Module Area = Module Cord Length X Module Width

