

Whizbang Jr. – Installation Instructions

The Whizbang Junior provides highly accurate current sensing when used with compatible MidNite Solar products. However, for our customers that already own similar products, the Whizbang Jr. has been designed for cooperative attachment. **If you already own another battery-monitoring product and wish to continue using it, skip down to step 1.2.**

Step 1.1 (Whizbang Jr. only): Attach Whizbang Jr. to 500A/50mV Deltec MKB Shunt or equivalent (see Figure 1).

WARNING: The Whizbang Jr. is designed for low-side shunt measurement. Make certain shunt is attached to battery-negative, not battery-positive.

- A. Remove sensing screws from shunt, including lock-washer and flat-washer. Put flat washers to the side, they will not be used.
- B. With lock-washers attached, guide both screws through the Whizbang terminals.
- C. Slide on provided 1/8" long spacers over screws on the back-side of the Whizbang Jr.
- D. Carefully guide the Whizbang Jr. to the shunt. The Whizbang Jr.'s purple wire should be pointing toward the battery cable side of the shunt. Hand-tighten screws to provide a solid connection. Loosen and retighten screws to ensure a snug fit. **Skip to 2.1.**

Step 1.2 (Cooperative): Attach Whizbang Jr. to 500A/50mV Deltec MKB Shunt or equivalent (see Figure 2).

WARNING: The Whizbang Jr. is designed for low-side shunt measurement. Make certain shunt is attached to battery-negative, not battery-positive.

- A. Remove sensing screws from shunt. Gather their attached lock-washers. The pre-mounted screws and flat-washers will not be used. Put them to the side.
- B. Place provided 1/4" long spacers into Whizbang terminal recesses.
- C. Attach lock-washers to included stainless-steel 3/4" screws, then slide on #8 ring terminals w/attached 3rd party wiring.
- D. Guide both screws through the spacers and Whizbang terminals.
- E. Slide on provided 1/8" long spacers over screws on the back-side of the Whizbang Jr.
- F. Carefully guide the Whizbang Jr. to the shunt. The Whizbang Jr.'s purple wire should be pointing toward the battery cable side of the shunt. Hand-tighten screws to provide a solid connection. Loosen and retighten screws to ensure a snug fit.

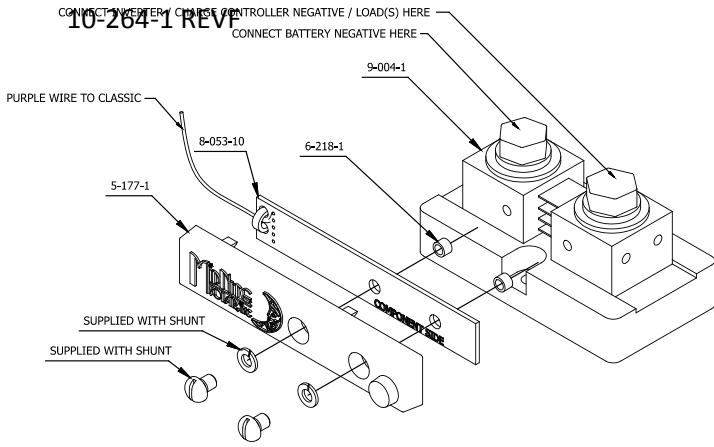

Figure 1 – Whizbang Jr. Only

Included Hardware:

- 2x 6-218-1 1/8" long, 1/4" O.D., .171" I.D. Alum. Spacer
- 2x 6-210-1 1/4" long, 1/4" O.D., .171" I.D. Alum. Spacer
- 2x 6-239-1 3/4" long #8-32 Phillips, Stainless.

Not-Included Hardware:

- 1x 9-004-1 Deltec MKB Series, 500A, 50mV Shunt.
- 2x None. #8 Ring Terminals.

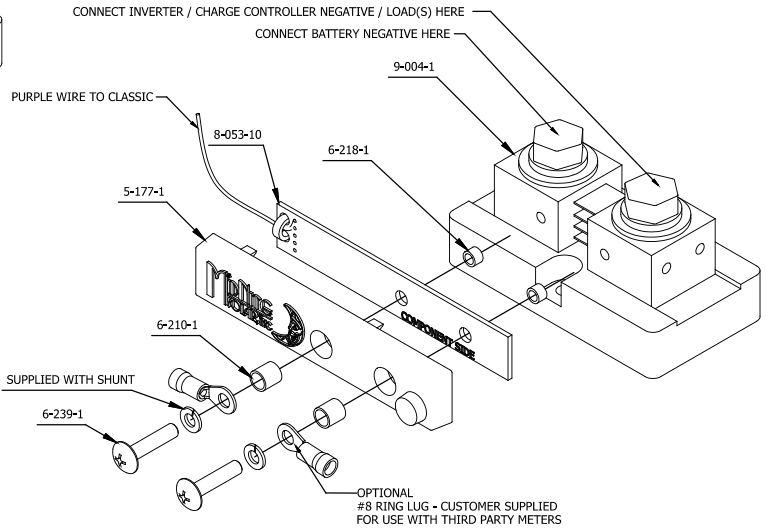

Figure 2 – Whizbang Jr. and 3rd party connections

Step 2.1: Attach Whizbang Jr. to MidNite Classic.

- A. Strip approximately 3/16" from the end of the 22AWG purple Whizbang Jr. wire. Twist the strands together to reduce fraying.
- B. Feed wire through preferred conduit opening.
- C. Secure wire to **Classic AUX2+ input**, see Fig. 3 below.

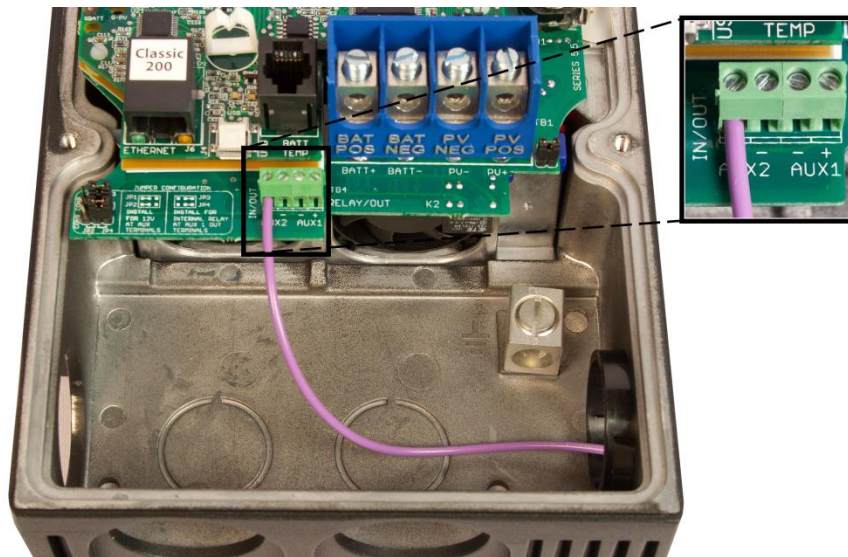

Figure 3 – Whizbang Jr., connection to Classic.

The Whizbang Junior will need newer firmware loaded into the Classic and MNGP (MidNite Graphics Panel). You will want to make sure you have Software Revision 1758 or newer. To check your revision, press the status button 6 times and look at the Classic Revision. Or if you are using a Classic Lite you can check the revision by going to the INFO tab on the Local Status Panel. Visit the following link and follow directions to bring your Classic/MNGP up to date.

<http://www.midnitesolar.com/firmware.php?firmwareProduct ID=1>

SET UP:

From the Main Menu, highlight "AUX" and press Enter. Press the right arrow to highlight the current AUX-2 mode. Press the soft-right key to enter the AUX-2 setup submenu. Cycle using the up/down arrows until "WHIZBANG JR." is highlighted. Press Enter to select this mode. The MNGP will save this mode to the Classic. Press the Status button to return to the Home status screen.

The LED on the WB Jr. circuit board will begin flashing approximately every 5 seconds if properly connected to the Classic.

STATUS:

Pressing the STATUS button three times will bring you to the Whizbang Jr. status screen. There are 4 displayed items here, see Figure 4 below.

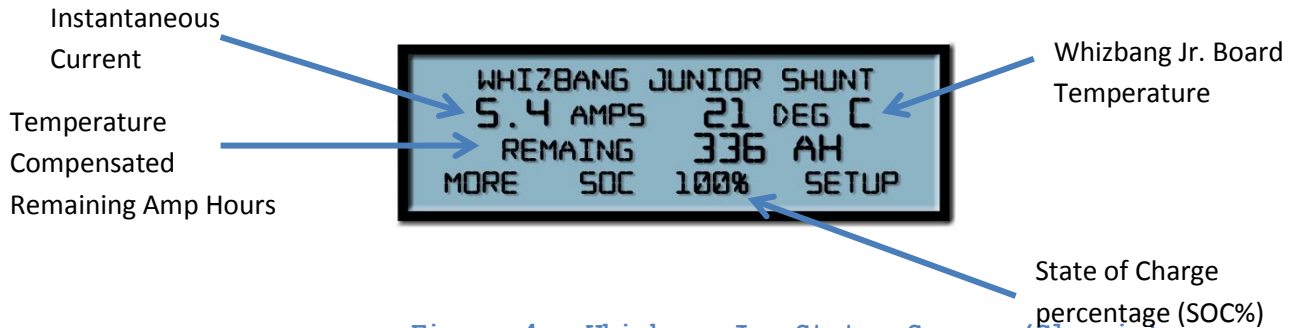

Figure 4 - Whizbang Jr. Status Screen (Classic)

This status screen updates live. It displays: Whizbang Jr. temperature, instantaneous battery current, remaining temperature compensated Amp-hours and SOC% (if SOC is flashing then the battery has not seen a full charge by going to float for the first time after turning unit on) Pressing the upper Left button (Left Soft Key) displays the accumulated Amp Hours screen as seen in figure 5.



Figure 5 - Whizbang Jr. "More" Screen

When the battery is receiving a charge, the accumulated positive Amp-hours figure will increase, as will the total Net figure. When the battery is being discharged, the accumulated negative Amp-hours will increase, and the total (Net) Amp-hours will decrease. As battery charging is not 100% efficient, the total accumulated Amp-hours or "NET AMP-HOURS" should remain positive after a discharge-charge cycle. A typical battery efficiency is 80 to 85%.

The Net Amp-hours tally can be configured to reset every time the Classic goes to float. To set this option, go to the "TWEAKS" menu and press "MORE" four times. Select "WBRST" and press the UP or DOWN arrow keys to select "YES." Press Enter to save. "NO" (or no reset) is the default.

If set to "YES", only the Net-Amp-Hours will reset. The accumulated +AH and -AH will keep increasing. These values are stored into non-volatile memory every night at midnight. If the Classic were to lose power, it would recover accumulated Amp-hours from the previous day. These values can be cleared from the Classics Logs menu, please consult the Classics owner's manual for more info.

From the WBJr main screen in figure 4 press the upper right button (Right Soft Key) to take you to the first set up screen.

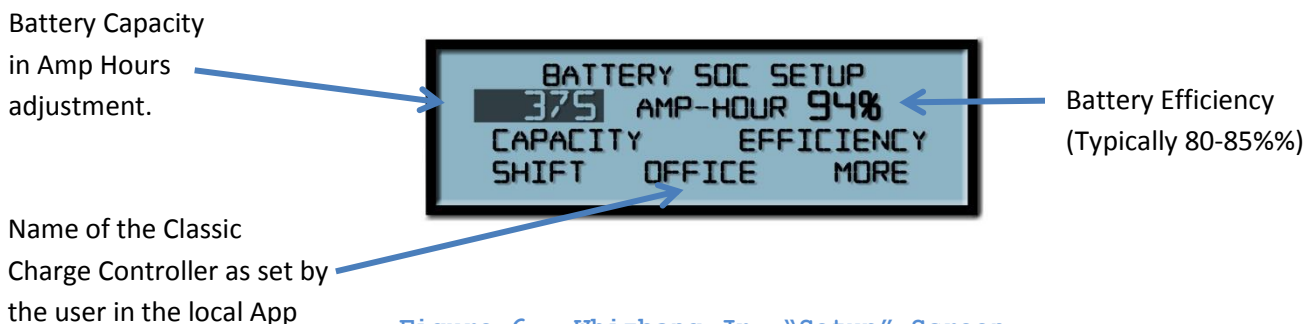

Figure 6 - Whizbang Jr. "Setup" Screen

On this screen we need to set the Capacity of the battery bank. Remember that batteries in series do not add in Amp Hours, only batteries in parallel. (Example- 2 strings of 4 6-volt golf cart batteries that are 220 Amp Hours each wired for 24 volts would be 440Ah) Holding Shift while changing the Ah capacity will change in steps of 100. The Default setting is 400Ah.

We need to set the Efficiency. Typically, on a flooded battery this will be between 80 and 85%. On a sealed lead acid or Lithium battery it can be higher. If there is any question you should shoot for a lower efficiency, not a higher one. You can also contact your battery supplier for help with that value. After

both of these are set, press Enter to save them. Next, press the upper right button, (Right Soft Key) to continue with setup.

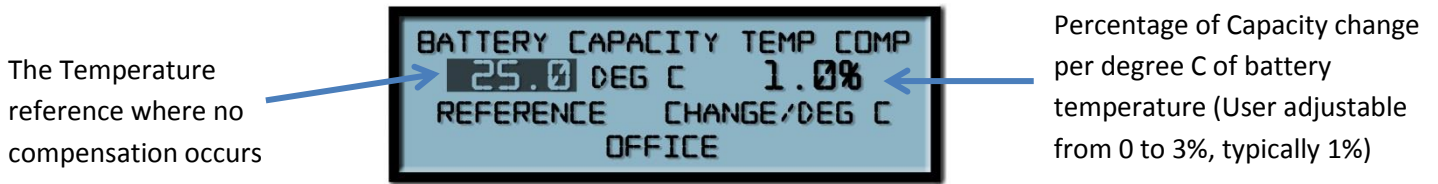

Figure 7 - Whizbang Jr. "Setup-2" Screen

On the second setup screen "figure 7" we need to set the battery temperature we reference to for temperature compensation for capacity change and voltage adjustment. As a battery changes in temperature, its apparent capacity changes and the voltage we charge it to needs to change. If the battery temperature is above the "Reference Point" (Hot) we gain capacity and lower the charge voltage. If the battery temperature is below the reference point (Cold) we lose capacity and raise the charge voltage. Most standard batteries use 25 Degrees Celsius as their "Reference Point". If your battery uses something other than 25C for a reference value, this is where you would set it.

We also have to set the percentage of capacity lost or gained for every degree Celsius we are below or above the reference point. This value can be set from 0 to 3%, where 0 is disabled. Typically, a lead acid battery is 1% per degree C. When both values are set press Enter to save these changes and then press Status to return to the home screen.

For help with any of these battery specific values, please contact your battery supplier/manufacturer.

Also note that on the Home screen the Charge stage message in the bottom right corner will toggle between the current stage and the actual state of charge percentage after it goes to float for the first time.

WHIZBANG JR. ASSISTED CHARGING:

One feature of the Whizbang Jr. is the ability to end an Absorb charge based on Ending Amps. In this mode, if the battery current falls below a programmable threshold for one minute, the Classic will go to Float, meaning that the batteries have been fully charged.

To enable Whizbang Jr. assisted charging, select "CHARGE" from the main menu. Select "ADVANCED." Press the soft-left key until the annunciator above it reads "SHUNT" (selecting "CLASC" uses the Classic's internal shunt instead). Press Enter to save your choice.

Setting the Ending Amps value properly is important. Setting this value too high will lead to under-charged batteries. Setting it too low may make it

impossible to reach. In which case, the Classic will transition to Float based on Absorb time. Similarly, an Ending Amps setting of "<0.0" will disable this feature, causing the Classic to transition to Float based on Absorb time only. Consult your battery manufacturer's literature to determine recommended Ending Amps.

Note: If you have two or more Classics connected using Follow-Me mode, the other Classics should follow the Classic connected to the Whizbang Jr.

TROUBLESHOOTING:

If the Classic's Whizbang Jr. status screen (see Fig. 4) shows the Whizbang Jr.'s board temperature sitting at -50°C after initial setup, then the Whizbang Junior is NOT communicating with the Classic's AUX-2 circuitry. Here are some tips in troubleshooting this scenario.

- Is the Classic firmware up to date? Check the Classic's status display for main firmware/MNGP firmware versions.
- Does the Whizbang Jr.'s purple wire make a solid connection with the Classic AUX2+ input? Is the Whizbang Jr. securely attached to the shunt? Is the shunt attached to battery-negative? Is the Classic tied to battery-negative?
- Is the Classic's AUX-2 setup mode set to "WHIZBANG JR."?
- Check the Whizbang Jr.'s LED

Behavior	Meaning	Suggests
Blinks ON every 5 seconds.	The Whizbang Jr. is receiving data-requests and responding.	The Whizbang Jr. is receiving data. Check Whizbang status screen.
Solid ON	The Whizbang Jr. has power, but there appears to be no communication.	AUX2 mode misconfigured. Revisit page 2.
Solid OFF	The Whizbang Jr. has no power.	Improper wiring and/or AUX2 mode misconfigured.
Blinks rapidly	Hardware Fault	Device may be damaged. Try cycling Whizbang Jr.'s power.

Note: To manually reset accumulated Whizbang Jr. Amp-hour tallies, go to "LOGS" menu and press Enter. There are three entries related to the Whizbang Jr.: "WB Jr. NET Amp-Hours", "WB Jr. (+AH)", and "WB Jr. (-AH)". To erase, select one and use the soft-left or soft-right keys to confirm "YES", or "NO". Once confirmed, the Classic will display "Clearing Data" for a few seconds and then return to the main log menu.

For automatic reset of accumulated amp hours, go to the "Tweaks" menu and press the upper right soft key 4 times to get to the Follow Me menu. Scroll to the right and highlight WBRST. Using the up/down arrow keys, set this to "yes" and press Enter to save. This will reset accumulated amp hours every time the Classic goes to Float.

Step 3.1: Attach Whizbang Jr. to MidNite KID.

- A. Strip approximately 3/16" from the end of the 22AWG purple Whizbang Jr. wire. Twist the strands together to reduce fraying.
- B. Feed wire through preferred conduit opening.

Secure wire to the lowest of the 3 AUX ports (See fig below)

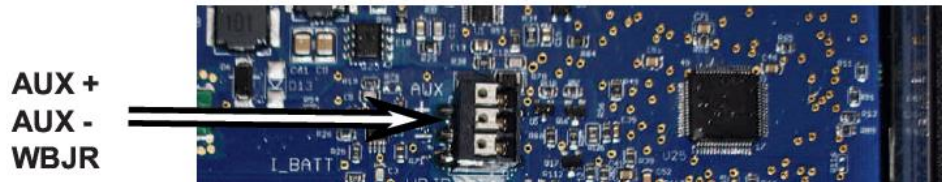

The Whizbang Junior will need firmware 1811 or newer. To check your firmware version: press MAIN MENU, press the right arrow button until the brackets are around TECH then press ENTER button, press the down arrow button until the asterisk * is in front of ABOUT KID CC then press ENTER.

SET UP:

From the Main Menu, press the right arrow until the brackets are around AUX, press ENTER.



Press the up or down arrows until you locate WBJR, Use the right arrow to put the asterisk * in front of AUTO.



Many of the settings you will need for the rest of your set up, you will need from your battery Manufacturer.

Press the SETUP button, the first screens will be to set up your Battery Capacity.



Using the up and down arrow set your Amp hours. Press the right-hand arrow to go to the next screen.

Remember that batteries in series do not add in Amp Hours, only batteries in parallel. (Example- 2 strings of 4 6-volt golf cart batteries that are 220 Amp Hours each wired for 24 volts would be 440Ah)

This screen will be your Battery Efficiency.



Use the up and down arrow to change your settings. Once this is set hit the right arrow.

Typically, on a flooded battery this will be between 80 and 85% On a sealed battery it can be higher. If there is any question you should shoot for a lower efficiency, not a higher one. You can also contact your battery supplier for help with that value.

This screen is the Battery Temperature Reference.



Use the up and down arrow to change your settings. Once this is set hit the right arrow.

As a battery changes in temperature, its apparent capacity changes and the voltage we charge it to needs to change. If the battery temperature is above the "Reference Point" (Hot) we gain capacity and lower the charge voltage. If the battery temperature is below the reference point

(Cold) we lose capacity and raise the charge voltage. Most standard batteries use 25 Degrees Celsius as their "Reference Point".

This screen will be where you set the Battery Change per degree formula.



Use the up and down arrow to change your settings. Once this is set hit the SAVE button in the upper right-hand corner.

We also have to set the percentage of capacity lost or gained for every degree Celsius we are below or above the reference point. This value can be set from 0 to 3%, where 0 is disabled. Typically, a lead acid battery is 1% per degree C.

For help with any of these battery specific values, please contact your battery supplier/manufacturer.

The LED on the WB Jr. circuit board will begin flashing approximately every 5 seconds if properly connected to the KID.

STATUS :

From the Status menu press the right arrow button twice. This status screen updates live. It displays: Whizbang Jr. temperature, instantaneous battery current, remaining temperature compensated Amp-hours and SOC%

When the battery is receiving a charge, the accumulated positive Amp-hours figure will increase, as will the total Net figure. When the battery is being discharged, the accumulated negative Amp-hours will increase, and the total (Net) Amp-hours will decrease. As battery charging is not 100% efficient, the total accumulated Amp-hours or "NET AMP-HOURS" should remain positive after a discharge-charge cycle.

TROUBLESHOOTING:

- Does the Whizbang Jr.'s purple wire make a solid connection with the KID's AUX input?
- Is the purple wire clear of breaks or faults?
- Is the Whizbang Jr. securely attached to the shunt?
- Is the shunt attached to battery-negative?
- Is the KID tied to battery-negative?
- Is the KID's AUX setup mode set to "WHIZBANG JR."?
- Check the Whizbang Jr.'s LED

Behavior	Meaning	Suggests
Blinks ON every 5 seconds.	The Whizbang Jr. is receiving data-requests and responding.	The Whizbang Jr. is receiving data. Check Whizbang status screen.
Solid ON	The Whizbang Jr. has power, but there appears to be no communication.	AUX mode misconfigured.
Solid OFF	The Whizbang Jr. has no power.	Improper wiring and/or AUX mode misconfigured.
Blinks rapidly	Hardware Fault	Device may be damaged. Try cycling Whizbang Jr.'s power.

MidNite Solar 17722 - 67th Ave NE Arlington, WA 98223
PH 360.403.7207 Fax 360.691.6862
www.midnitesolar.com