

User Manual

Battery Energy Storage System

Soluna HV Pack(L-E) Series



About this Specification

This manual provides comprehensive instructions for installing the Soluna HV Pack (L-E)Series. It is imperative to thoroughly read this manual before attempting to install the product and to follow the instructions diligently throughout the installation process.

If you have any doubts about the requirements, recommendations, or safety procedures described in this manual, please contact Soluna immediately for advice and clarification.

The information contained in this manual is accurate at the time of publication. However, due to ongoing updates to product design and technical specifications, our company reserves the right to make changes at any time without prior notice. Additionally, the illustrations included in this manual are intended to aid in explaining system configuration concepts and installation instructions. The items depicted in the illustrations may differ from the actual items at the installation site.

SOLUNA (SHANGHAI) CO.,LTD reserves the copyright of this document.

1. Introduction.....	05
2. Features.....	06
3. Safety Precautions.....	07
3.1 Warning Sign	07
3.2 Safety Instructions.....	08
3.2.1 Risks of Explosion.....	08
3.2.2 Risks of fire	08
3.2.3 Risks of electric shock.....	08
3.2.4 Risks of damage to the battery pack	08
3.3 Battery handling guide.....	09
3.4 Response to emergency situations.....	09
3.4.1 Leaking batteries	09
3.4.2 Inhalation.....	09
3.4.3 Eye contact	09
3.4.4 Skin contact.....	09
3.4.5 Ingestion.....	10
3.4.6 Fire.....	10
3.4.7 Wet batteries.....	10
3.4.8 Damaged batteries	11
3.5 Qualified installers.....	11
4. Appearance.....	12
5. Technical parameters.....	14
6. Connection Port	17
7. COM Communication Interface Definition	18
8. Installation.....	19
8.1 Unpacking the package.....	19
8.2 Packing lists.....	20
8.3 Installation materials.....	21
8.4 Installation location	21
8.5 Installation tools.....	22
8.6 Installation requirement.....	23
8.7 Wiring Specification.....	25
8.8 Wi-Fi module connection.....	25

Contents

9. Electrical connection.....	27
10. How to operate HV Pack (L-E)	30
11. LED indicator description.....	31
12. Trouble shooting guideline.....	32
13. DOD setting of inverter.....	36
14. Contact us.....	37

1 Introduction

The Soluna HV Pack(L-E) Series is an advanced LFP lithium battery product designed to meet the highest standards of performance and safety. Equipped with a sophisticated Battery Management System (BMS), this high-voltage battery module features CAN communication for seamless integration and monitoring. It includes comprehensive protections against under-voltage, over-voltage, over-current, over-temperature, and under-temperature, ensuring optimal performance and safety under various conditions.

With its high energy density, long lifespan, and robust reliability, the Soluna HV Pack(L-E) Series stands out as a green environmental product you can trust. Its innovative design not only enhances efficiency but also contributes to sustainability, making it an ideal choice for Backup Power, Micro-grid Solutions, and Small Industrial & Commercial Energy Storage Systems.

Features

- **Excellent Safety Performance**

Ensures the highest level of safety under various conditions.

- **Long Cycle Life**

Designed for extended usage without significant performance degradation.

- **Support CAN/RS485**

Allows seamless integration and communication with other systems.

- **Parallel Interconnection**

Enables the connection of several systems in parallel for increased capacity.

- **Expandable Battery Units**

Provides flexibility to scale the system as needed.

- **Backup Power**

Reliable power supply during outages.

- **Micro-grid**

Supports independent and sustainable energy systems.













- **Home Energy Storage System**

Efficiently stores energy for residential use.

3 Safety Precautions

3.1 Warning Signs

Warning signs are essential indicators designed to alert you to conditions that could result in severe injury or significant damage to the device. They serve as critical reminders to exercise caution and take necessary precautions to prevent hazardous situations. The table below outlines the warning signs used in this manual and their meanings:

Sign	Description
	High Voltage Warning: This battery pack operates at high voltage, which can cause severe injury due to electric shock.
	Correct Polarity: Ensure the battery polarity is correctly connected.
	Fire Safety: Keep the battery pack away from open flames or ignition sources.
	Child Safety: Store the battery pack out of reach of children.
	Installation Manual: Thoroughly read the manual before installing and operating the battery pack.
	Heavy Weight Warning: The battery pack is heavy, and improper handling may result in severe injury. Utilize proper lifting techniques.
	Electrolyte Leakage: The battery pack may leak corrosive electrolyte. Handle with care and adhere to appropriate safety procedures.
	Explosion Risk: The battery pack may explode under certain conditions.
	Disposal Instructions: Do not dispose of the battery pack with household waste at the end of its working life. Follow local regulations for disposal.
	Compliance Requirement: Failure to follow the provided requirements and guidelines may lead to physical injury or damage to the device.
	Do not short circuit.
	Grounding conductor This symbol indicates the position for connecting a grounding conductor.

3.2 Safety Instructions

For safety reasons, it is crucial that installers thoroughly familiarize themselves with the contents of this manual and all associated warnings prior to commencing the installation.



General Safety Precautions

Failure to adhere to the precautions outlined in this section can result in serious injury or property damage. Please observe the following safety guidelines:

3.2.1 Risks of Explosion

- Avoid subjecting the battery pack to strong impacts.
- Do not crush or puncture the battery pack.
- Never dispose of the battery pack in a fire.

3.2.2 Risks of Fire

- Do not expose the battery pack to temperatures exceeding 60°C.
- Keep the battery pack away from heat sources, such as fireplaces.
- Avoid exposing the battery pack to direct sunlight.
- Ensure the battery connectors do not come into contact with conductive objects like wires.

3.2.3 Risks of Electric Shock

- Refrain from disassembling the battery pack.
- Do not touch the battery pack with wet hands.
- Keep the battery pack away from moisture or liquids
- Ensure the battery pack is kept away from children and animals.

3.2.4 Risks of Damage to the Battery Pack

- Prevent the battery pack from coming into contact with any liquids.

3.3 Battery Handling Guide

- Use the battery pack strictly as directed in the manual.
- Do not use the battery pack if it appears defective, cracked, broken, or fails to operate correctly.
- Do not attempt to open, disassemble, repair, tamper with, or modify the battery pack as it is not user serviceable.
- Handle the battery pack with care during transportation to avoid damage.
- Avoid impacting, pulling, dragging, or stepping on the battery pack.

3.4 Response to Emergency Situations

The Soluna HV Pack(L-E)Series consists of multiple batteries designed to prevent hazards resulting from failures. However, Soluna cannot guarantee absolute safety. Please familiarize yourself with the following emergency procedure

3.4.1 Leaking Batteries

If the battery pack leaks electrolyte, avoid contact with the leaking liquid or gas. Electrolyte is corrosive and contact may cause skin irritation and chemical burns. If exposed to the leaked substance, follow these steps:

3.4.2 Inhalation

- Evacuate the contaminated area immediately.
- Seek medical attention without delay

3.4.3 Eye Contact

- Rinse eyes with flowing water for at least 15 minutes.
- Seek medical attention immediately.

3.4.4 Skin Contact

- Wash the affected area thoroughly with soap and water.
- Seek medical attention immediately.

3.4.5 Ingestion

- Induce vomiting.
- Seek medical attention immediately.

3.4.6 Fire Response Procedures

In the event of a fire, always have an ABC or carbon dioxide extinguisher on hand.



The battery pack may ignite if heated above 150°C. If a fire occurs where the battery pack is installed, follow these steps:

- **Extinguish Early**

Attempt to extinguish the fire before the battery pack ignites.

- **Safe Relocation**

If extinguishing is not possible but time allows, move the battery pack to a safe area before it catches fire.

- **Evacuate**

If the battery pack has already caught fire, do not attempt to extinguish it. Evacuate the area immediately.



Caution: If the battery catches fire, it will emit noxious and poisonous gases. Do not approach the fire.

3.4.7 Wet Batteries

If the battery pack becomes wet or submerged in water, do not attempt to access it. Contact Soluna or your distributor for technical assistance immediately.

3.4.8 Damaged Batteries

Damaged batteries are hazardous and must be handled with extreme caution. They are unfit for use and may pose a danger to people or property.

If the battery pack appears damaged, pack it in its original container and return it to Soluna or your distributor.



Leakage and Flammability: Damaged batteries may leak electrolyte or produce flammable gas. If you suspect such damage, contact Soluna for advice and information immediately.

3.5 Qualified Installers

This manual, along with the tasks and procedures described herein, is intended for use by skilled professionals only. A skilled professional is defined as a trained and qualified electrician or installer who possesses all of the following skills and experience:

- **Functional Knowledge**

Understanding of the principles and operation of on-grid systems.

- **Risk Awareness**

Awareness of the dangers and risks associated with installing and using electrical devices and the acceptable methods for mitigating these risks.

- **Installation Proficiency**

Expertise in the installation of electrical devices.

- **Adherence to Guidelines**

Knowledge of and compliance with this manual, including all safety precautions and best practices.

- **Battery Maintenance**

Only authorized personnel should perform maintenance. Turn off the battery before maintenance. Periodically check voltage, SOC, and cables for damage or wear. Perform balancing maintenance (fully charge) every three months.

- **Installation Environment Requirements**

Avoid flammable, explosive, or corrosive materials. Keep out of children's reach and avoid high temperatures. Ensure proper ventilation and avoid electromagnetic interference. Install in a sheltered, well-ventilated area, within the appropriate temperature and humidity range, and below 2000 meters altitude.

4 Appearance



6K Pack HV(L-E)



10K Pack HV(L-E)



15K Pack HV(L-E)

Product name	6K Pack HV(L-E)	10K Pack HV(L-E)	15K Pack HV(L-E)
Width(mm)	654	654	654
Depth(mm)	227	227	227
Height(mm)	971	971	1205
Weight(kg)	74	103	146.8

4 Appearance

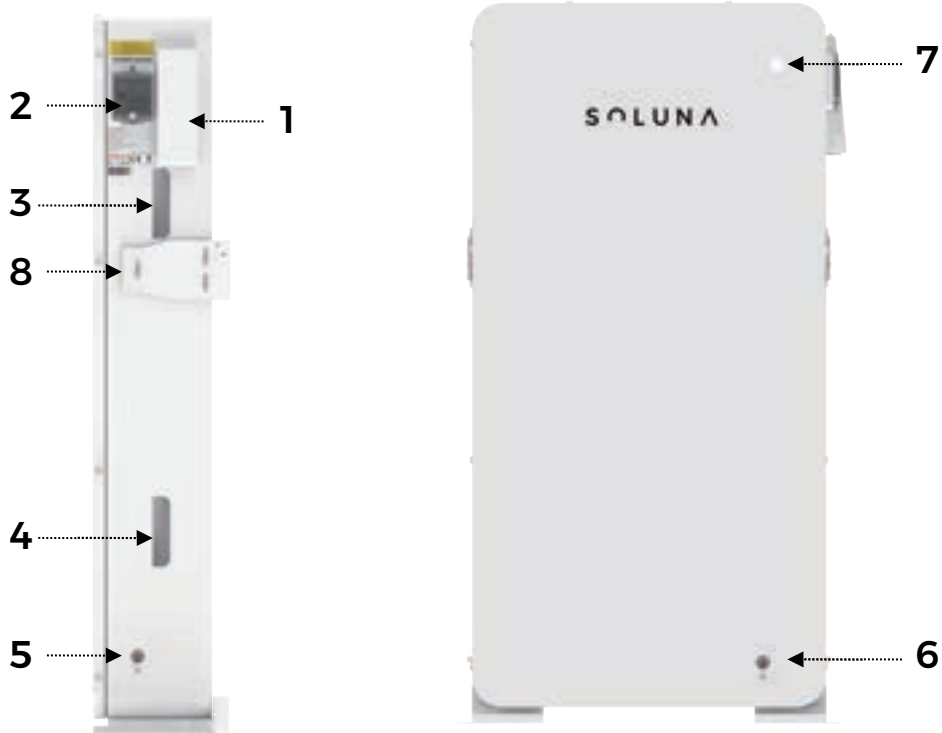

Number	Name	Description
1	Cable connection interface	This is where cables are connected to the device, allowing for communication or power transfer.
2	Power ON/OFF switch	Used to turn the device on or off.
3/4	Handle	Carry or maneuver the device.
5/6	Grounding points	Ensure the device is properly grounded to prevent electrical hazards.
7	Status indicator light	Displays the operational status of the device, such as power on, power off, error states, etc.
8	Bracket attached to wall	Allows the device to be securely mounted on a wall for stability and space-saving purposes.

5 Technical parameters

Physical Characteristics			
Model	6K Pack HV (L-E)	10K Pack HV (L-E)	15K Pack HV (L-E)
Width(mm)	654	654	654
Depth(mm)	227	227	227
Height(mm)	971	971	1205
Weight(kg)	74	105	143
Electrical Characteristics			
Battery type	LFP		
Total Energy Capacity	6kWh	10kWh	15kWh
Usable Energy Capacity	5.4kWh	9kWh	13.5kWh
Battery Capacity (Nominal)	40Ah		
Nominal Voltage	153.6V	268.8V	384V
Usable Voltage Range	134.4~168V	235.2~294V	336~420V
Charge voltage (CV)	168V	294V	420V
Discharge cut-off voltage	134.4V	235.2V	360V
Charge/Discharge Current (Nominal)	20A/20A		
Charge/Discharge Current (Max)	20A/40A		
Recommended Depth of Discharge	80% ^①		
Max. Depth of Discharge	90%		
Number of expandable battery units	10 ^②		
Cycle life @ 25 °C (under standard charge and discharge conditions)	≥8000 ^③		
DC Disconnect	Contactor Fuse		

5 Technical parameters

BMS		
Power consumption	≤100mA (work), ≤0.1mA (sleep)	
Monitoring parameters	System Voltage System Current Cell Voltage Cell Temperature	
Communication	CAN	
Operating Conditions		
Condition	Indoor conditioned	
Operating Temperature	-10~50°C (Charge: 0~50°C, Discharge: -10~50°C)	
Operating Temperature (Recommended)	15~30°C ^④	
Storage temperature	-20~60°C	≤7 days
	-20~45°C	≤1 month
	0~45°C	≤3 months
	0~25°C	≤1 years
Humidity	5%~95%	
Altitude	Max. 2,000m	
Cooling Strategy	Natural Convection	
Reliability & Certification		
Certificates	CE,CEC,UL9540A,IEC626,UL1973,UL9540,IEC62477	
Transportation	UN38.3	
Ingress Rating	IP65	
Warranty		
Please refer to SOLUNA WARRANTY CONDITIONS		

5 Technical parameters

1: Test Conditions: 100% Depth of Discharge (DOD), 0.2 C charge and discharge at +25±2°C for the battery at the beginning of its life. Usable energy may vary with different inverters.

2: Under EMS control, it can be expanded to 100pcs in parallel

3: Note: At 25±2°C of cell under 0.5C/0.5C test condition and 70% End of Life (EOL).

4: For long-term storage: Store battery cells in a temperature range of 5-45°C, with relative humidity below 65%, and in a non-corrosive environment. Charge to 50-55% SOC before storage to prevent significant cycle life reduction.

NOTE

- When a level 1 alarm is triggered, the charge or discharge rate will be reduced.
- When a level 2 alarm is triggered, charge and discharge operations will be limited to 0A.
- Prolonged discharging at currents below 0.5A may lead to inaccuracies in the State of Charge (SOC) calculation.
- Storage SOC: Maintain a State of charge (SOC) between 30% and 50% for storage, and cycle the charge-discharge process every 6 months.
- Store the battery at a temperature range of 15~30 °C, for periods not exceeding one year.

6 Connection Port

Upon removing the cover cap, the connections port of the Soluna HV Pack(L-E) becomes visible. Please refer to the detailed image provided below.

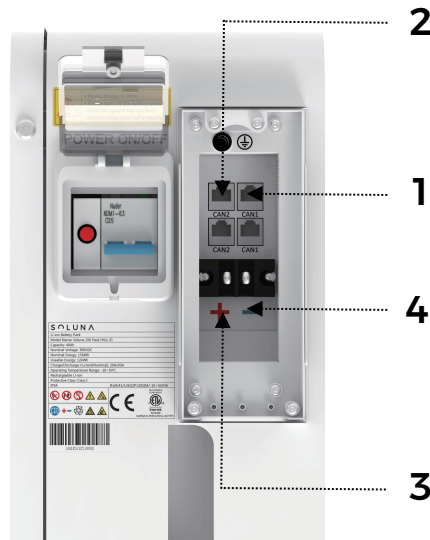

Number	Name	Describe
1	CAN1 port	2PCS,For external communication (inverter) This port allows the battery pack to communicate with the inverter, facilitating power conversion and system integration.
2	CAN2 port	2PCS,For internal communication (BMS) This port enables communication within the Battery Management System (BMS), ensuring efficient battery monitoring and management.
3	Battery+	This is the positive terminal of the battery pack. It is used to connect the positive side of the electrical load or inverter.
4	Battery-	This is the negative terminal of the battery pack. It is used to connect the negative side of the electrical load or inverter.

7 COM Communication Interface Definition

Once the cover plate of the Soluna HV Pack(L-E) is opened, users can view the connection ports of the battery. Please refer to the images below for detailed visuals.

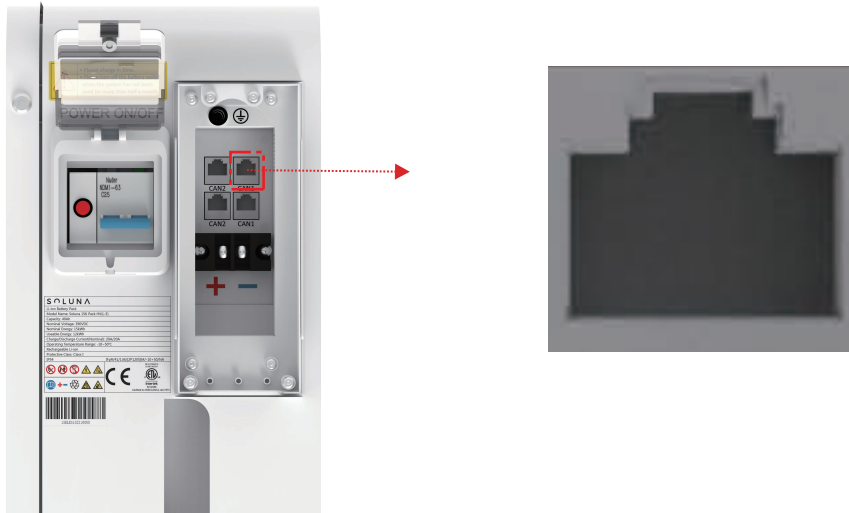

2.7.1 CAN1 port (for inverter communication)







1	2	3	4	5	6	7	8
—	—	—	CAN1H	CAN1L	—	—	—

2.7.1 CAN2 port (for battery communication)

1	2	3	4	5	6	7	8
RS-485A	RS-485B	GND	CAN1H	CAN1L	+12V	CAN2H	CAN2L

8.1 Packing lists

Here is the list of items included in the package, along with their quantities. If any item is damaged or missing, please contact Soluna or your distributor:

Item	Name	Describe	Qty (pcs)	Photo
1	Soluna HV Pack(L-E)	The main LiFePO4 lithium battery unit.	1	
2	PE wire	(Polyethylene)electrical wire	1	
3	Allen wrench (M2.0)	Hex key.Use to drive screws and bolts with hexagonal sockets.	1	
4	M4 Phillips screw	/	4	
5	M6 Phillips screw	/	10	
6	M8 expansion screw	/	8	
7	Wall Bracket	Used to mount the battery pack securely on the wall.	1	

8	CAN communication wire	/	1	
---	------------------------	---	---	---

8.2 Installation materials

These installation materials shall be prepared by installers:

- Charging cables
- Communication cables
- DC breaker

8.3 Installation location

Please make sure that the installation location meets the following conditions:

- The building is designed to withstand earthquakes.
- The location is far away from the sea, to avoid salt water and humidity.
- The floor is flat and level.
- There are no flammable or explosive materials nearby.
- The ambient temperature is between 15 and 30°C.
- The temperature and humidity stays at a constant level.
- There is minimal dust and dirt in the area.
- There are no corrosive gases present, including ammonia and acid vapor.
- The working temperature range: 0 ~50°C, optimum temperature: 15 ~30°C.







Note: Do not place the battery system in direct sun light. it is suggested to build sunshade equipment in cold area the heating system is required.



If the ambient temperature is outside the operating range, the battery pack stops operating to protect itself. The optimal temperature range for the battery pack to operate is 15°C to 30°C. Frequent exposure to harsh temperatures may deteriorate the performance and lifetime of the battery pack.

8.4 Installation tools

The following tools are required to install the battery pack.

Item	Photo	Name
1		Phillips-screwdriver bit
2		Wire cutters
3		Wire stripper
4		Tape measure
5		Drill
6		Network crimper
7		Electrical insulating tape

Use properly insulated tools to prevent accidental electric shock or short circuits. Use adjustable tools and measuring instruments that are certified for precision and accuracy.

When handling the battery pack, it is essential to wear the appropriate safety gear to protect against potential hazards, installers must adhere to the relevant requirements of international standards, such as IEC 60364, or comply with domestic legislation.

1		Safety goggles
2		Safety shoes
3		Insulated gloves

8.5 Installation requirement

Soluna HV Pack(L-E)Series should be installed attached the wall. Eight holes should be drilled on the wall in order to fix the racks of the battery module. Please find the following pictures for details.

1. Drill Holes

Use a percussion drill to create eight holes at the marked positions. The diameter of each hole should be 12mm.

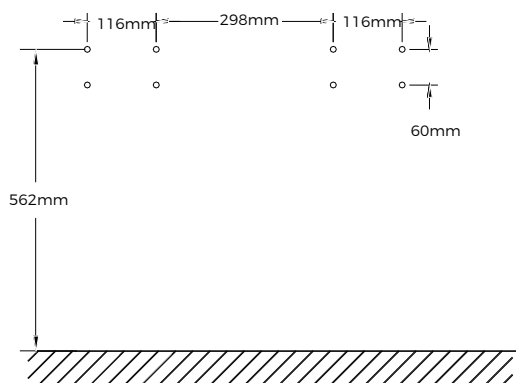

2. Install Wall Brackets

Use 8 expansion screws to attach the wall bracket and the wall mounting bracket to the wall.

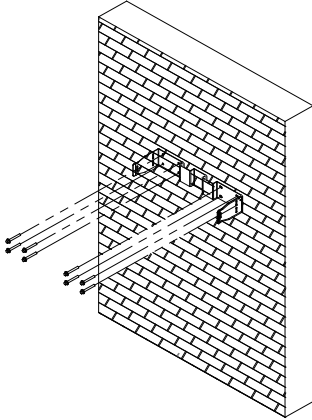

3. Mount Battery

Place the battery module on the wall bracket.



4. Secure Battery

Fasten the battery module to the bracket using 6 M6 screws, with a torque specification of 5-6 N*m.

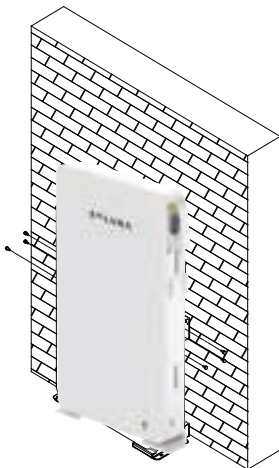

5. Connect Wiring

After securing the battery, install the wire harness.

8.6 Wiring Specification

To standardize the wiring specifications for the Soluna HV Pack(L-E) Series, the following requirements must be met for connecting wires:

Battery Wire	Communication Cable
It is recommended to use 8AWG (10mm ²) of conductor with double insulation	It is recommended to use Standard communication cable with shielding function.

8.7 Wi-Fi module connection

Single battery unit

Wi-Fi module should be connected to the CAN2 port of battery with Wi-Fi cable, Please find the following position of Wi-Fi module for details.



The battery units are connected in parallel

User only need to install 1 unit Wi-Fi module on the HV parallel box, Please find the following position of Wi-Fi module for details.



Remark:

- 1) User can find the user manual of Wi-Fi module in the Wi-Fi packing box
- 2) Please take the necessary precautions to securely ground the box according to the recommended guidelines and standards for installation.
- 3) For the wiring of the parallel connection box, please refer to the user manual for detailed instructions.

9 Electrical connection

9.1 Single battery unit

- Communication cable
- Battery positive pole
- Battery negative pole

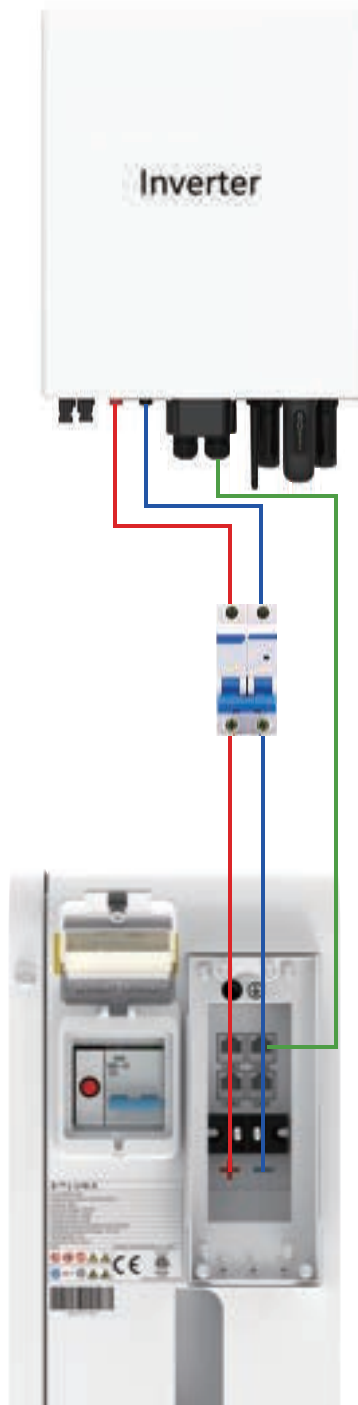

America Parallel Box



European parallel box

9.2 The battery units are connected in parallel

a) 2-4units in parallel connection

- Communication cable
- Battery positive pole
- Battery negative pole

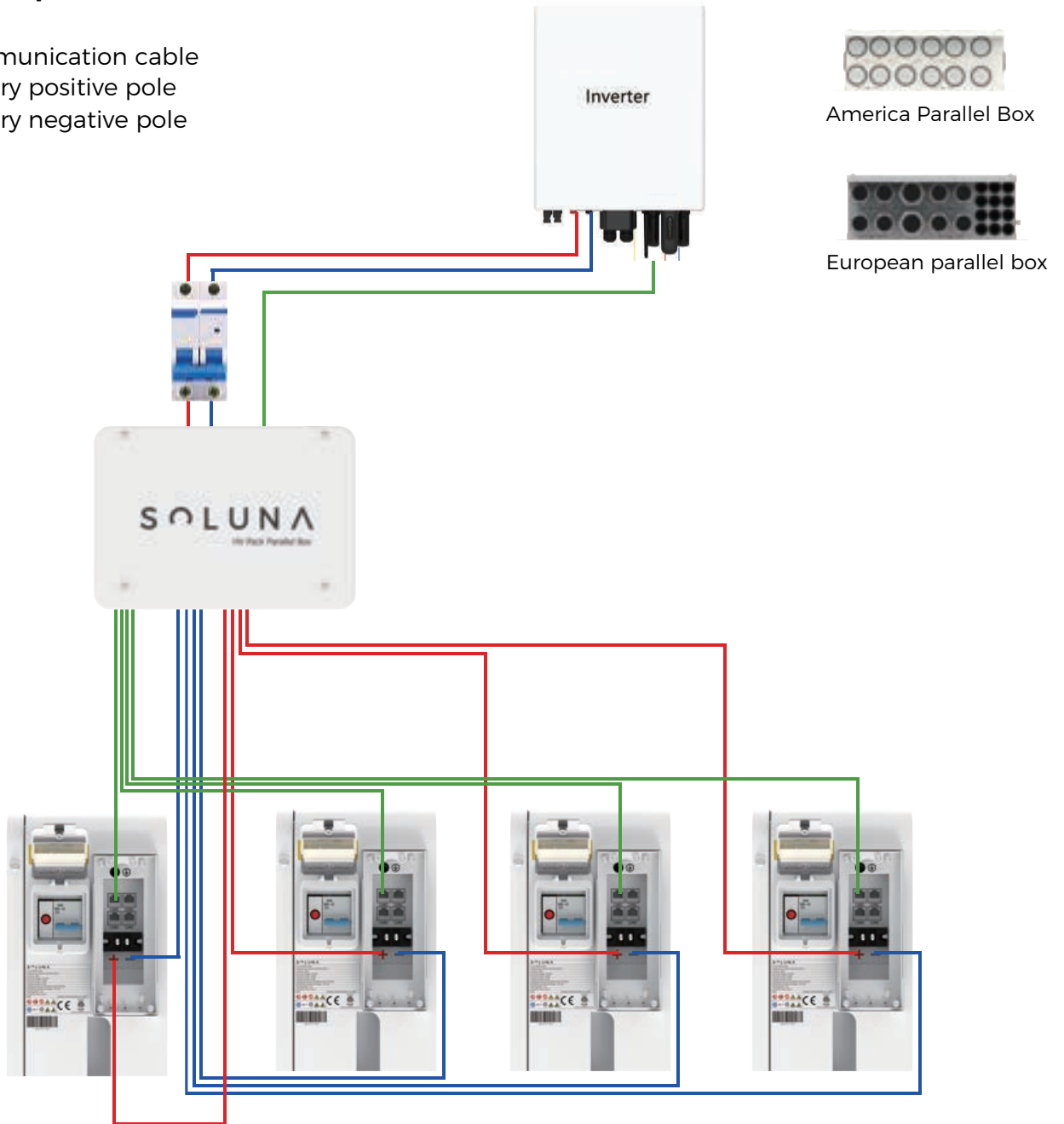

Remark:

The "1&2" on the dial resistance of the HV Pack Parallel Box should be turned to the "ON" position, please find the above drawing in red cycle

B) 10 units in parallel connection

- Communication cable
- Battery positive pole
- Battery negative pole

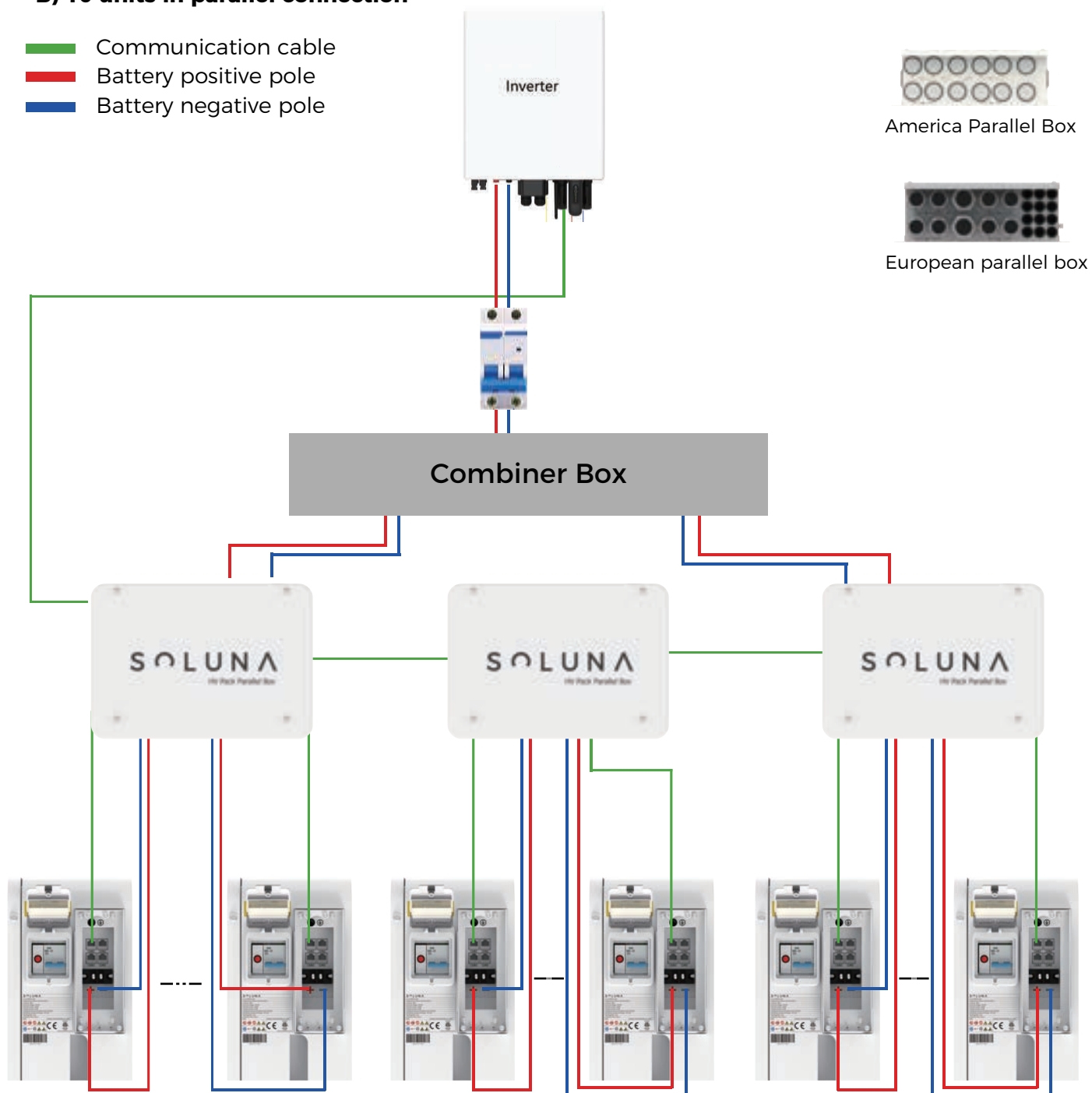

Remark:

- The "1&2" on the dial resistance of the HV Pack Parallel Box should be turned to the "ON" position, please find the above drawing in red cycle.
- Please connect the parallel box during installation by following the instructions provided in the user manual for high-voltage parallel box.
- Refer to the parallel box manual for wiring.

10 How to operate Soluna 10K Pack HV

Step: please see below information for details.

- Connect the inverter and battery module with communication & battery cable
- Turn on the breaker, the breaker is on the right side of Soluna 10K Pack HV (L-E).

Please see below figure for details.

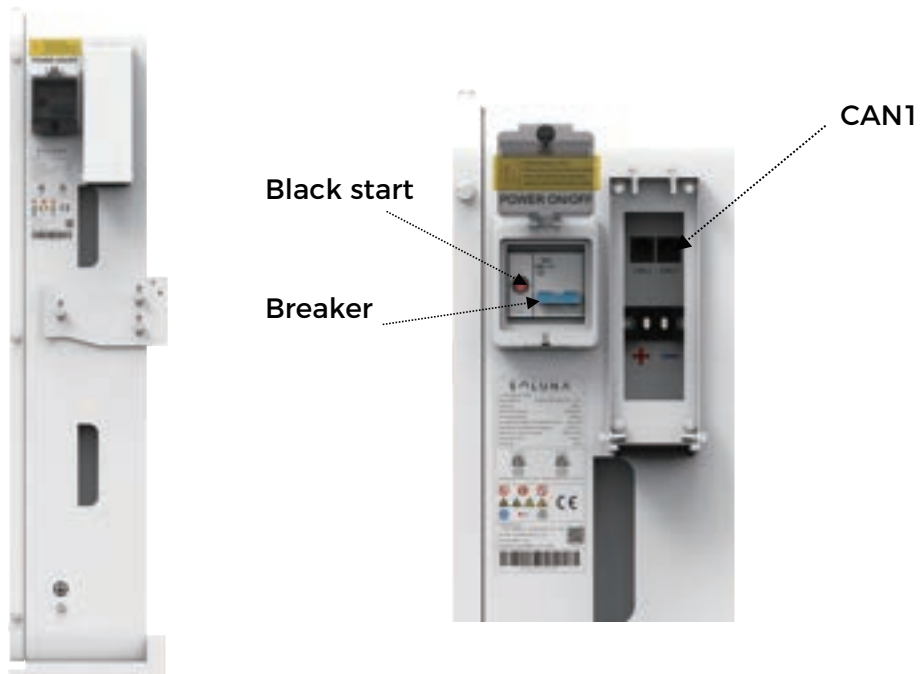





Remark:

- CAN1 is connected to inverter for communication.
- Soluna 10K Pack HV can only operate after receiving the inverter's communication instructions.
- After the system is powered on, the user needs to select the battery communication protocol on the inverter, so that the system can run normally.
- In pure off-grid case when the first installation is completed, if there is no PV power, long press the battery black start switch to start the system.

11 LED indicator description

Please find the following table for details.

Item	Color	Description
1	 Red	Battery is on black start mode. To active battery black start mode, please press the black start button and hold for 10 seconds. Battery can power the inverter and active the communication with inverter if there is no power grid or solar panels.
2	 Purple	Battery has lost communication with inverter for over 5 minutes.
3	 Yellow	Battery is on protection model. The battery reached to the 3rd level protection alarm such as over voltage, under voltage, over temperature, low temperature, etc.
4	 White	Battery is on working model. If there are more than one battery in parallel connection, it means this battery is the master battery on working model.
5	 Green	Battery is on working model as a slave battery in parallel connection.

12 Trouble shooting guideline

Please find the following table for details.

Led Indicator	Possible root cause	How to target the root cause	Solution
Led is purple	Compatible inverter firmware is not the latest reversion.	Please check the inverter APP or LCD/LED for firmware reversion.	Update inverter's firmware.
	Battery firmware is not the latest reversion.	Please check the Soluna smart energy cloud for firmware reversion.	Update battery's firmware.
	Installer didn't choose Soluna battery correctly on inverter APP or LCD/LED.	Please check if the selection of battery is correct or not.	Reselect Soluna battery on inverter.
	Communication cable is loose or not correct.	Please check the communication cable status.	Replug or change the communication cable.
	Inverter hardware fault	Please change another inverter to try.	Contact with inverter manufacture.
	Battery hardware fault	If you checked all the items above and still can't target the reason, please contact with Soluna. Or change the battery.	Contact with Soluna for further action.

N/A(Battery can't be charged or discharged)	Inverter setting incorrect such as disable the charging or discharging and time setting, etc.	Check the inverter setting.	Change the inverter setting.
	Inverter can't read Soluna battery type correctly.	Please check the battery type of product and product name shown in inverter side.	Contact with Inverter manufacturer or Soluna for further action.
	Inverter hardware fault.	Please change another inverter to try.	Contact with Inverter manufacturer.
	Battery hardware fault.	Please change another battery to try.	Contact with Soluna for further action.
Led is off or yellow	Off-grid installation, battery can't be charged for over 2 weeks due to no production of PV system(raining season, snow season, or PV system fault).	Check the battery voltage through the reserved service port. If the 15K HV voltage is less than 300V, 10K HV voltage is less than 210V, 6K HV voltage is less than 120V, please turn off the battery and contact with Soluna.	Contact with Soluna for further action.
	Customer didn't turn off the battery for over 2 weeks in the scenario such as: A. Installation is not finished. B. System failure, not running.	Check the battery voltage through the reserved service port. If the 15K HV voltage is less than 300V, 10K HV voltage is less than 210V, 6K HV voltage is less than 120V, please turn off the battery and contact with Soluna.	Contact with Soluna for further action.
	The battery was stocked for over 2 years without charging.	Check the battery voltage through the reserved service port. If the 15K HV voltage is less than 300V, 10K HV voltage is less than 210V, 6K HV voltage is less than 120V, please turn off the battery and contact with Soluna.	Contact with Soluna for further action.

N/A	Battery firmware is not updated to latest.	Please check the Soluna smart energy cloud for battery firmware reversion.	Updating the battery firmware to the latest.
Master battery is white, but not all slaver battery are green	Battery firmware is not updated to latest.	Please check the Soluna smart energy cloud for battery firmware reversion.	Updating the battery firmware to the latest.
	Battery power cable is loose, or not correct connected.	Check the battery power cable.	Fasten the power cable.
	Communication terminal resistor is not dailed or not dailed correctly.	Check the parallel box for the resistor dailling.	Dail the terminal resistor according to manual or SOP.
	Battery firmware is not the latest.	Please check the Soluna smart energy cloud for battery firmware reversion.	Upgrade the firmware to the latest.
N/A	The Wifi network is not compatible	Check the ender user network type.	Please choose only 2.4G wifi mode.
	Connecting fail	APP will remind.	Please read the SOP of wifi setting up.
	System establish failed due to S/N invalid.	APP will remind.	Contact with Soluna for further action.

N/A	Battery reach to 1st level alarm such as battery over voltage.	Please check the Soluna smart energy cloud for battery alarm information.	Please ignore it, this alarm message is only used for inverter strategy. The power of charging/discharging will be reduced.
	Battery reach to 2nd level alarm such as battery over voltage.	Please check the Soluna smart energy cloud for battery alarm information.	Please ignore it, this alarm message is only used for inverter strategy. The power of charging/Discharging will be limited.
Yellow	Battery reach to 3rd level alarm such as battery over voltage.	<p>1) .Please check the inverter LCD/LED or APP for the battery alarm information</p> <p>1) .Please check the Soluna smart energy cloud for battery alarm information.</p>	Battery will shut down, please contact with Soluna for further action.

Damage to the battery system due to under voltages

- Charge the over-discharged system within seven days when the temperature is above 25°C
- Charge the over-discharged system within fifteen days when the temperature is below 25°C.
- If the battery system doesn't start up, please contact Soluna local after-sales service within 48 hours. Otherwise, the battery could be permanently damaged.

13 Depth of Discharge (DoD) setting of inverter

To make sure the battery working smoothly, we recommend the DOD setting of inverter as follows.

On-Grid DOD:80%

Off-Grid DOD:70%

Power dispatching mode DoD:70%

In energy storage systems, reducing the depth of discharge (DOD) of lithium batteries is aimed at ****improving system economics, extending battery life, enhancing safety, and optimizing performance****. Below are the specific reasons:

1. Extending Battery Life

- The cycle life of lithium batteries is closely related to the depth of discharge. Deep discharge (e.g., 80%-100% DOD) accelerates battery aging, leading to faster capacity degradation.
- Reducing DOD (e.g., controlling it between 20%-80%) can significantly extend the battery's cycle life, thereby lowering long-term maintenance and replacement costs for the energy storage system.

2. Improving System Economics

- Batteries account for a significant portion of the cost in energy storage systems. Extending battery life means reducing the frequency of battery replacements and lowering the total lifecycle cost.
- Although reducing DOD decreases the available energy per cycle, the overall energy throughput (total charge-discharge capacity) may increase by extending battery life, there by improving economic efficiency.

3. Enhancing Safety

- Deep discharge increases the risk of over-discharge, causing the battery voltage to drop too low, which may lead to irreversible chemical damage (e.g., dissolution of the copper current collector in the anode).
- Reducing DOD can prevent over-discharge, minimize safety risks such as thermal runaway, and ensure stable operation of the energy storage system.

If you have any questions, feedback, or need assistance, please feel free to reach out to us. We are here to help!

Soluna (Shanghai) Co.,Ltd

Add: No.3492 Jinqian Road, Shanghai, China 201406

Tel: +86-21-57475835

Email: sales@solunabattery.com

Web: www.solunabattery.com

Social media: <https://www.linkedin.com/company/solunabattery>