

Install an IQ Load Controller with the Enphase Storage System

The Enphase IQ Load Controller, when used in conjunction with the IQ System Controller, enables control of up to two dedicated loads or shedding of up to two solar circuits when operating in an off-grid mode with the Enphase Energy System. To install the IQ Load Controller, read and follow all warnings and instructions in this guide. Safety warnings are listed on the back of this guide. If you do not fully understand any of the concepts, terminology, or hazards outlined in these instructions, refer installation to a qualified electrician or installer. These instructions are not meant to be a complete explanation of a renewable energy system. All installations must comply with national and local electrical codes. Professional installation is recommended.

The IQ Load Controller is an outdoor-rated, NRTL-certified NEMA type 4X enclosure with a DIN rail that contains two contactors, a power supply, wire for control connections and other wiring accessories. Use the IQ Load Controller for controlling dedicated, heavy, split-phase loads or for solar circuit shedding when solar power exceeds allowed solar to storage ratios. Heavy loads are those that exceed the power or surge capabilities of your energy management system. The IQ Load Controller supports control of 2 split-phase loads i.e., loads wired L1-L2 and running at 240V nominal AC voltage or 4 loads running at 120V nominal AC voltage.

IMPORTANT: The Enphase IQ Load Controller is an accessory for the IQ System Controller. The IQ System Controller is required to control loads or shed excess solar circuits using the IQ Load Controller.

For more details, refer to the load control technical brief available at: <https://enphase.com/installers/storage/load-control>

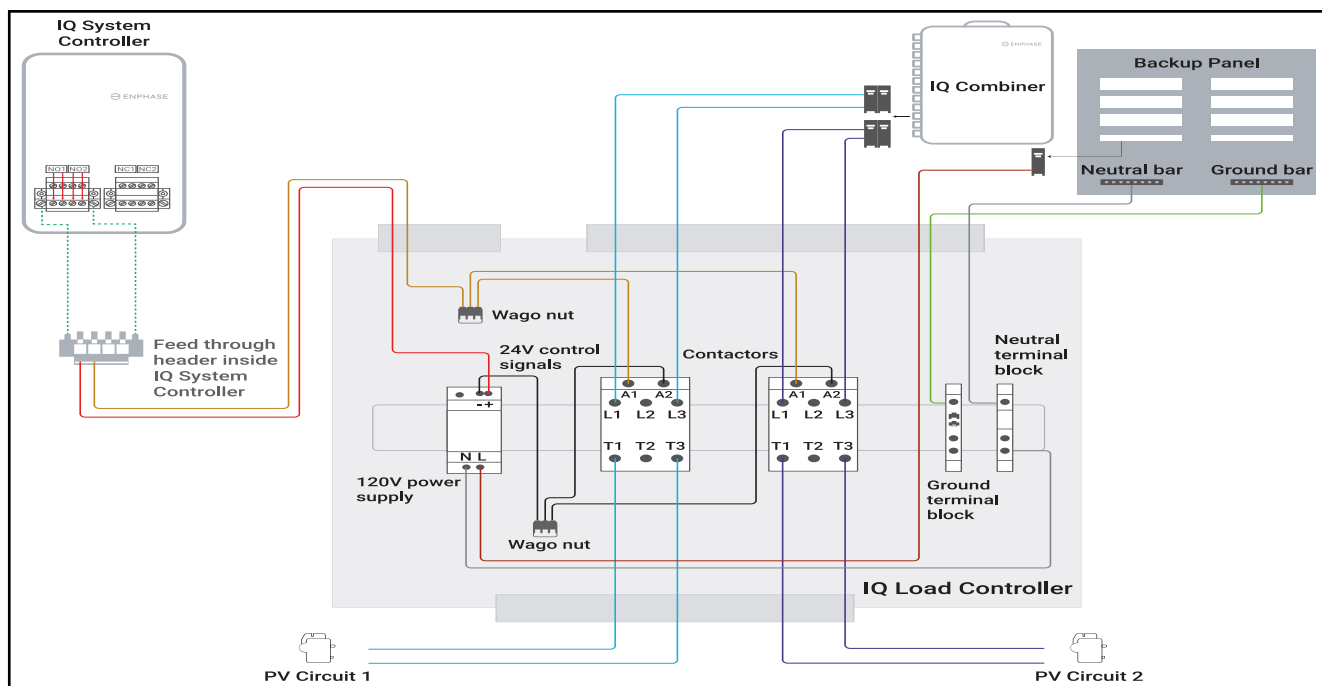
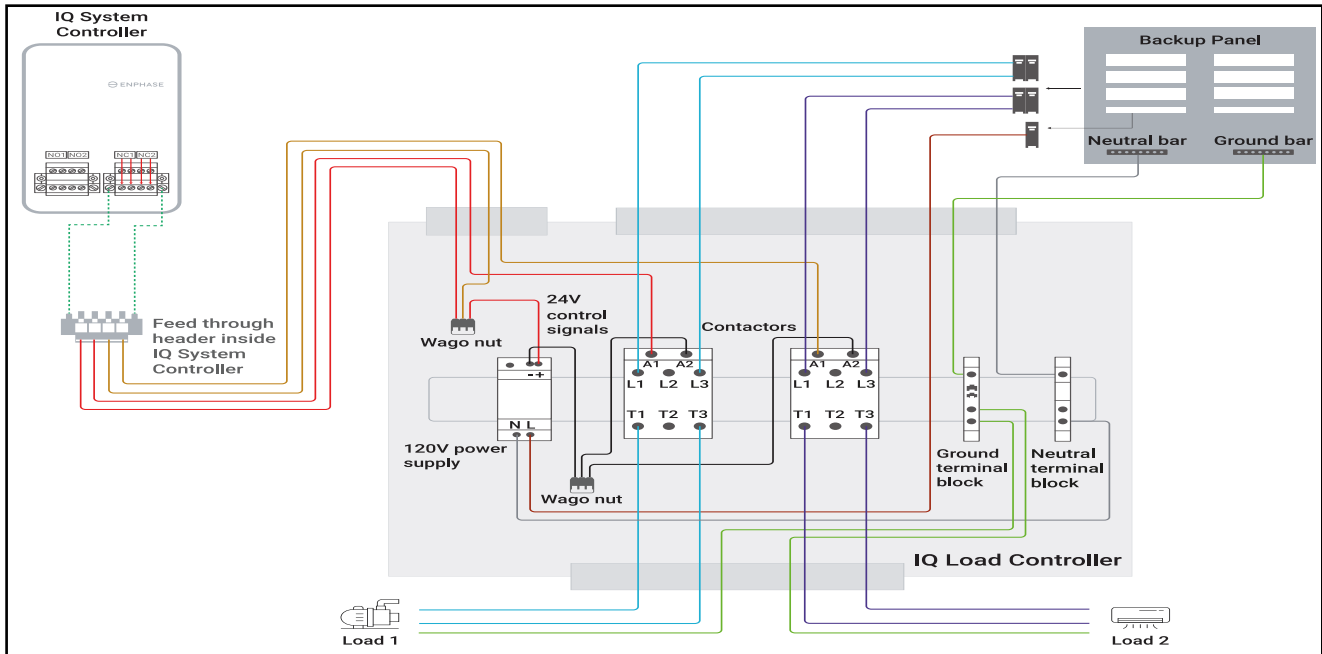

PREPARATION

- A) Download the Enphase Installer App version 3.X mobile app and open it to log on to your Enphase App account. You will require this application to commission and program IQ System Controller to work with the load control box. To download, go to enphase.com/toolkit.
- B) If you have ordered the IQ load control box, check the package for the following items:

Sr No	Item	Quantity
1	IQ Load Controller Box	1
2	Din Rail	1
3	36A Contactor	2
4	Power Supply	1
5	Ground Terminal Block	1
6	Neutral Terminal Block	1
7	Din Rail End Clips	2
8	Splicing Connectors(Wago Nut)	2
9	18 AWG wire spool	1
10	Feed Through Headers	1
11	Installation Reference Sheet	1

INSTALLATION - PART 1

1 Choose a location for installing the IQ Load Controller

- A) Install the IQ Load Controller in a readily accessible location. Install it as close to the IQ System Controller as feasible.
- B) Mount the IQ Load Controller on a vertical surface.
- C) The product comes with the negative of the power supply connected to the A2 terminal of the 2 contactors via a wago nut. Ensure this wiring is firmly in place.
- D) We recommend a maximum diameter of 1.5 inches for any conduit installed on the enclosure. Hubs must be connected to the conduit before being connected to the enclosure. Conduit used must be watertight.
- E) Branch circuit protection is required using either DIVQ Breakers or Class listed fuses. The breakers/fuses must be rated for 45A for the line power terminals connected to the contactor, and 15A for power supply input terminals.

INSTALLATION - PART 2

1 Wiring Instructions

NOTE: Electrical Shock Hazard. This work should be completed by a trained electrician. Ensure all wiring is deenergized prior to installation.

NOTE: The below instructions show the wiring for controlling 2 loads via the IQ System Controller's auxiliary contacts. Each load can be controlled independently. Similar instructions for controlling PV are detailed towards the end of this document.

NOTE: When used for load shedding, Use the IQ Load Controller for controlling dedicated loads only.

NOTE: The contactor is rated for 36A resistive current and 25A Inductive/3HP motor rating.

NOTE: Use AWG, 75° C copper conductors only.

NOTE: We provide a 18AWG 600V TEW wire with the product. If local jurisdictions require a MTW or any other rated wire, please arrange accordingly.

Connection Type	Torque(Nm)	Wire Gauge
Contactor		
Line/load power terminals	2.5Nm(22 Lb-in)	14-8AWG
Contactor A1/A2 control terminals	1.2Nm(11Lb-in)	18-16AWG
Power Supply		
120V L - N input terminals	0.34Nm(3Lb-in)	14AWG (10A breaker) 14AWG(15A breaker) 12AWG(20A breaker)
24V V+ / V- output terminals	0.497Nm(4.46Lb-in)	18-16AWG
Ground bar terminal block	1.5Nm(13.3Lb-in)	24-6AWG
Neutral terminal block	1.5Nm(13.3Lb-in)	24-6AWG

	EP-NA-LK02-040	Voltage Rating	Current Rating	OCPP
Load/PV circuits	Dedicated load circuits	240/120VAC, 60Hz	36A Resistive, 25A Inductive/3HP	45A
	Branch circuit supplying more than one load	240/120VAC, 60Hz	32A Resistive, 25A Inductive/3HP	40A
	PV circuits	240VAC, 60Hz	32A	40A
Power supply	DC Power supply input	120VAC, 60Hz	12A	15A
	DC Power supply output	24VDC	1.5A	N/A

A) Wire the Control/Coil Terminals of the Contactors

Each feed through header has 4 terminal blocks.

For eaton contactors, A1, A2 are at the left of the contactor, whereas for ABB, they are at the top.

- 1) Connect the wire from A1 of the left contactor #1 to Terminal 2 of the feed through header.
- 2) Similarly connect the wire from A1 of the right contactor #2 to the Terminal 4 of the feed through header.

Low voltage contactor wiring diagram

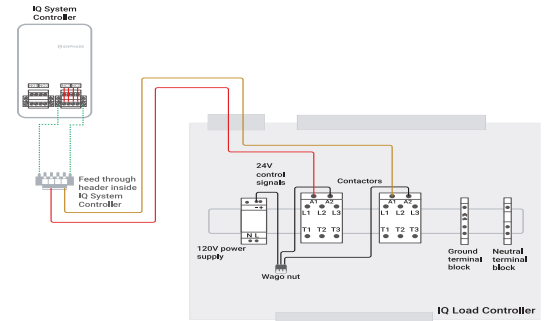

B) Complete the Power Supply connections

Refer the power supply wiring in the diagram provided on the first page.

- 1) Connect the positive output of the power supply to Terminal 1 and Terminal 3 of the feed through header via a wago nut.
- 2) Ensure the negative output of the power supply has been connected to the A2 of the two contactors via a wago nut.
- 3) Connect the neutral input of the power supply to the neutral terminal block. Connect the neutral terminal block to the neutral bar on the backed up panel.
- 4) Connect the line input of the power supply to a single pole breaker on the backed up panel.

NOTE: For wiring connections to the IQ System Controller, a 18-16AWG wire is required.

NOTE: The power supply has a overload protection at 160% of the rated power.

C) Connect the feed through headers to IQ System Controller

- 1) Tighten the screws on the top (torque 0.22Nm to 0.25Nm) to secure the wires.
- 2) Connect the feed through header to the correct IQ System Controller aux contact terminals. We recommend using NO contacts for PV shedding and NC for load shedding.

1. Insert wires here

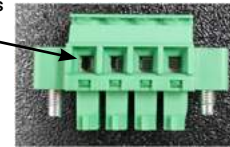

2. Tighten these screws to hold the feed through header in place once its inserted into the auxiliary contact terminals.



D) Test the Low Voltage Connections

NOTE: For the purpose of the low voltage wiring connections test described next, please ensure you connect the feed-through headers to the NC contacts. Post completion of this test, for the actual system commissioning, you may choose either NC or NO ports available on the IQ System Controller.

At this point, you have completed all the low voltage wiring connections. Conduct the following test to ensure everything has been correctly wired so far. Please make sure you perform this test before you complete the wiring of the AC lines and commission the system via Enphase Installer App.

Test	Expected Observation	Possible cause for not seeing the expected observation
Close the sub panel breaker to which the power supply is connected.	The armature of the contactor is closed and the circuit is complete.	Check the auxiliary contact connections to make sure each terminal is correctly wired to the control power supply output and the coil of the intended contactor.
Test the line and neutral wires connected to the power supply	Voltage readings should be 120V. LED will illuminate blue when 120V is applied.	Incorrect wiring to the backup panel neutral bar and single pole breaker
Observe the voltage between the A1 and A2 terminals of the contactor	Voltage reading should be 24V	Check the connections to the IQ System Controller dry contact via the feed through headers. Also, check the conductors are fully seeded in the wago nut.

E) Connect the AC lines of the Contactors

⚠ WARNING! Deenergize all power wiring to the power supply and contactors

Once the above test has successfully been performed, complete the circuit by following the below steps

- 1) Connect the 2 wires from L1 & L3 of the contactor(s) to a double pole breaker on the backup panel.
- 2) Connect the 2 wires from T1 & T3 of the contactors to the loads that are to be controlled.

NOTE: Ensure that there is uniform current on the 2 outer poles of the contactor. If a contactor is being used to shed 2 single pole 120V loads, do ensure that both loads have similar power requirements.

NOTE: The AC output is not bonded to ground.

NOTE: The IQ Load Controller can also be used for shedding 4 loads running at 120Vac. If being used for such a use case it is important to ensure that the individual loads are connected on the outer poles of the contactors. Whenever possible, try to balance the current on the 2 poles of a contactor. To do this, connect the 2 loads with similar current requirements on the same contactor. This will prevent unequal wearing of the 2 poles of the contactors, thus ensuring a longer service life for the contactor.

Contactor wiring diagram

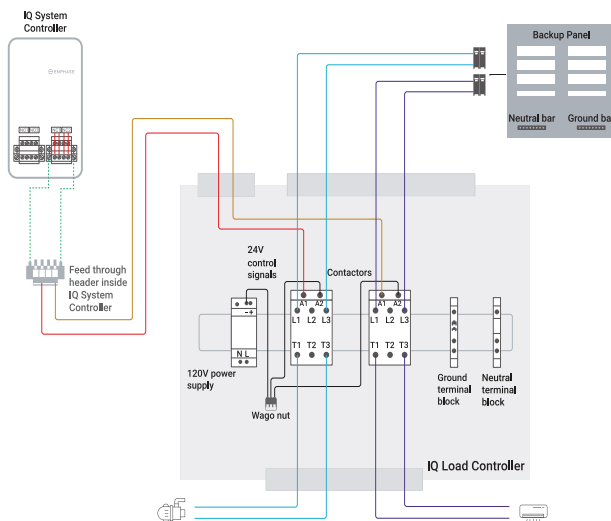

Perform the following tests to ensure that the AC wiring is connected correctly. The below mentioned tests are assuming the kit is used for load control. Similar tests can be performed for PV controlling kits too.

Test	Expected Observation	What does the observation mean?	Possible cause for not seeing the expected observation
1. Open the breaker connected to the power supply input. 2. Use voltmeter to test the terminals of the contactor. 3. Close the load breaker.	The supply side of the contactor should have 240V, load side should have 0V	Contactors has been correctly configured	Check L1, L2 line connections.
Close the breaker connected to the power supply input	You should see 240Vac on both sides. Armature pin is sucked in.	Load is successfully connected and operating.	Ensure power supply wiring is as described in step B

NOTE: If only using 1 contactor, you may disconnect the 24V control wiring connected at the A1 terminal of the 2nd contactor. Remove unused wiring from Wago connector.

F) Commissioning Auxiliary Contacts via Installer App

- 1) Please refer the load control technical brief for details on using the Installer App for commissioning the auxiliary contacts (available at: <https://enphase.com/installers/storage/load-control>).

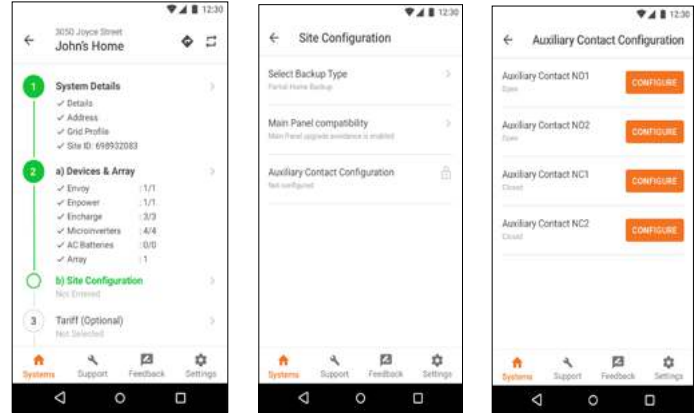

G) Grounding the kit

NOTE: These grounding instructions are common to both use cases, load shedding as well as PV shedding.

NOTE: The conductor used to connect to the Ground Terminal Block must be at least 10 AWG

NOTE: If the conduit fittings require a GND connection, the GND conductor used shall be 10 AWG and must originate from the GND splice.

NOTE: The Terminals on the GND Terminal block are suitable for the connection of one conductor only.

The kit comes with a ground terminal block. We recommend having as many ground wires from the backup panel to the ground terminal block as the number of live wires flowing in. If 2 loads are being shed, then 3 ground wires must be brought in from the backup panel ground bar (2 for the load breakers, 1 for the power supply breaker). We also recommend grounding the loads directly. Depending on the jurisdiction in which this installation is being done, you may need to ground the conduits as well.

H) Managing the neutral wiring

According to the NEC code, the neutral wires must also pass through the assembly (in this case, the IQ Load Controller) through which the live wires are passing. The kit comes with a pre-mounted neutral terminal block that can be used for landing the neutral wires from the neutral bar on the backup panel and the wires from the loads.

I) Securing the enclosure

The product comes with a zip tie provided in the kit. Please use the same to lock the enclosure. The product does not contain any user serviceable parts. Hence, it is essential to lock the enclosure. The door must only be opened by a qualified personnel for any repair or maintenance.

INSTALLATION - PART 3

1 Testing the IQ Load Controller with the IQ System Controller

Once the complete circuit has been wired, perform the below checks to

A) Validation of Auxiliary contacts using Enphase Installer App

Go to the 'Live Status Screen' in step 7 of system commissioning for validating the auxiliary contact connection. Follow the workflow and check that the system is behaving as expected. For more details, please refer to the technical brief(available at: <https://enphase.com/installers/storage/load-control>).

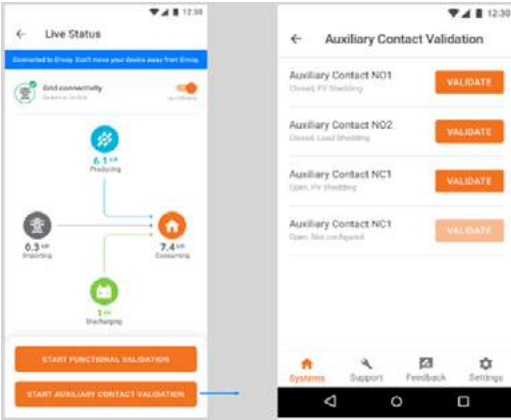

B) Post System Commissioning Steps: Functional Validation

Perform the following tests to ensure that the IQ Load Controller is functioning as intended. The below mentioned tests are assuming the kit is used for load control with basic mode setting. Similar tests can be performed for PV controlling kits too.

1) Use Enphase Installer App to Go Off-Grid:

Go to the 'Live Status' screen. Use the 'Go Off-Grid' toggle switch to get the system off-grid. When you do this, You should hear a sound of the IQ System Controller's Microgrid Interconnect Device (MID) relay opening and see the contactors' contacts opened i.e., pushed up. Use the voltmeter to test the load side voltage and check that it shows a 0V reading. This means that load control feature has been successfully configured. Please note that it can take up to 40-60 seconds for the system to go off-grid and the MID to open.

2) Use Enphase Installer App to Go On-Grid:

On the 'Live Status' screen, toggle back the 'Go Off-Grid' toggle switch to get the system back on-grid. You should see contactors' contacts closed i.e., pushed down. Use a voltmeter to confirm that there is voltage present on the load side (T1 / T3) contacts of the IQ Load Controller.



Wiring Diagram for shedding 2 PV branches via load control

If the IQ Load Controller is to be used for PV shedding, please apply the PV shedding wiring label (provided with this QIG) on top of the load shedding wiring diagram in the label on the inner door of the box.

NOTE: A single contactor can be used for shedding PV branch circuits connected to a 40A over-current protection device with 32A continuous current.

A) Wire the low voltage connections of the Contactors

- 1) Connect the wire from A1 of the 2 contactors together via a wago nut provided to Coil/Control Terminals 2 of the feed through header.
- 2) Ensure the A2 terminal of the 2 contactors is connected to the negative of the power supply via a wago nut. The product comes with this connection pre-wired.

Low voltage contactor wiring diagram for PV shedding

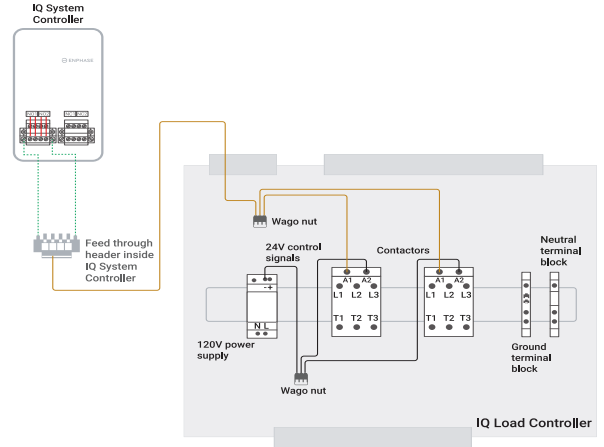

B) Complete the Power Supply connections

Refer the PV shedding wiring diagram on the first page of the document for the power supply wiring.

- 1) Connect the positive output of the power supply to the first terminal of the feed through header via a wago nut.
- 2) Ensure the negative output of the power supply has been connected to the A2 of the 2 contactors via a wago nut.
- 3) Connect the neutral input of the power supply to the neutral neutral terminal block. Connect the neutral block to the neutral bar on the backed up panel.
- 4) Connect the line input of the power supply to a single pole on the back up panel.

C) Connect the feed through headers to IQ System Controller

- 1) Tighten the screws on the top (torque 0.22Nm to 0.25Nm) to secure the wires.
- 2) Connect the feed through header to the correct IQ System Controller aux contact terminals.



1. Insert wires here



2. Tighten these screws to hold the feed through header in place once its inserted into the auxiliary contact terminals

D) Connect the AC lines of the Contactors

Once the above test has successfully been performed, complete the circuit by following the below steps:

- 1) Connect the 2 wires from L1 & L3 of the contactors to a double pole breaker on the combiner.
- 2) Connect the 2 wires from T1 & T3 of the contactor to the PV.

Contactor wiring diagram for PV shedding

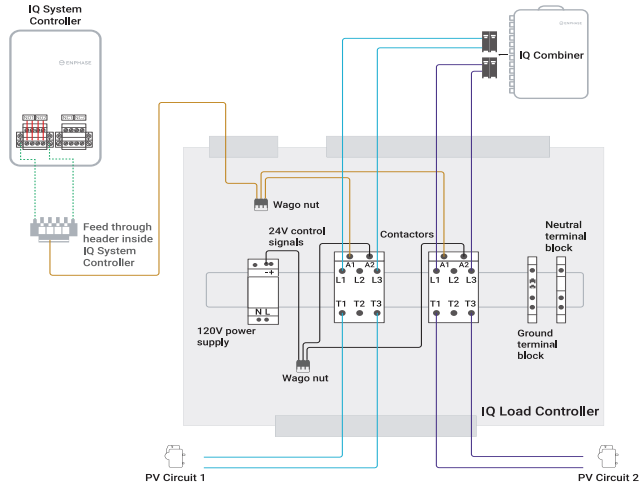

RMA instructions for the load control box

- A) Enphase Store provides an option for a 30 days no questions asked return. This policy is applicable for the load control box as well. Reach out to Enphase Support [at <https://support.enphase.com/s/contact-us>] within this time to return the load control box.
- B) Enphase will provide a standard warranty of 5 years from the date of purchase only on the following items present in the box:
 - o Power Supply
 - o Contactors
 - o Box internal din rail
 No warranty is applicable on any other items present in the box.
- C) If you are seeking a replacement for a failed part within the warranty period, please write to Enphase Support [at <https://support.enphase.com/s/contact-us>]. Once your request has been approved, you will receive a mail with a digital copy of a FedEx label. You can place the failed part in any standard box(or bag), apply the FedEx label provided and drop it at the nearest FedEx facility or ask FedEx for a site pickup.
- D) Upon receipt of the defective part, Enphase will ship a new replacement part to the provided address.

SAFETY

IMPORTANT SAFETY INSTRUCTIONS. SAVE THESE INSTRUCTIONS. This guide contains important instructions that you must follow during installation and maintenance of the Enphase IQ Load Controller. Failing to follow any of these instructions may void the warranty (enphase.com/warranty).

Safety and Advisory Symbols

	DANGER: This indicates a hazardous situation, which if not avoided, will result in death or serious injury.
	WARNING: This indicates a situation where failure to follow instructions may be a safety hazard or cause equipment malfunction. Use extreme caution and follow instructions carefully.
	NOTE: This indicates information particularly important for optimal system operation. Follow instructions carefully.

Safety Instructions

	DANGER: Risk of electric shock. Do not use Enphase equipment in a manner not specified by the manufacturer. Doing so may cause death or injury to persons, or damage to equipment.
	DANGER: Risk of electric shock. Be aware that installation of this equipment includes risk of electric shock. Do not install the IQ Load Controller without first removing AC power from the Enphase System.
	DANGER: Risk of electric shock. Risk of fire. Only qualified personnel should troubleshoot, install, or replace the IQ Load Controller.
	DANGER: Risk of electric shock. Improper servicing of the IQ Load Controller or its components may result in a risk of shock, fire or explosion. To reduce these risks, disconnect all wiring before attempting any maintenance or cleaning.
	DANGER: Risk of electric shock. Risk of fire. Ensure that all wiring is correct and that none of the wires are pinched or damaged.
	DANGER: Risk of electric shock. Risk of fire. Do not work alone. Someone should be in the range of your voice or close enough to come to your aid when you work with or near electrical equipment. Remove rings, bracelets, necklaces, watches etc. when working with batteries, photovoltaic modules or other electrical equipment.
	DANGER: Appliances connected to controlled branch circuits can experience unintended starts. Ensure appliances are turned off per manufacturer instructions before servicing.
	DANGER: Product not suitable for Loads that provide emergency/safety functions, medical critical loads, or required emergency egress.
	WARNING: This product is intended for operation in an environment having a temperature range of -25 to 40° C.

Safety Instructions, continued

	WARNING: Before installing or using the IQ Load Controller, read all instructions and cautionary markings in the technical description/guide and on the equipment.
	WARNING: Non-metallic enclosure does not provide bonding between conduit connections. Use grounding type bushings and jumper wires.
	WARNING: Disconnect all sources of supply before servicing.
	NOTE: Perform all wiring in accordance with all applicable local electrical codes, with the Canadian Electrical Code, Part I, and with the National Electrical Code (NEC), ANSI/NFPA 70.
	NOTE: Protection against lightning and resulting voltage surge must be in accordance with local standards.
	NOTE: Using unapproved attachments or accessories could result in damage or injury.
	NOTE: To ensure optimal reliability and to meet warranty requirements, the Enphase IQ Load Controller must be installed according to the instructions in this manual.

Environmental Protection



ELECTRONIC DEVICE: DO NOT THROW AWAY. Waste electrical products should not be disposed of with household waste. Refer to your local codes for disposal requirements.