

Ultra

Sloped Roof Mount



FEATURES

- Low profile design saves cost and looks great
- Minimal roof loading (typically under 4psf)
- Attachments for most roof types
- Compatible with Talon roof attachments

ADVANTAGES

- Integrated bonding
- Rail levelling up to 2" on mounting feet
- Trim kits and rodent guards available
- Watertight attachments

The Fast-Rack Ultra rail system is designed for rapid installation of PV arrays on sloped roofs. Standard Fast-Rack features include easy rail leveling, self sealing roof bolts, and integrated bonding. The system was designed to provide Canadians with a cost effective and elegant solution. The Fast-Rack Ultra is fully engineered and CSA certified to meet the highest standards.



MADE IN CANADA



ULTRA — SLOPED ROOF MOUNT

The Fast-Rack Ultra is a complete rail-based mounting system for sloped roofs. The full kit includes rails, mid and end clamps, L-feet, splices, bonding straps and ground lugs.

The Ultra is compatible with the following mounting options:

- Talon (rafterless)
- Lag Screw
- S-5! Clamp

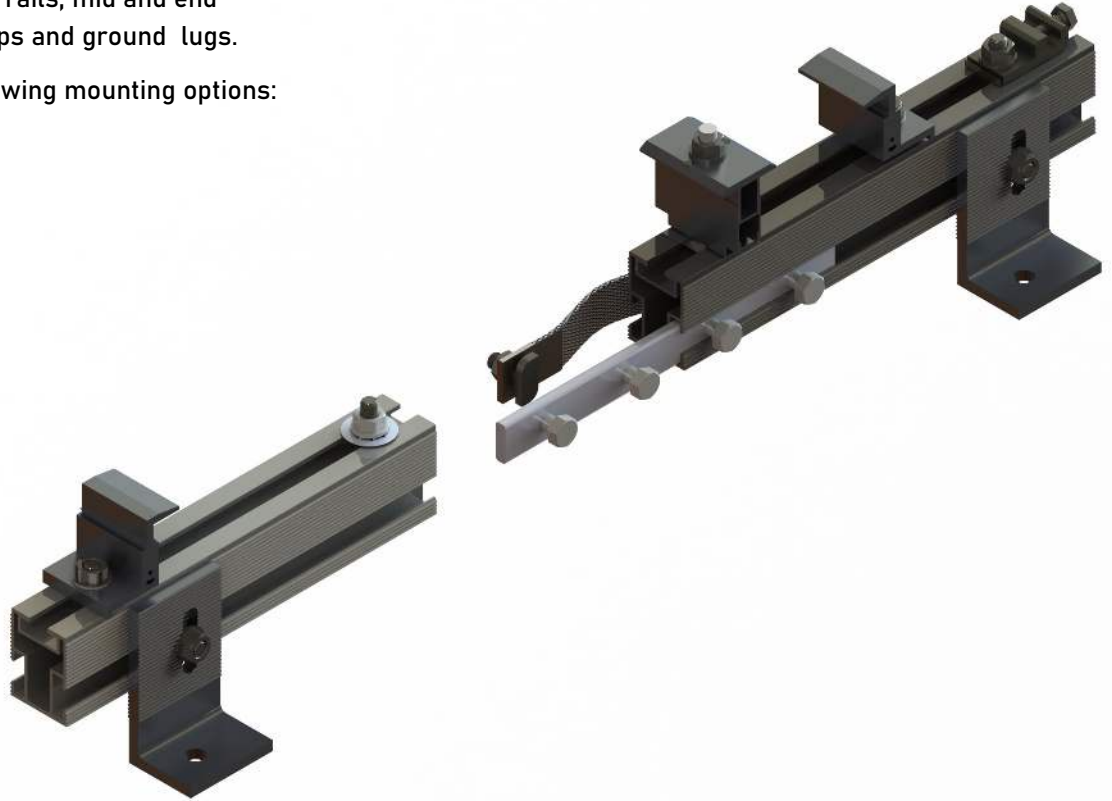

Durable: Every component has been tested to ensure quality, even in Canada's most extreme environments



Bankable: Fast installations and low cost solutions keep your projects on track.



Protected: Every Fast-Rack product is covered by our standard 10-year warranty.



Specifications	
Configuration	Portrait or Landscape
Module Mounting	Top Clamped
Roof Type Compatibility	Shingle, Standing Seam, Corrugated Steel *
Attachments	Lag Screw, Talon, Steel Roof Clamp
Waterproofing	Flashing System
Material	Aluminum
Bonding	Integrated
Certifications	UL-2703-1st Ed., TIL No. A-40

**talk to your dealer if you require a unique solution*

Design and specifications are subject to change without notice. Fast-Rack is a registered trademark™. All other trademarks are property of their respective owners. Contact Fast-Rack to find a dealer near you. Made in Canada with domestic and imported parts.



www.fast-rack.ca • +1 866-437-5529