

## FR-Elite - Installation Manual

Fixed Ground Mount

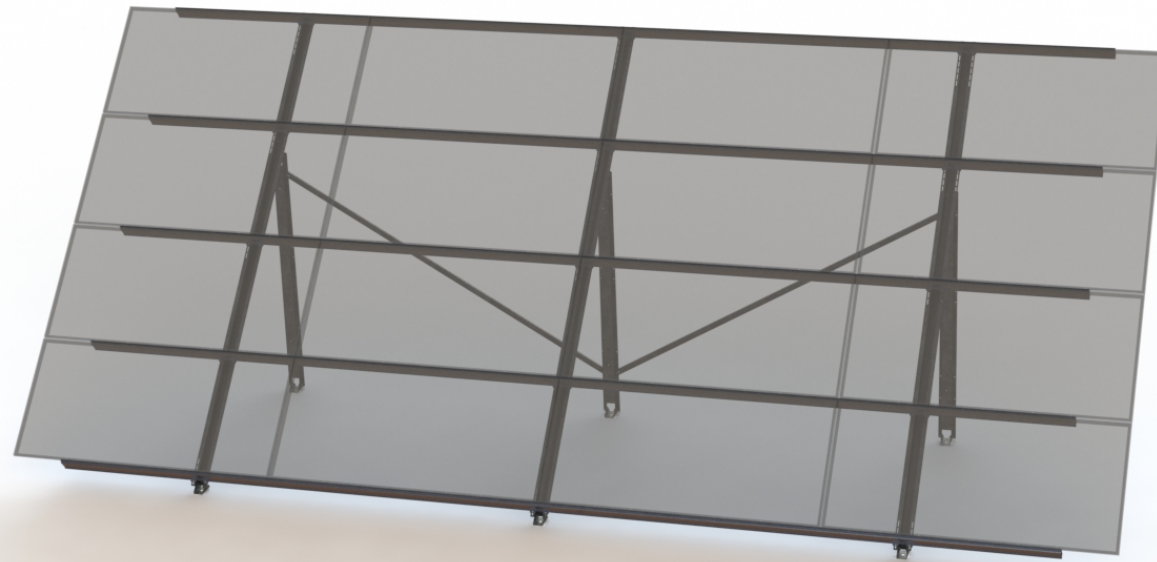

Install Solar Faster

[www.fast-rack.ca](http://www.fast-rack.ca)



Section	Pg
1.0 Using this Manual	1
2.0 Safety	2
3.0 Scope of Delivery	3
4.0 Base Connections	4
4.1 Base Spacing	5
4.2 Angle Selection	6
5.0 Preparing to Install the Frames	7
5.1 Installing the Cross Brace	8
5.2 Dual Cross Brace	9
6.0 Preparing to Install the Rails	10
6.1 Rail Configurations	11
6.2 Installing the Rails	12
6.3 Installing the Rail Splice	13
7.0 Preparing to Install the PV Modules	14
7.1 Installing the PV Modules	15
8.0 Bond Path	16
9.0 Cable Management	17
10.0 Inverter Mount	18
10.1 MLPE Mount	19
11.0 Inspection & Maintenance	20
12.0 Design Limitations	21



## Introduction

This manual is an illustrated guide on how to install the FR-Elite system. It is meant to cover each individual step of the assembly process. Throughout the guide, references will be called to the parts list in order to assist in easily identifying the items required for a specific section. The guide is broken into several sections, each covering the milestone assembly steps, with sub assembly steps in-between where necessary. Each assembly step will include an illustrated list of hardware to be used during that assembly process. Where specified, some assembly sections include a preparation process. It is necessary to follow these preparations in order for the installation to continue smoothly, with no need for back tracking.

Throughout the guide there are reference markings for warnings, and recommendations, identified by these symbols:



Be sure to look for and read these markings. They will provide information such as guidelines to prevent damage to equipment, safety measures to prevent serious injury or bodily harm, and advice on how to make the assembly quicker.

## Liability

The installer and/or contractor or developer of each project shall be responsible and liable for safe and proper installation of each system, and also to initiate, maintain and supervise all safety programs and precautions for each project and project site, and to provide all required protection to prevent damage, injury, loss or death to any or all persons, property and work present or located on the project site.

ChargeSolar™ does not install any portion of its mounting systems and therefore will not have, and hereby specifically disclaims, any duty or responsibility for safe and proper installation of any mounting system or jobsite safety as to any jobsite where installation of any of its mounting systems occurs. Please follow the drawings and instructions, and report any issues or discrepancies to ChargeSolar™.

## Compliance

The Fast-Rack photovoltaic bonding components meet the requirements of CSA TIL No. A-40 and are individually certified to UL Standard 2703 and ETL listed to UL Standard 467.





## Personal Safety

Prior to starting the installation, it is important to identify all potential hazards and implement a safety plan denoting how to deal with these hazards.

Examples of some potential personal hazards which may be encountered during an installation are:

- Fall Hazards – Ensure compliance with OSHA regulations for working at height. Use fall protection, or fall prevention equipment and practices as necessary.
- Electrical Hazards – Observe the location of overhead and underground conductors/electrical equipment. When possible disconnect/lockout circuits in the work area.
- Lifting Hazards – Use proper lifting techniques to prevent work place injuries when moving components on the ground and lifting between the ground and array location.
- Environmental Hazards – Rain, snow, wind, sun and heat. All of these have the potential to injure personnel and property if not properly prepared for.

Once the hazards specific to the installation have been identified, it is critical to devise a plan should a workplace accident occur. Some things to have prepared and discussed prior to start of work are:

- Location of nearest hospital, emergency phone number
- Trained and certified on-site first-aid attendant and location of first-aid kit
- Devise method for extracting injured personnel
- Communication and awareness of potential hazards
- Trained and certified fall protection training for all personnel working at height

Training courses for Fall Protection Awareness and Occupational First Aid can be found in most municipalities.

## Site Safety

Evaluate and identify potential safety hazards and injuries that could occur on the job site. This includes specific work situations and understanding the potential injuries from the identified hazards. Maintaining safety policies and general jobsite safety practices goes a long way to ensuring a smooth and safe install.

Ground-mounted installations often involve the use of heavy equipment for moving materials, grading or clearing land and installing foundations. Ensure machines are being used properly by trained professionals and all workers are familiar with the safety risks of working on a site that uses heavy equipment.

To mitigate the risk of injury and theft on the jobsite, proper fencing, signage and policies should be used. Ensure all construction practices are being implemented as per the Ministry of Labour. Workers, supervisors and employers are all responsible for safety.



### Components

ID	PART	CODE
1	Front Leg	FR-ELT-3000
2	Back Leg	FR-ELT-3001
3	Cross Brace	FR-ELT-3002
4	Foot	FR-ELT-3003
5	Typhoon Rail, 120"	FR-RAIL-2402
6	Typhoon Rail, 170"	FR-RAIL-2405
7	Typhoon Rail Splice	FR-RAIL-1400
8	Typhoon Clip C	FR-CLP-2402
9	Bond Lug	FR-ACC-1400
10	Inverter Mount	FR-ELT-3100
11	MLPE Mount	FR-ELT-1100
12	Module Hardware Kit	FR-ELT-6005
13	Leg Hardware Kit	FR-ELT-6006

### Torque Specifications

SIZE	TORQUE
1/2"	57 lbs.ft
M8	10 lbs.ft

**!** Upon receipt of goods, make sure to check all packaging to ensure delivery of all parts required.

### Hardware

ID	SIZE	TYPE
A	0.50" x 1.25"	Hex Bolt
B	0.50"	Flat Washer
C	0.50"	Hex Nut
D	M8x20mm	Flanged Hex Bolt
E	M8	Flanged Hex Nut
F	M8	Bonding Washer

### Tools

- 3/4" Open end wrench, socket & ratchet
- 13mm Open end wrench, socket & ratchet
- Torque wrench
- Tape measure
- Hand or chop saw
- Wire snips/side cutters

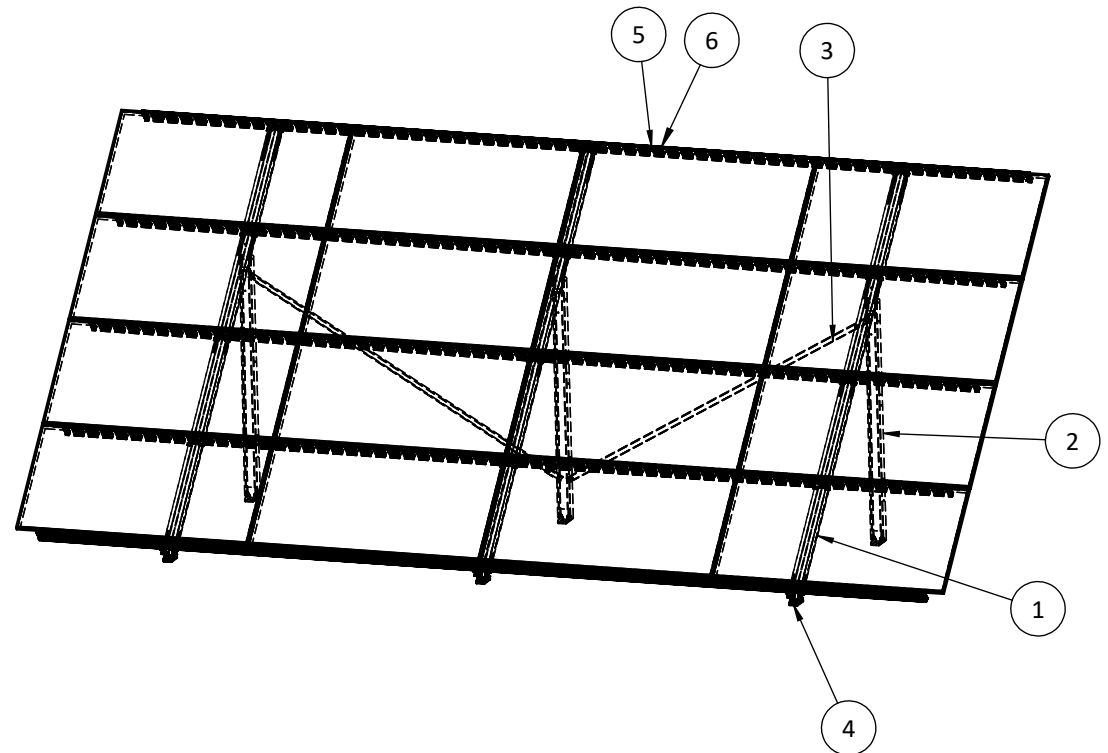



1. The Foot may be fastened to the foundation with a 1" bolt in the center hole, or 2 x 1/2" bolts in the outer holes.
2. Compatible with concrete (piers, pads or precast blocks), piles or custom sub-frame foundation types.
3. Ensure foundations are spaced appropriately for the racking. Take care to align anchors set in concrete foundations.

**⚠** Consult with an engineer before proceeding with the base installation

**i** Anchor bolts must be 1" for center hole, or 1/2" for outer holes. Length, grade, embedment and foundation specifications to be confirmed by an engineer.

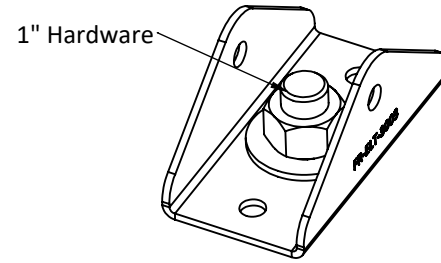

1" Bolted Connection

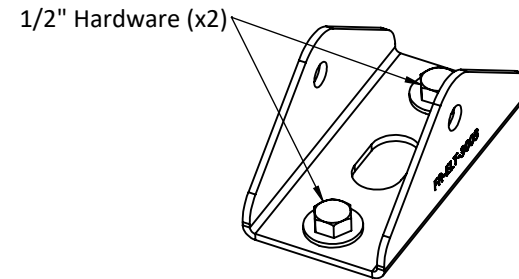
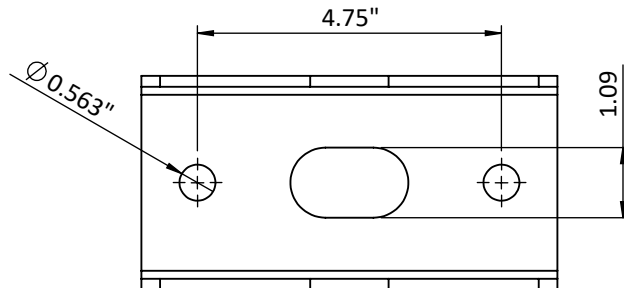

1/2" Bolted Connection



### 4.1 Base Spacing

1. The rack spacing shown is generic and based on a typical system on level ground.
2. Verify array dimensions and determine the allowable shadow angle for your installation.
3. Take into account uneven terrain to limit inter-row shading.

**i** On some sites it may be recommended to increase the inter-row spacing.

**!** Foundation design to be confirmed by a structural or geotechnical engineer.

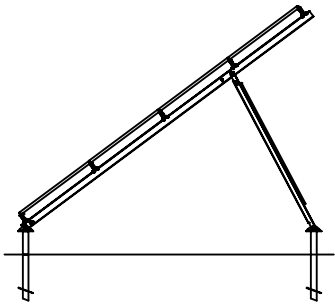

Piles

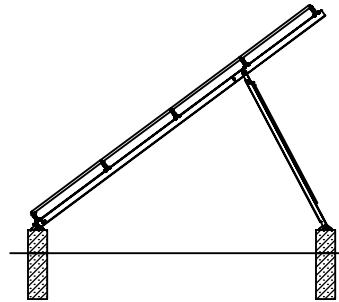

Piers

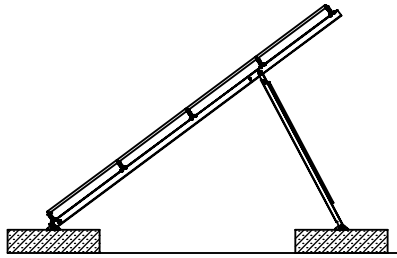

Pads/Blocks

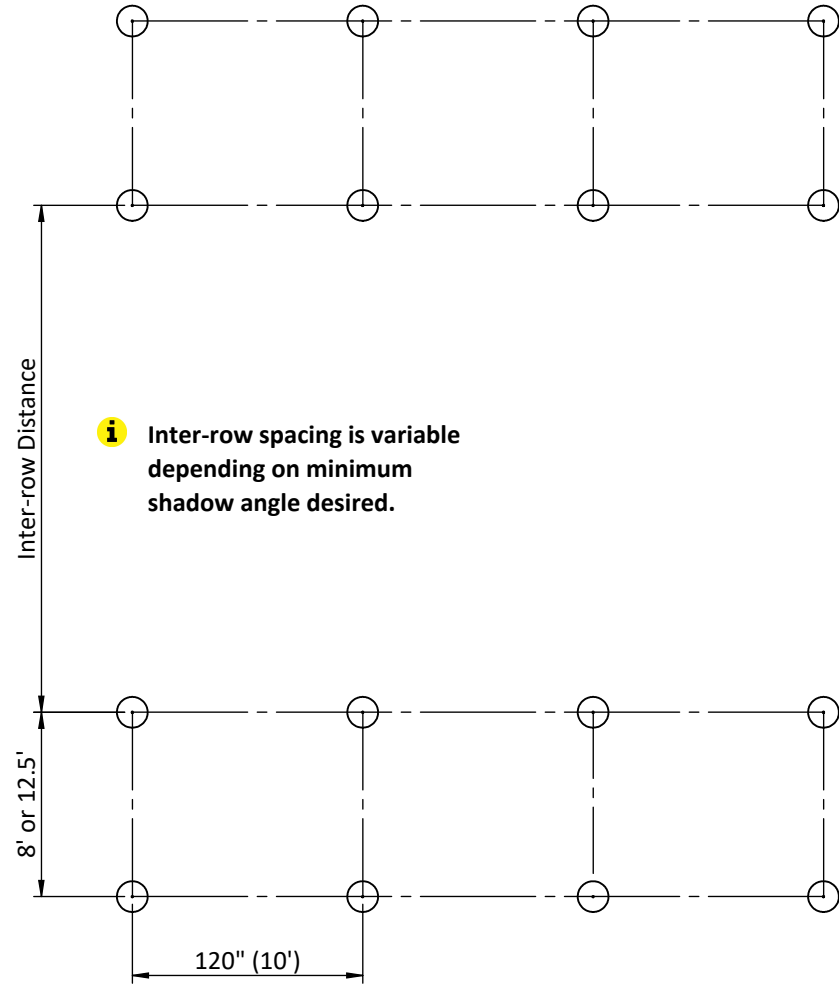

**i** 10' spans between legs

Foot Spacing Tolerances	
East-West	± 1"
North-South	± 1"
Height	± 0.5"

**!** Take care to install bases accurately. Feet should be installed within the listed tolerances to maintain system alignment.



### 4.2 Angle Selection

1. The FR-Elite can be installed at a tilt angle of 35° or 45°.
2. The foundations are to be spaced at the 12.5' or 8' marks in North-South direction depending on the selected tilt angle.
3. Use the following chart to properly space and position your system and to calculate appropriate inter-row spacing for the desired tilt angle.

ANGLE	POSITION	SPACING	HEIGHT
35	P1	12.5'	117"
45	P2	8'	136"

**i** Tilt angle must be selected before constructing the foundations.

**!** Tilt is NOT seasonally adjustable.

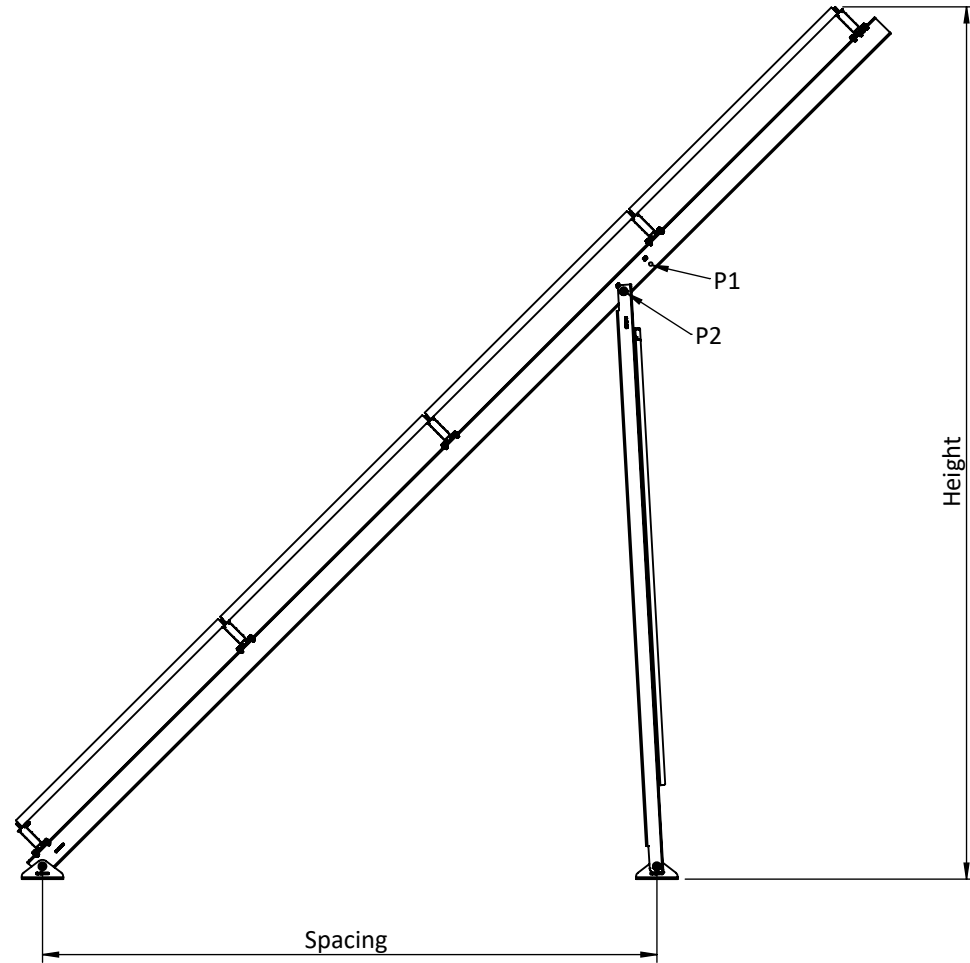



### 5.0 Preparing to Install the Frames

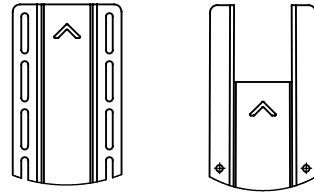
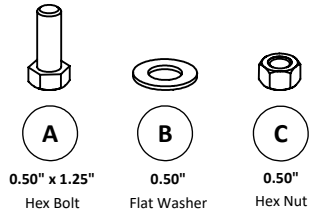

**i** The arrow markings identify the top end of the Front and Back Legs

1. Before installing the frames, ensure the Feet are secured and properly aligned.
2. All feet for the array should be installed on the foundations prior to beginning with the frame assembly.
3. Begin by bolting on the Back Leg and Front Leg to the Feet, leaving the hardware loosely installed.
4. Look for the arrow markings on the Legs. These identify the top end of each component.
5. Tilt up the legs and bolt together at the top connection point. Ensure the correct bolting position is selected.
6. Torque all hardware once all connections have been made.
7. Prepare to install the Cross Braces to support the Leg. Avoid leaving the legs standing unsupported.

**i** Connect to position:  
P1 for 35°  
P2 for 45°

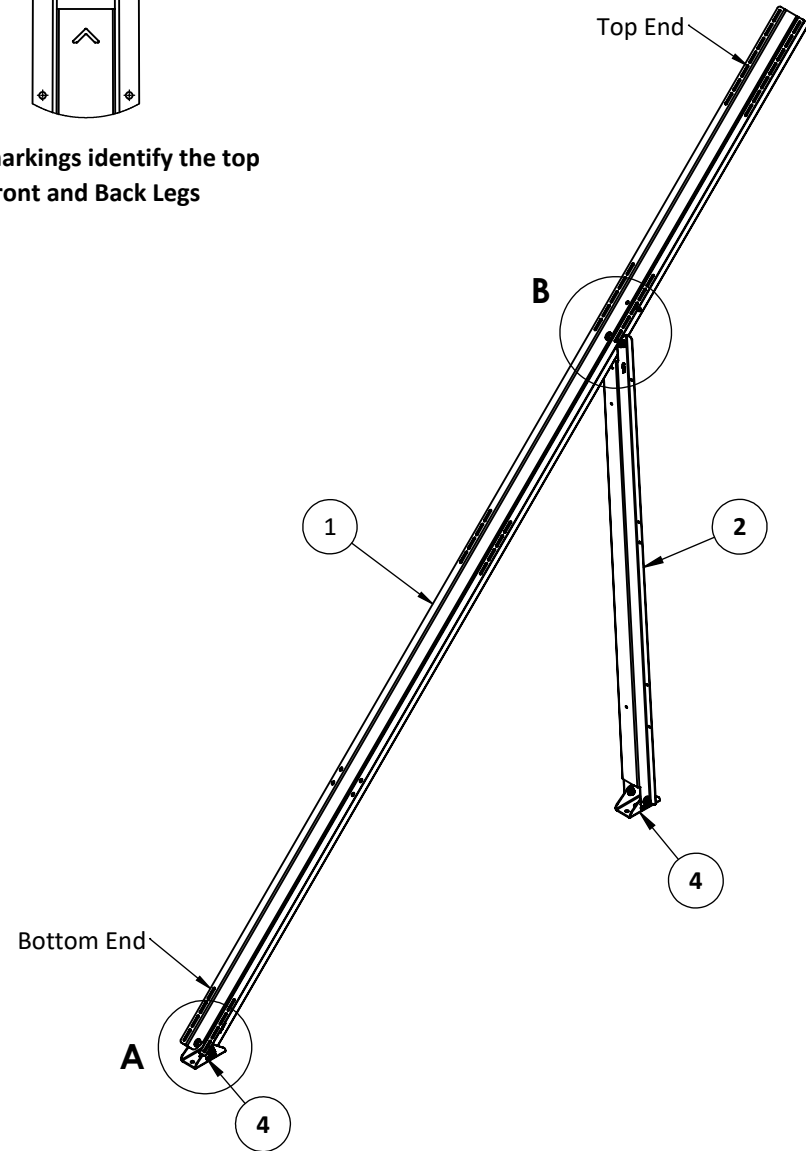
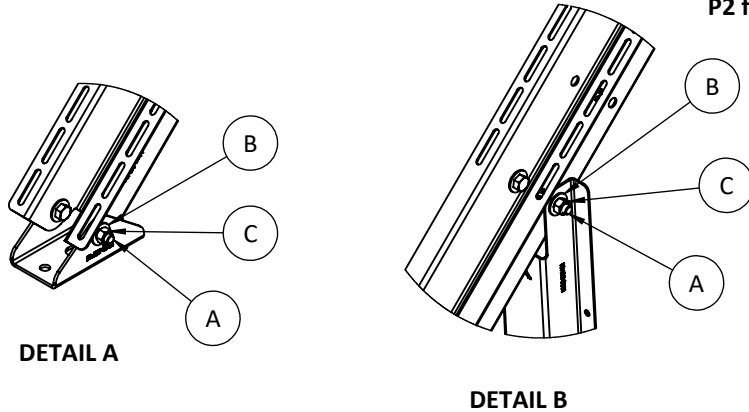



### 5.1 Installing the Cross Brace



D

M8 x 20mm  
Flanged Hex Bolt



E

M8  
Flanged Hex Nut

1. Attach the Cross Braces between the Back Legs by mounting to the outer flange of the Leg.
2. Install the end of the Cross Brace with the hole first.
3. Swing the Cross Brace until the slotted end aligns with the mounting hole on the adjacent Back Leg.
4. The Cross Brace should always start on the upper end of the outer Legs in an array.
5. Once the Cross Brace is installed, check the system for alignment before torquing.

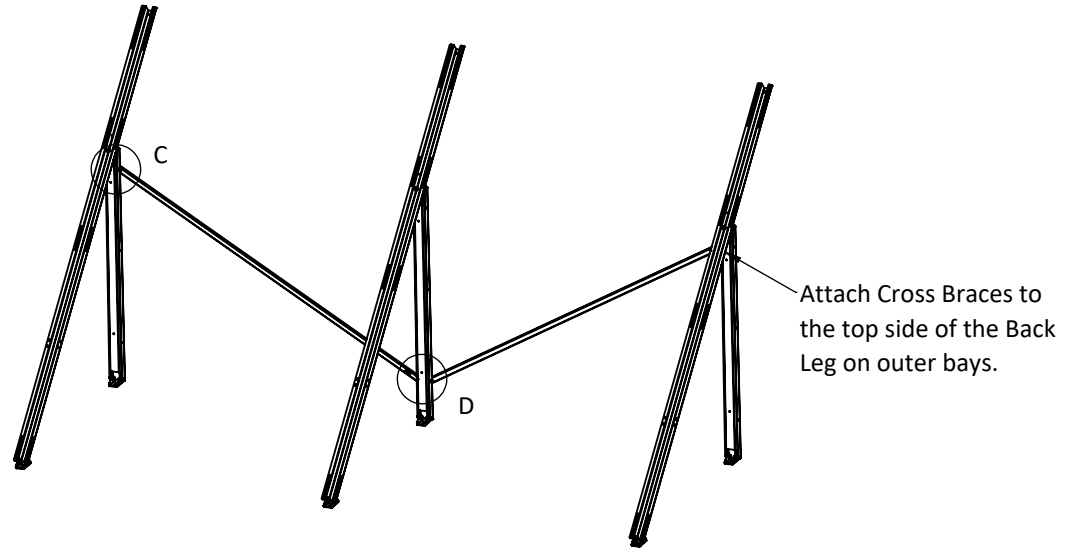

2-Leg **i** Two-legged systems will always have a dual cross brace.

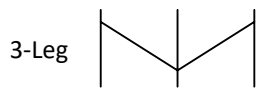

4-Leg **i** Center bay has no cross brace for even leg counts

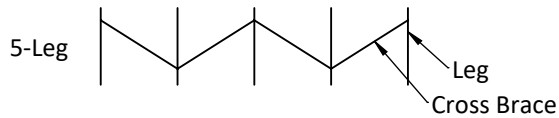

Cross Brace Configurations

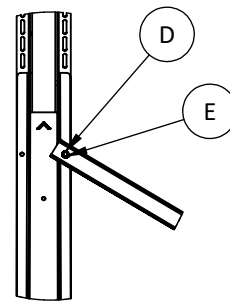

DETAIL C

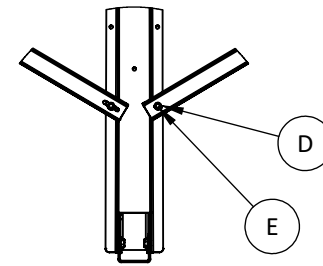

DETAIL D



## 5.2 Dual Cross Brace

1. Arrays with only 2 Legs should always have a dual Cross Brace.
2. The first Cross Brace mounts to the outer flanges of the Back Legs as per the steps outlined in section 5.1.
3. The second Cross Brace is installed on the inside of the Back Legs to avoid interference.
4. It will bolt to the holes centered on the middle web of the Back Leg.

**i** The two-legged configuration is the only time the dual Cross Brace is required.

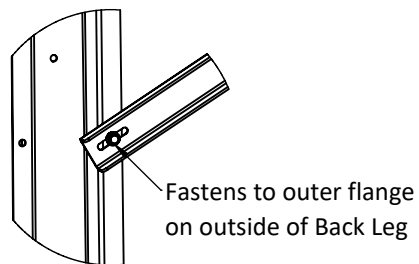
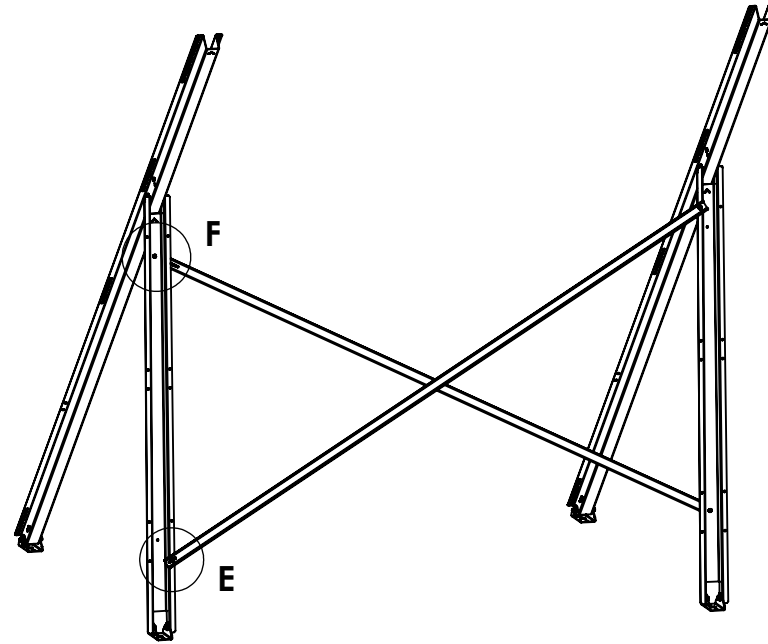

DETAIL E

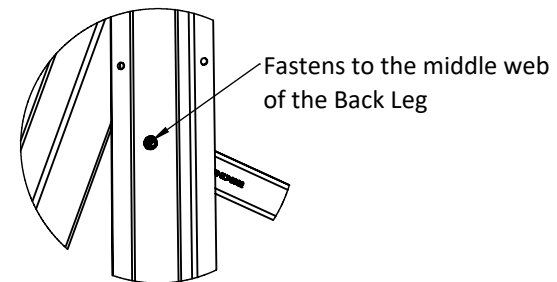

DETAIL F



## 6.0 Preparing to Install the Rails

1. Position the Rails on the Front Leg in line with the slotted connection points.
2. Measure the spacing between the rail flanges based on the width of the PV Modules.
3. Center the Rails over the frames so that the cantilever is even on both ends.
4. Fasten the first rail in the 'Starter Position'.
5. Measure adjacent rails from this point according to the width of the PV module. Using a jig can improve speed and accuracy of Rail spacing.

**i** 'Starter Position' is the set of holes on the Front Leg. (second rail from the bottom)

**i** Use a spacer jig to set rail spacing for module width

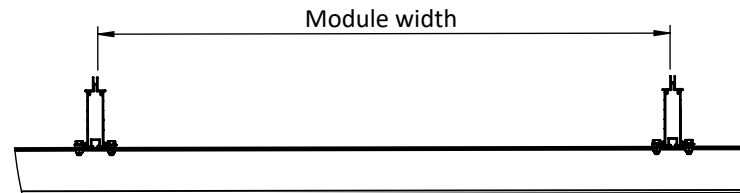
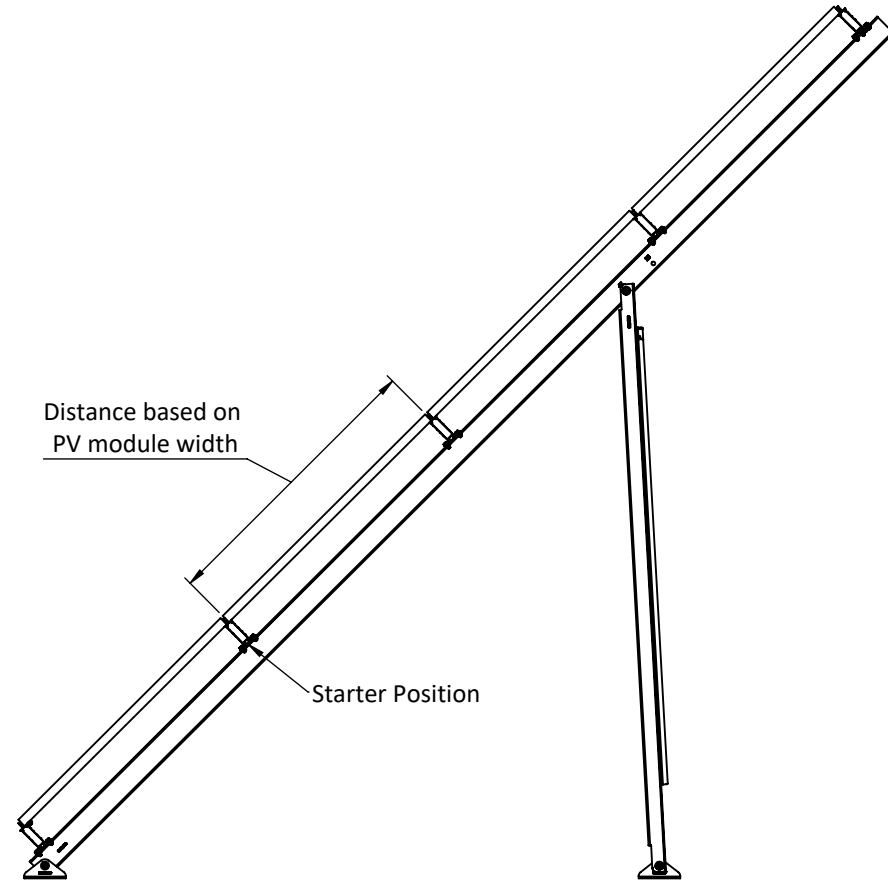



## 6.1 Rail Configurations

### 2-Leg Configuration

1. Two lengths of rail are used within the FR-Elite system depending on the length of the array.
2. The 2-Leg configuration used 120" rails, spliced at the mid span. Ensure rails are centered on the rack.
3. Install the Rail Splice as per section 6.2

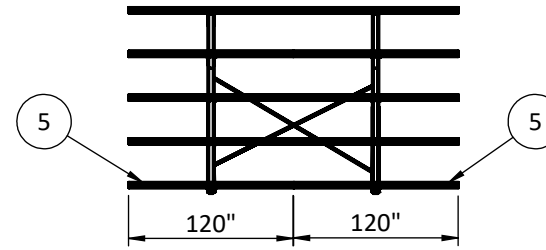

2-Leg Rails

**!** Rails meeting mid-span must be spliced.

### >2-Leg Configurations

1. For all other configurations, 170" rails are used on the outer bays, and 120" rails are used on the inner bays.
2. Rails should meet centered over the Front Leg. Rail splices are not required.

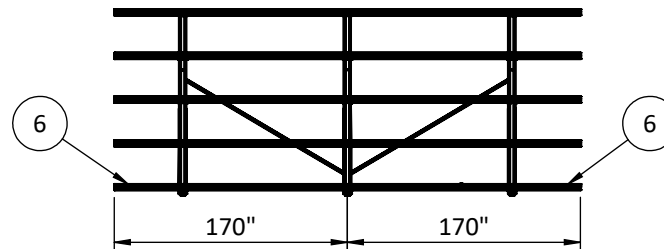

3-Leg Rails

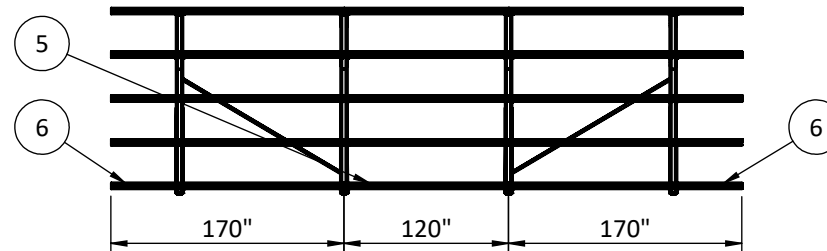

4-Leg Rails

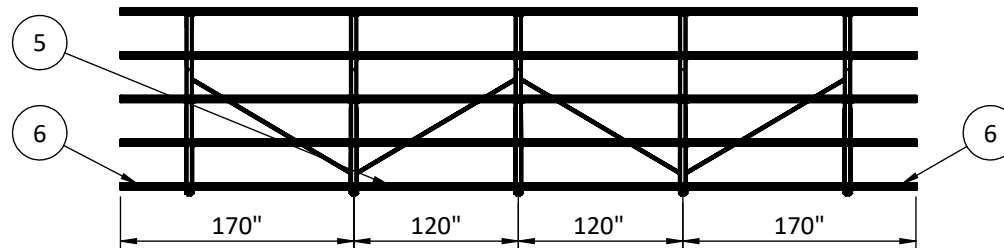

5-Leg Rails

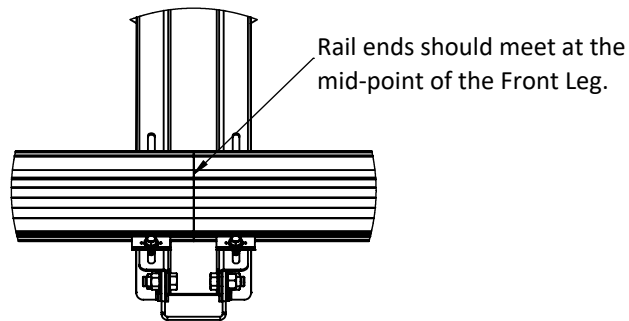



## 6.2 Installing the Rails



D

M8 x 20mm  
Flanged Hex Bolt



E

M8  
Flanged Hex Nut



F

Typhoon  
Clip C

1. Ensure the Rails are properly centered.
2. Roll the Typhoon Clip into the lower side channel of the Rail and position it over top of the bolting slots on the Front Leg.
3. Install four Clips per Rail to Leg connection.

**i** Ensure the Rail spacing fits the modules correctly before tightening connections.

**i** Typhoon clips to be installed on both sides of the rail.

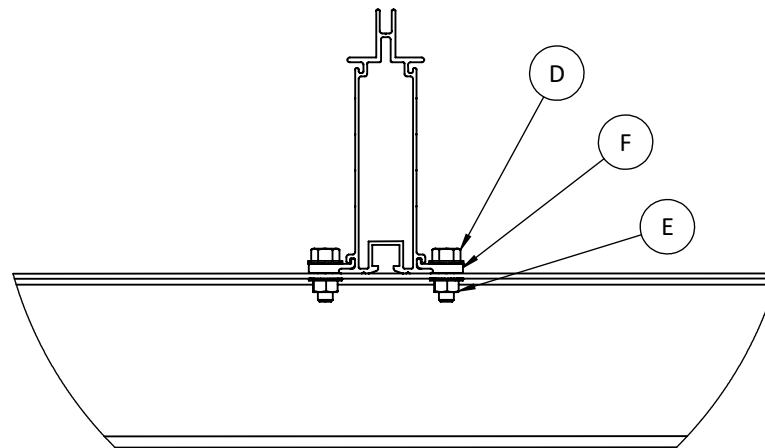
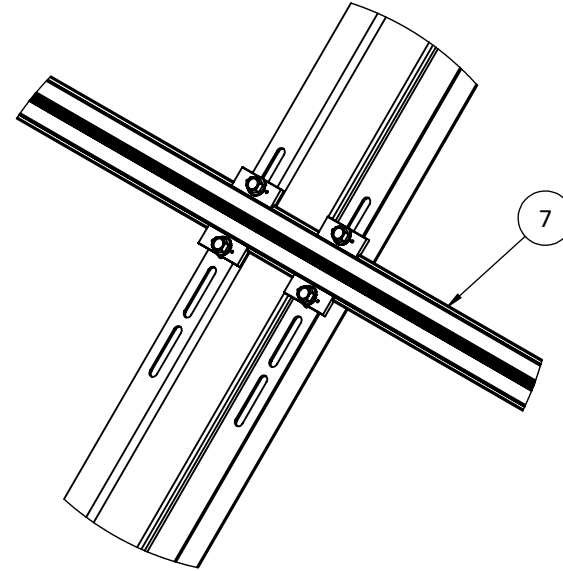



## 6.3 Installing the Rail Splice

1. Install a Rail splice at all mid-span rail connections
2. Keep sliding the splice until the rivet contacts the end of the Rail. This action will automatically center the Splice.
3. Once the Splice is in place, proceed to install the second Rail. Make sure it is pushed all the way in, engaging the bonding washer on the Splice.
4. After both Rails are properly installed, there should be a 1/4" gap between them.

**i** The Splice is only required for mid-span rail connections.

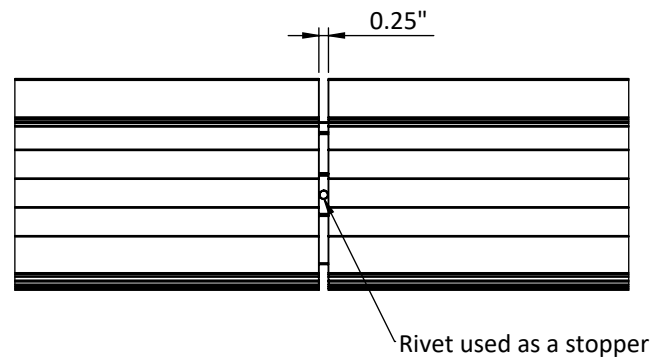
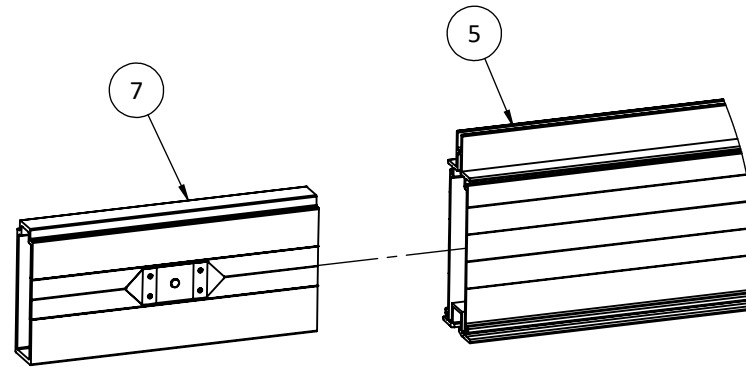



## 7.0 Preparing to Install the PV Modules

1. Prepare for installing the PV modules. Begin by spacing the Typhoon Rails.
2. Rails are to be spaced according to the width of the module.
3. Verify the spacing before torquing the Rail hardware. Ensure the spacing is even across the length of the Rails.
4. PV modules will rest on the flanges of the Typhoon Rails.
5. PV modules should be centered on the array.

**i** PV modules must be bolted at 4 points using the mounting holes provided in the module frame.

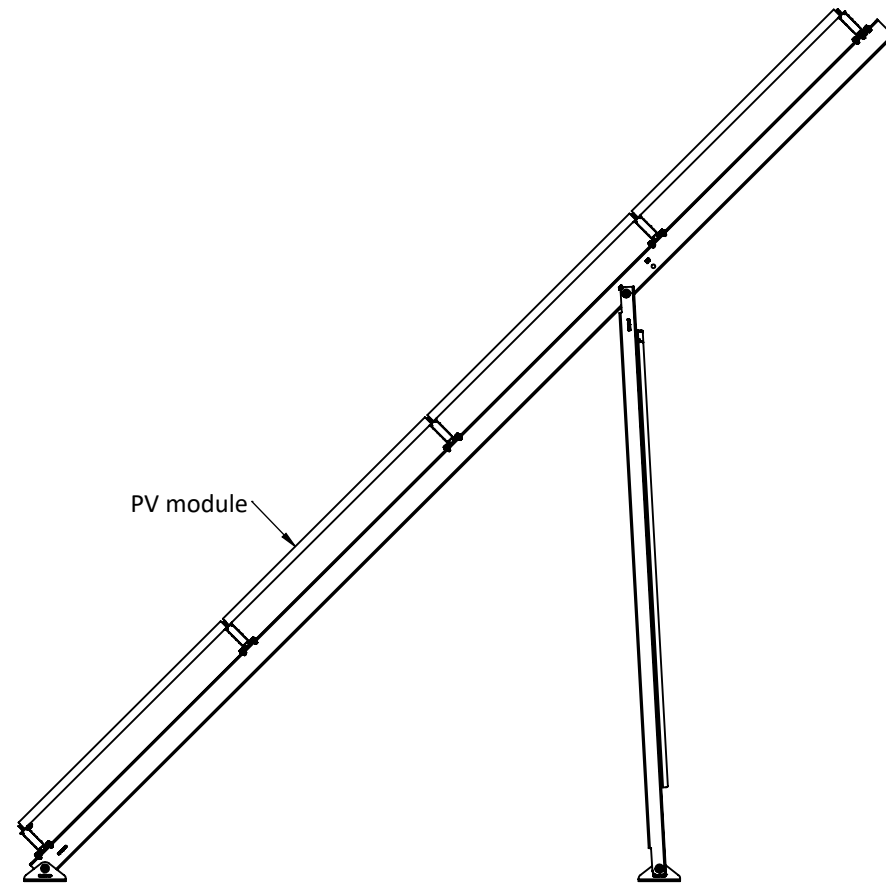



## 7.1 Installing the PV Modules



D

M8 x 20mm  
Flanged Hex Bolt



E

M8  
Flanged Hex Nut



F

Typhoon  
Clip C

1. PV-Modules rest on the top flanges of the Typhoon Rails.
2. The middle three rails will hold a PV-Module on each side and function as a shared rail.
3. Place all of the PV-Modules onto the rails and check their positioning. Leave min. 1/8" gap between modules.
4. The PV-Modules are bonded to the rails using disc bonding washers.
5. Each PV-module requires at least one bonding washer.
6. The bonding washer must be located in between the PV-Module frame and the rail flange.
7. Torque all hardware to ensure a proper bond.

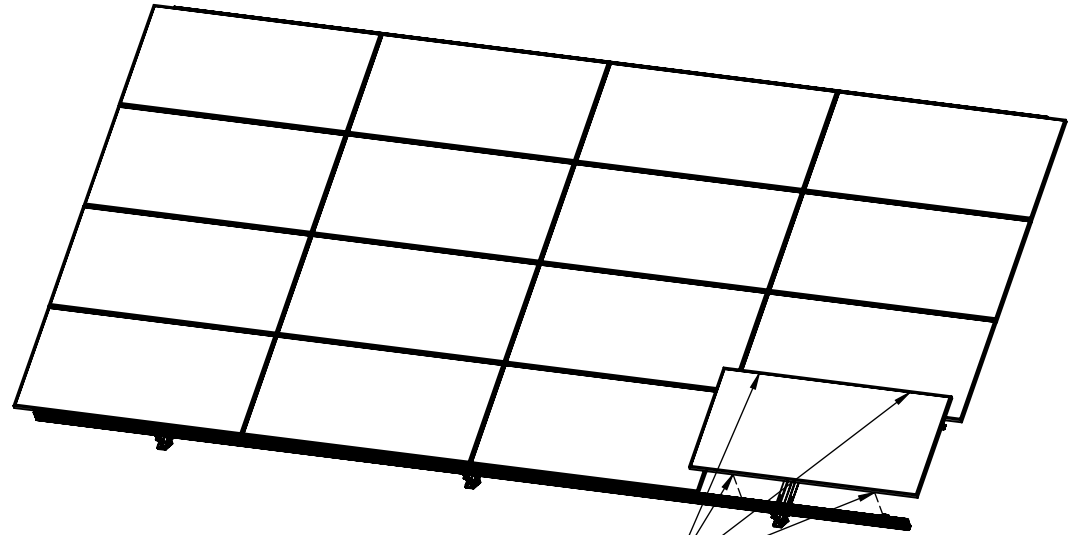

Modules bolted at 4-points

**i** Install one bond washer per PV module.

**i** Make sure to arrange the PV-modules so that they are centered along the length of the Rails.

**i** It is recommended to start at the middle of the array and work outwards.

**i** Refer to PV-Module installation manual for bolt-hole capacity limitations.

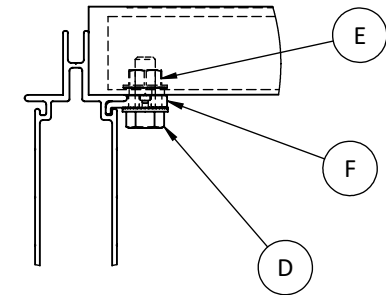
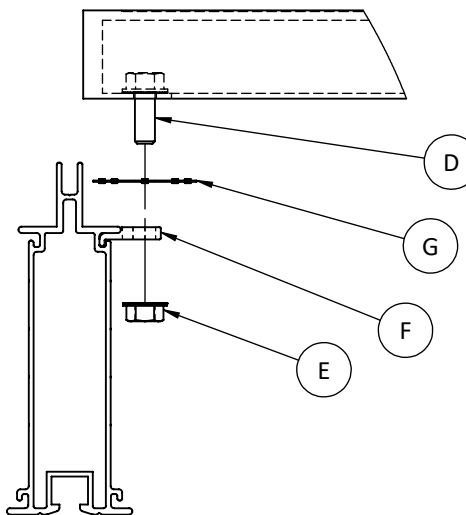



8

Bond Lug

1. The racking system features integrated bonding throughout. The bond washers establish a bond between the modules and the Rails.
2. When bond wire connections are required, install a bond lug on the racking system. It is advisable to install the bond lug on the bottom channel of the Rail as illustrated.

**i** Sub-arrays or additional equipment to be bonded with #6 Cu wire and bond lugs

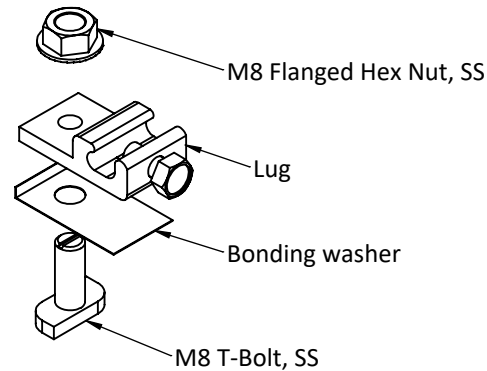
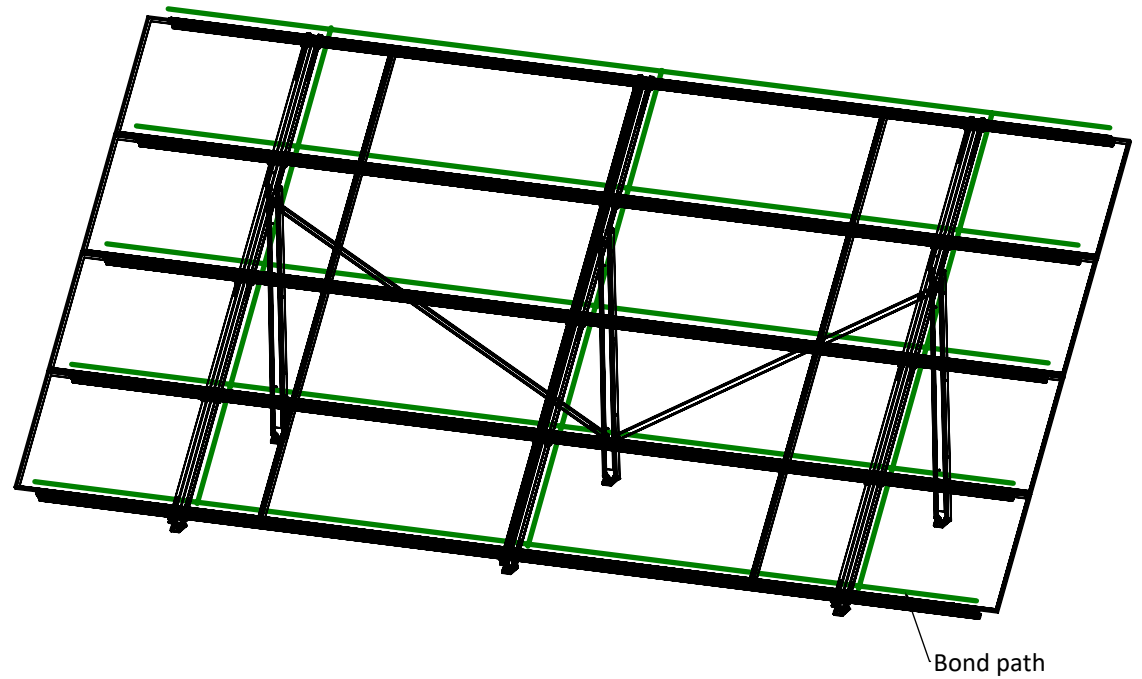

**Bond Lug**

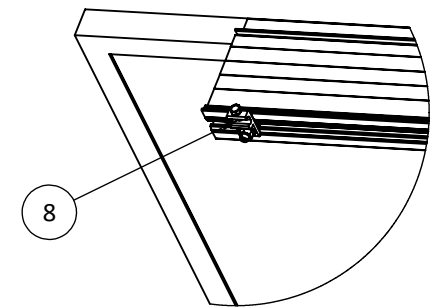



1. Ensure that PV wires are organized neatly underneath the modules, following the regulations outlined in local electrical codes.
2. To manage PV wires, you can use cable ties or clips to secure them to the Rails.

**⚠** It is the responsibility of the installer to ensure all wiring is installed in accordance with the applicable electrical codes.

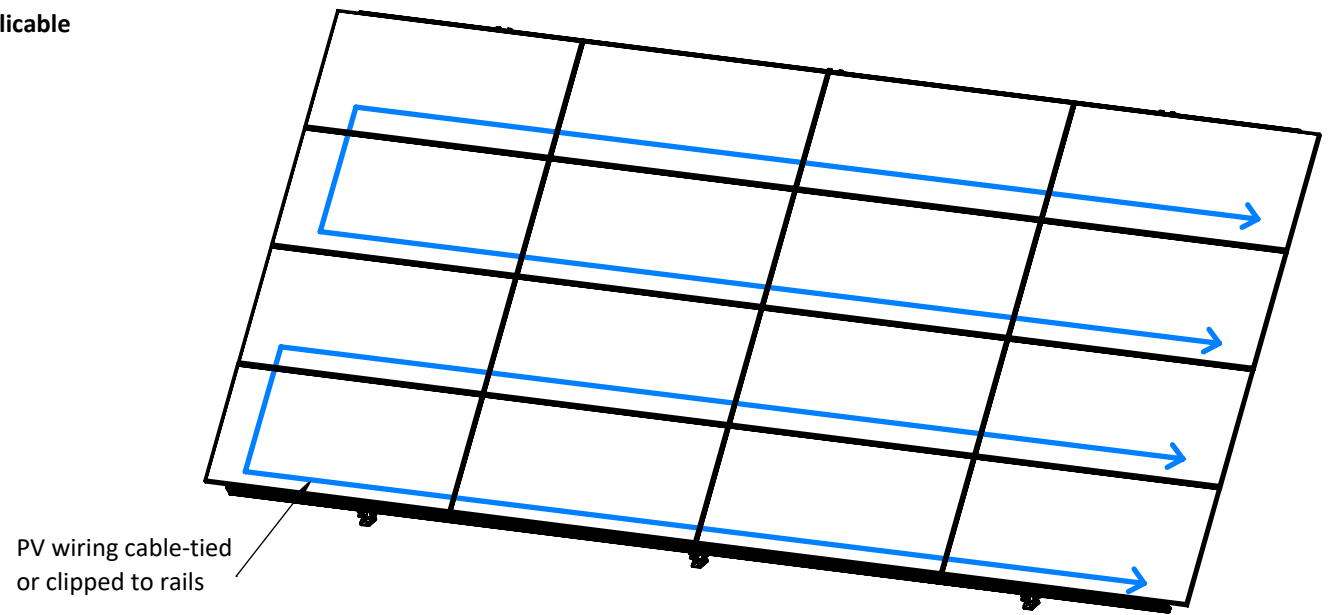



D

M8 x 20mm  
Flanged Hex Bolt



E

M8  
Flanged Hex Nut

1. The Inverter Mount fastens to the Back Leg with four M8 bolts.
2. An upper and lower mounting position are available depending on where the Cross Brace connects.
3. The Inverter Mount is a blank plate designed to fit most string inverters. Drill holes in the Inverter Mount as required to mount the inverter for your project.

**i** Mark and drill holes to mount the inverter according to the inverter installation manual.

**i** Inverter mount is 30"x30".

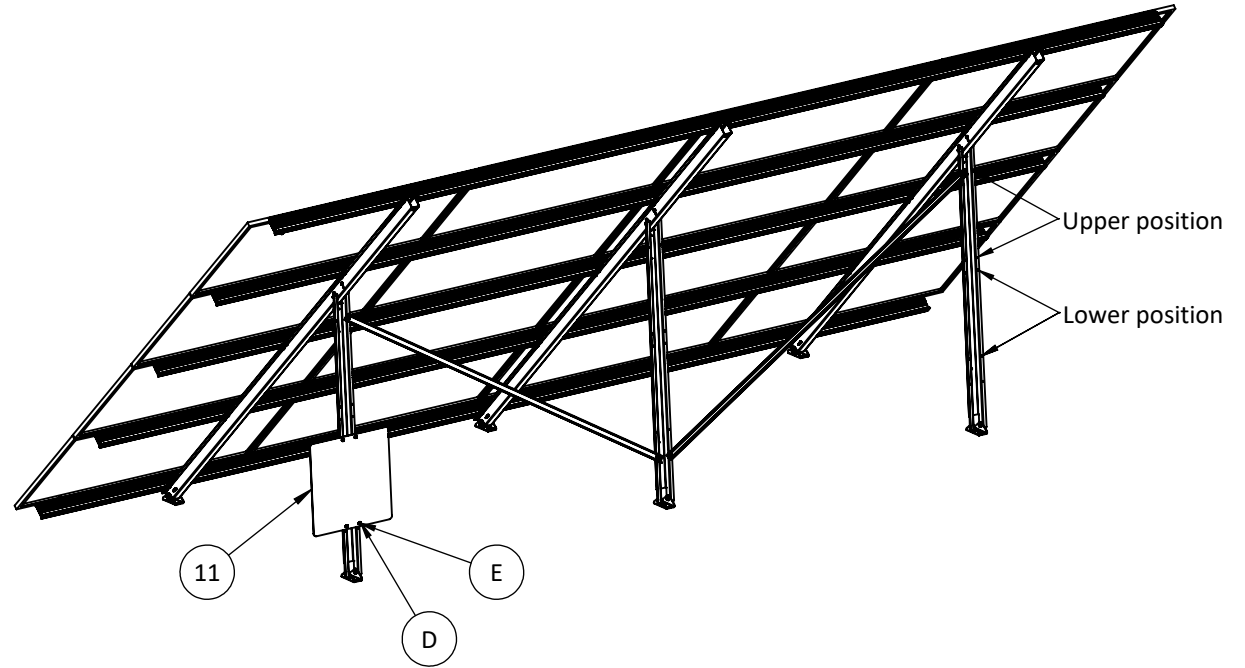



## 10.1 MLPE Mount

1. The MLPE mount is for installing module level electronics (microinverters, optimizers, etc.) to the Rails.
2. The MLPE mount fastens to the bottom surface of the rail and may be installed anywhere along its length.
3. Roll the Typhoon Clip into the side channel of the Rail.
4. Hook the metal bracket around the bottom of the rail and slide back until it is fully engaged.
5. Install the MLPE using the same bolt.
6. Once the MLPE is aligned, tighten and torque the hardware.

**i** Multiple brackets may be required for larger MLPE's. Refer to the MLPE installation instructions.

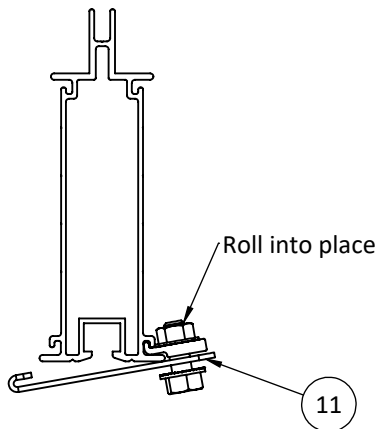
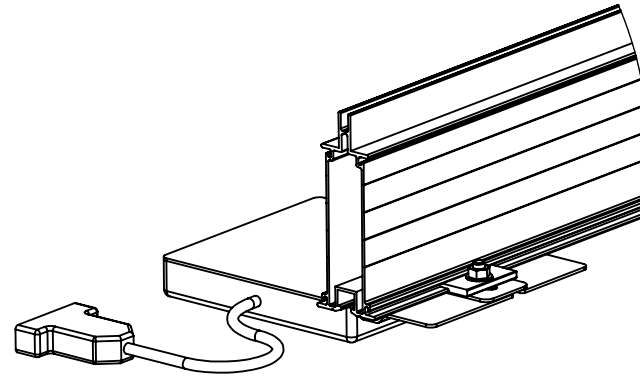

Step 1

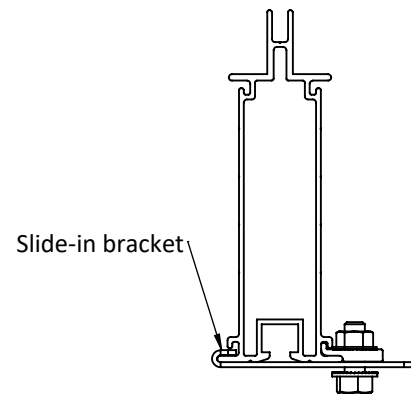

Step 2

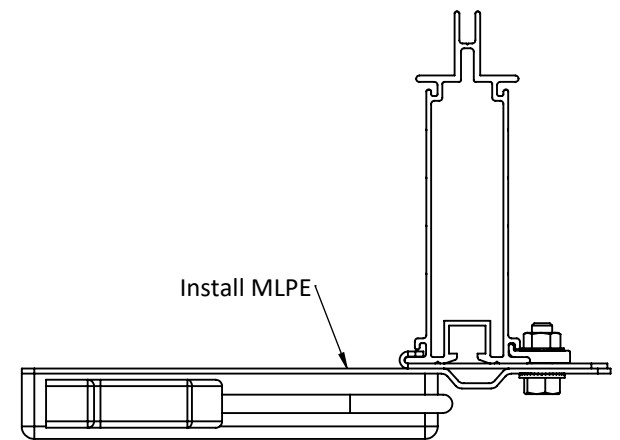

Step 3



## Introduction

The primary purpose of regular inspection and maintenance is to ensure the safe and efficient operation of your ground-mounted racking system. By following these guidelines, you can identify and address issues before they lead to performance degradation or safety concerns.

### Safety Precautions

Before conducting any inspection or maintenance activities, adhere to the following safety precautions:

- **Safety Gear:** Wear appropriate personal protective equipment (PPE), including safety glasses, gloves, and a hard hat.
- **Secure Access:** Ensure you have safe and secure access to the solar racking system. Use ladders or scaffolding when necessary, and be aware of potential fall hazards.
- **Electrical Safety:** If inspecting electrical components, follow electrical safety procedures. Always de-energize and lockout/tagout electrical systems before inspection.
- **Teamwork:** Whenever possible, work with a partner who can assist with safety measures and procedures.

## Corrosion Prevention

### Inspecting Steel Components

Steel components are susceptible to rust, so it's crucial to monitor them:

- Regularly inspect steel components for any signs of excessive rust, including flaking or discoloration.
- Pay close attention to areas where galvanized finish may have chipped or scratched, as these areas are more vulnerable to corrosion.

### Rust Treatment

Rust along the cut edges of steel components is normal and acceptable. If you notice excessive rust on steel components, take appropriate action:

- Remove loose rust and corrosion using a wire brush or sandpaper.
- Apply an appropriate rust inhibitor or primer to prevent further corrosion.
- Spray the affected area with a cold galvanizing compound to maintain protection.

## Regular Inspection

### Visual Inspection

Perform visual inspections on a regular basis to identify any visible issues:

- Check for loose or missing bolts, nuts, or fasteners.
- Inspect for signs of corrosion or rust on steel components.
- Examine the overall condition of the racking structure for any damage.
- Ensure that the solar panels are securely fastened and not damaged.

### Torque Check

Regularly check the torque of bolts and nuts to maintain the structural integrity of the system:

- Use a torque wrench to verify that all fasteners are tightened to the manufacturer's specifications.

### Electrical Inspection

Inspect electrical components to ensure safe and efficient operation:

- Examine electrical connections for signs of wear, corrosion, or loose wires.
- Check the condition of junction boxes, wiring, and connectors.
- Monitor the performance of inverters and other electrical equipment as per the manufacturer's recommendations.

### Structural Integrity

Ensure the structural integrity of the racking system:

- Check for any signs of settling or shifting of ballast blocks or anchors.
- Inspect for any signs of stress or damage to the mounting rails and supports.

## Frequency

Regular inspection intervals are essential to maintain the reliability of your solar racking system. Consider the following recommended inspection frequencies:

- **Quarterly:** Electrical inspections, structural integrity checks, and a comprehensive visual inspection should be conducted every three months.
- **Annually:** A more thorough inspection, including rust prevention measures, should be performed at least once a year.

However, it's essential to adapt the inspection frequency to your specific environmental conditions. If your system is exposed to harsh weather or other challenging factors, more frequent inspections may be necessary.



The max allowable wind and snow pressure is dependant on the tilt of the array and the chord width of the module. The following chart lists the maximum pressures for each configuration for module widths of up to 1134mm. Contact Fast-Rack if your project design pressure exceeds the maximum allowable for the module you are using.

**Design Load Limitations**

	Downward Load	Upward Load
35° Tilt	2.33 kPa (48.7 psf)	1.61 kPa (33.6 psf)
45° Tilt	2.18 kPa (45.5 psf)	2.03 kPa (42.4 psf)

The values represent maximum combined wind, snow, and dead loads factored as per the NBCC 2020 or relevant provincial edition.

